

Supplementary Components



7/2

Product overview

7/4

Isolating power supplies and Output isolators

7/7

SITRANS I100

SITRANS I200

7/10

Displays

7/12

SITRANS RD100

SITRANS RD200

7/16

Remote data manager

SITRANS RD500

7/22

WirelessHART products

7/28

SITRANS AW200 - WirelessHART adapter

7/32

SITRANS AW210 - WirelessHART adapter





IE/WSN-PA LINK



You can download all instructions, catalogs and certificates for Supplementary Components free of charge at www.siemens.com/processinstrumentation

Supplementary Components

Product overview

Overview

	Application	Description	Catalog page	Programming Software
Isolating power supplies and Output isolators				
	Isolating power supply for supplying 2- and 3-wire transmitters and for connecting mA sources in the hazardous area	SITRANS I100 Isolating power supply with HART for rail mounting, with intrinsically-safe input.	7/4	-
	Output isolator for controlling valve positioners, i/p converters or indicators in the hazardous area	SITRANS I200 Output isolator with HART for rail mounting, with intrinsically-safe output	7/7	-
Displays				
	2-wire loop powered, NEMA 4X enclosed remote digital display for process instrumentation and for hazardous locations	SITRANS RD100 <ul style="list-style-type: none"> Versatile loop-powered meter that displays process variables in level, flow, pressure, temperature and weighing applications FM and CSA approved device that can be installed in a range of environments, including hazardous areas Large, easy-to-read display Easy to install and set up using quick two-step process 	7/10	-
	Universal input, panel mount remote digital display for process instrumentation. Supports RTD, TC, current and voltage inputs, and supporting software allows for remote configuration and data logging	SITRANS RD200 <ul style="list-style-type: none"> Universal remote display that accepts various inputs, making it an ideal fit for use with most field instruments Standard panel mount display with optional enclosures Two optional relays for alarm indication or process control applications Meter Copy feature to reduce setup time, cost and errors RD Software supporting remote configuration, monitoring and logging for up to 100 displays 	7/12	-
Remote data manager				
	Remote data monitoring providing integrated web access, alarm event handling, and data capture for instrumentation	SITRANS RD500 <ul style="list-style-type: none"> Supports up to 128 devices with the flexible I/O modules and Modbus serial devices, including field instruments Out-of-the-box operation, no software required, works with standard web browser Support Ethernet, cellular and PSTN communication Data and alarming through FTP, Email, SMS; HTML and Modbus TPC Up to 2 GB of data logging memory 	7/16	-

	Application	Description	Catalog page	Programming Software
WirelessHART products				
	WirelessHART adapter to enable standard 4 ... 20 mA or HART devices to wireless communication	SITRANS AW200 - WirelessHART adapter <ul style="list-style-type: none"> • Makes isolated information in HART field instruments airborne • Permits predictive instead of preventive maintenance strategies • Enables 4 ... 20 mA or HART devices to wireless communication • Up to 4 HART devices can be connected • Power up one connected field instrument 	7/22	SIMATIC PDM <ul style="list-style-type: none"> • Local with HART modem • Wireless via WirelessHART
	Explosion protected WirelessHART adapter to enable standard 4 ... 20 mA or HART devices to wireless communication	SITRANS AW210 - WirelessHART adapter <ul style="list-style-type: none"> • Wireless transfer of the process variable of a 4 to 20 mA device via direct connection • Wireless communication with up to 8 HART field devices in multidrop mode • Suitable for use in explosion-protected areas • Loop-powered or external power supply • Supports burst mode and event notification for adapters and connected devices 	7/28	SIMATIC PDM <ul style="list-style-type: none"> • Local with HART modem • Wireless via WirelessHART
	Gateway for the connection of WirelessHART field devices (HART V7.1) to Industrial Ethernet.	IE/WSN-PA LINK <ul style="list-style-type: none"> • Connection of up to 100 WirelessHART devices • Approved for operation in hazardous areas in Zone 2 • Open TCP/IP communication and Modbus TCP via the Ethernet interface • Can be used with HART-OPC servers of the HART Communication Foundation 	7/32	-

Supplementary Components

Isolating power supplies and Output isolators

SITRANS I100

Overview



Analog input 0/4 to 20 mA

The isolating power supplies are used for the intrinsically safe operation of 2- and 3-wire transmitters and for connecting to intrinsically safe mA sources.

The 2- and 3-wire transmitters are supplied with auxiliary power from the transmitter supply unit.

For 2-wire transmitters the isolators transfer the HART communication signal bidirectionally.

Benefits

- Active output 0/4 to 20 mA
- Suitable for 2-, 3-wire transmitters, 2-wire HART transmitters and mA sources
- Intrinsically safe input [Ex ia] IIC
- Galvanic isolation between input, output and auxiliary power
- Open-circuit and short-circuit monitoring and messaging for input and output (can be switched off)
- Installation possible in Zone 2 and Div. 2
- Can be used up to SIL 2 (IEC 61508)

	Zones					
	0	1	2	20	21	22
Ex i interfaces	X	X	X	X	X	X
Installation in			X			X

Design

The HART isolating power supply is comprised of a compact plastic enclosure (IP30) and is equipped with push-in screw terminals.

On the front are a green LED for indicating the power supply status and a red LED for signaling errors.

The auxiliary power supply can be connected individually using push-in screw terminals or jointly for up to 40 units using pac-Bus.

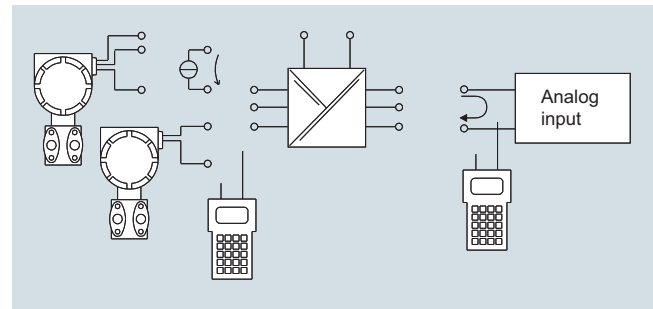

SITRANS I100 isolating power supply, function block diagram

Technical specifications

SITRANS I100 Isolating Power Supplies with HART

Ex i input

Input signal	0/4 ... 20 mA with HART
Functional range	0 ... 24 mA
Max. input current for mA sources	50 mA
Transmitter supply voltage	≥ 16 V at 20 mA (for 2-, 3-wire)
Supply voltage residual ripple	≤ 25 mV _{eff}
No-load voltage	≤ 26 V
Short-circuit current	≤ 35 mA
Input resistance (AC impedance HART)	≈ 500 Ω
Input resistance for mA sources	30 Ω
Communication signal (on 2-wire transmitters)	Bidirectional HART transmission, 0,5 ... 30 kHz

Output

Output signal	0/4 ... 20 mA with HART
Load resistance R _L	0 ... 600 W (terminal 1+/2-) 0 ... 379 W (terminal 3+/2-) (with internal 221 W resistance for HART)
Residual ripple	≤ 40 μA _{eff}
No-load voltage	≤ 15,5 V
Communication signal	Bidirectional HART transmission, 0,5 kHz ... 30 kHz
Response time (10 % ... 90 %)	≤ 25 ms
Transfer behavior	1:1
Input/Output	(0 ... 20 mA --> 0 ... 20 mA, 4 ... 20 mA --> 4 ... 20 mA)

Measuring accuracy

Accuracy, typical data expressed as % of calibrated span at U _N , 23 °C	
Linearity error	≤ 0,1 %
Offset error	≤ 0,1 %
Temperature influence	≤ 0,1 %/10 K
Power supply effect within voltage range	≤ 0,01 %
Load resistance effect	≤ 0,02 %

Supplementary Components

Isolating power supplies and Output isolators

SITRANS I100

Rated conditions		Error detection Ex i input	
Degree of protection of enclosure	IP30	• Open circuit	< 2 mA
Degree of protection of terminals	IP20	• Short-circuit	> 22 mA
Ambient conditions		• Output behavior	= Input signal
• Ambient temperature	-20 ... +60 °C/+70 °C (-4 ... +140 °F/+158 °F) (see "Operating instructions")	• Output current at $I_{in} = 0$	$I_{out} = 0$ mA
• Storage temperature	-40 ... +80 °C (-40 ... +176 °F)	Error detection output	
• Relative humidity (no condensation)	≤ 95 %	• Open circuit	< 2 mA
Electromagnetic compatibility	Tested under the following standards and regulations: EN 61326-1 Use in the industrial environment	Error messaging Ex i input/output	
Mechanical specifications		• Settings (LF switch)	Activated/deactivated
Screw terminals		• Error indication	LED red "LF"
• One-wire connexion		Error messaging and power supply failure	• Contact (30 V/100 mA), closed to ground in case of error
- Rigid	0,2 ... 2,5 mm ² (0.00031 ... 0.0039 in ²)	• pac-Bus, floating contact (30 V/100 mA)	
- Flexible	0,2 ... 2,5 mm ² (0.00031 ... 0.0039 in ²)	Certificates and approvals	
- Flexible with end ferrules (without/with plastic ferrule)	0,25 ... 2,5 mm ² (0.00039 ... 0.0039 in ²)	Explosion protection ATEX	
• Two-wire connection		• EC type-examination certificate	DMT 03 ATEX E 010 X
- Rigid	0,2 ... 1 mm ² (0.00031 ... 0.00155 in ²)	• Degree of protection	II 3 (1) G Ex nA nC [ia] IIC T4 II (1) D [Ex iaD]
- Flexible	0,2 ... 1,5 mm ² (0.00031 ... 0.0023 in ²)	Installation	In Zone 2, Div. 2 and in the safe area
- Flexible with end ferrules	0,25 ... 1 mm ² (0.00039 ... 0.00155 in ²)	Other approvals	USA (FM) Kanada (CSA) Shipping (DNV)
Weight	Approx. 160 g (0.35 lb)	Safety specifications (CENELEC)	
Type of installation	On DIN rail according to EN 50022 (NS35/15; NS35/7.5)	• Max. voltage U_o	27 V
Mounting position	Vertical or horizontal	• Max. current I_o	88 mA
Enclosure material	PA 6.6	• Max. power P_o	576 mW
Fire protecting class (UL-94)	V0	• Max. connectable capacitance C_o for IIC/IIB	90 nF/705 nF
Auxiliary power		• Max. connectable inductance L_o for IIC/IIB	2,3 mH/14 mH
Rated voltage U_N	24 V DC	• Internal capacitance C_i and inductance L_i	Negligible
Voltage range	18 ... 31,2 V	• Insulation voltage U_m	253 V
Residual ripple within voltage range	≤ 3,6 V_{SS}	• When connecting mA sources:	
Rated current (U_N , 20 mA)	70 mA	- Max. output voltage U_o	4,1 V
Power consumption (U_N , 20 mA)	1,7 W	- Max. connectable voltage U_i	30 V
Power loss (at U_N , $R_L = 250 \Omega$)	1,3 W	- Max. connectable current I_i	100 mA
Operation indicator	Green "PWR" LED	- Internal capacitance C_i and inductance L_i	Negligible
Reverse polarity protection	Yes	• For more information and value combinations	See "Certification"
Undervoltage monitoring	Yes (no faulty module/output states)		
Galvanic isolation			
• Test voltage according to EN 60079-11			
- Ex i input to output	1,5 kV AC		
- Ex i input to auxiliary power	1,5 kV AC		
- Ex i input to Error contact	1,5 kV AC		
• Test voltage according to EN 50178			
- Output to auxiliary power	350 V AC		
- Error contact to auxiliary power and output	350 V AC		

Supplementary Components

Isolating power supplies and Output isolators

SITRANS I100

Selection and Ordering data	Article No.
SITRANS I100 Isolating Power Supply with HART For rail mounting, for supplying 2-/3-wire transmitters and for mA sources, output 0/4 ... 20 mA, with intrinsically safe input	7NG4124-0AA00
Accessories	
pac-Bus basic set With 5 single elements and 1 terminal set (beginning and end)	7NG4998-1AA
pac-Bus extension set With 5 single elements	7NG4998-1AB
▶ Available ex stock.	

Dimensional drawings

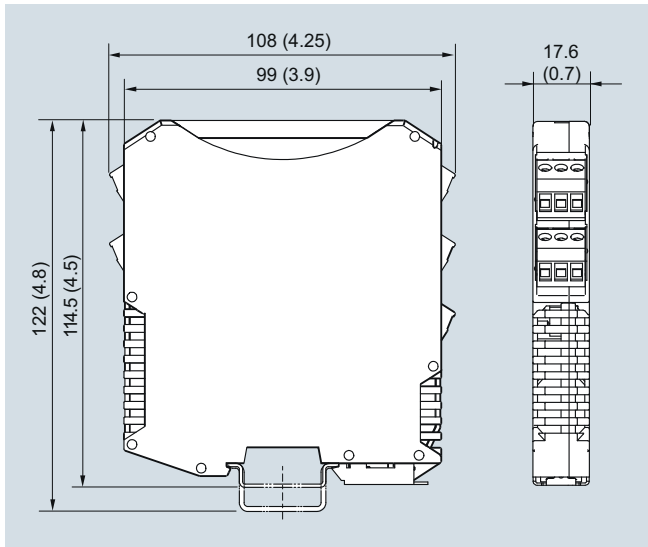

SITRANS I100 isolating power supply with HART, dimensions in mm (inch)

Schematics

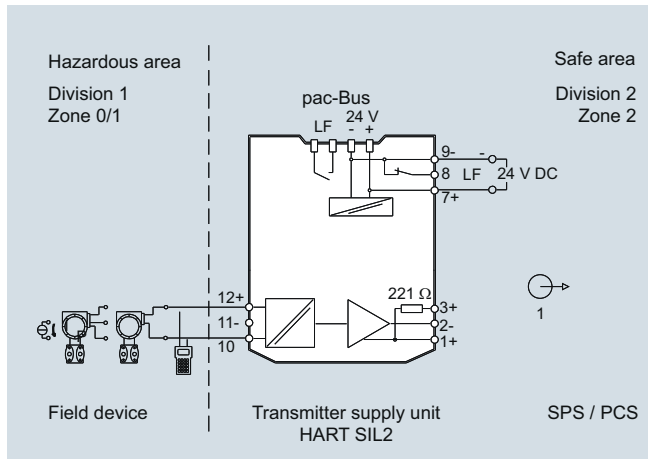

SITRANS I100 isolating power supply with HART, connection diagram

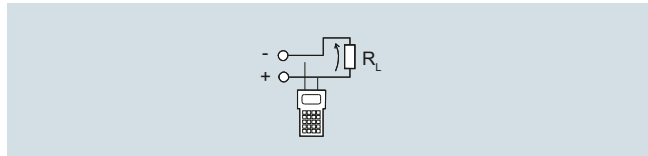

SITRANS I100 isolating power supply with HART, output configuration

Overview



Analog output 0/4 to 20 mA for HART

The output isolators are used for the intrinsically safe operation of valve positioners, i/p converters or indicators.

Operation of intrinsically safe HART valve positioners (e.g. SIPART PS2 and SITRANS VP300) is also possible. The units transfer a superimposed HART communication signal bidirectionally.

Benefits

- For HART output signals 0/4 to 20 mA
- Intrinsically safe output [Ex ia] IIC
- Galvanic isolation between input, output and auxiliary power
- Open-circuit and short-circuit monitoring and messaging (can be switched off)
- Installation possible in Zone 2 and Div. 2
- Can be used up to SIL 2 (IEC 61508)

	Zones					
	0	1	2	20	21	22
Ex i interface	X	X	X	X	X	X
Installation in			X			X

Design

The HART output isolator is comprised of a compact plastic housing (IP30) and is equipped with push-in screw terminals.

On the front are a green LED for indicating the power supply status and a red LED for signaling errors.

The auxiliary power supply can be connected individually using push-in screw terminals or jointly for up to 40 units using pac-Bus.

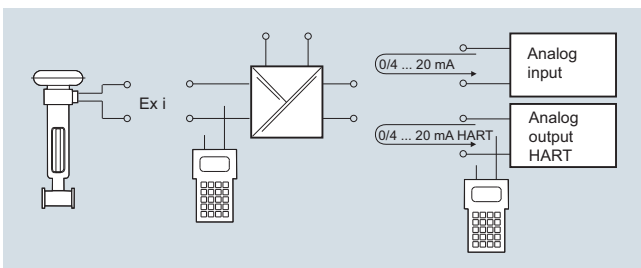

SITRANS I200 output isolator, function block diagram

Technical specifications

SITRANS I200 output isolator with HART

Input

Input signal	0/4 ... 20 mA with HART
Functional range	0 ... 24 mA
Max. input current	50 mA
Input resistance (changeable switch LI)	225 Ω/550 Ω
Communication signal	Bidirectional HART transmission, 0.5 ... 30 kHz

Ex i output

Output signal	0/4 ... 20 mA with HART
Connectable load resistance	0 ... 800 Ω
Min. load resistance for short-circuit monitoring	150 Ω
Residual ripple	≤ 50 mV
No-load voltage	≤ 25,6 V
Response time (10 % ... 90 %)	≤ 25 ms
Transfer behavior Input/Output	1:1 (0 ... 20 mA --> 0 ... 20 mA, 4 ... 20 mA --> 4 ... 20 mA)

Measuring accuracy

Accuracy, typical data expressed as % of calibrated span at U_N , 23 °C

Linearity error	≤ 0,1 %
Offset error	≤ 0,1 %
Temperature influence	≤ 0,1 %/10 K
Power supply effect within voltage range	≤ 0,01 %
Load resistance effect	≤ 0,02 %

Rated conditions

Degree of protection of enclosure	IP30
Degree of protection of terminals	IP20
Ambient conditions	
• Ambient temperature	-20 ... +70 °C (-4 ... +158 °F) (see "Operating instructions")
• Storage temperature	-40 ... +80 °C (-40 ... +176 °F)
• Relative humidity (no condensation)	≤ 95 %
Electromagnetic compatibility	Tested under the following standards and regulations: EN 61326-1 Use in the industrial environment

Supplementary Components

Isolating power supplies and Output isolators

SITRANS I200

Mechanical specification

Screw terminals

- One-wire connection

- Rigid	0,2 ... 2,5 mm ² (0.00031 ... 0.0039 in ²)
- Flexible	0,2 ... 2,5 mm ² (0.00031 ... 0.0039 in ²)
- Flexible with end ferrules (without/with plastic ferrule)	0,25 ... 2,5 mm ² (0.00039 ... 0.0039 in ²)

- Two-wire connection

- Rigid	0,2 ... 1 mm ² (0.00031 ... 0.00155 in ²)
- Flexible	0,2 ... 1,5 mm ² (0.00031 ... 0.0023 in ²)
- Flexible with end ferrules	0,25 ... 1 mm ² (0.00039 ... 0.00155 in ²)

Weight

Approx. 160 g (0.35 lb)

Type of installation

On DIN rail according to
EN 50022 (NS35/15; NS35/7.5)

Mounting position

Vertical or horizontal

Enclosure material

PA 6.6

Fire protecting class (UL-94)

V0

Auxiliary power

Rated voltage U_N

24 V DC

Voltage range

18 ... 31,2 V

Residual ripple within voltage
range $\leq 3,6 V_{SS}$ Rated current (U_N , 20 mA)

80 mA

Power consumption (U_N , 20 mA)

1,3 W

Power loss (at U_N , $R_L = 500 \Omega$)

1,1 W

Operation indicator

Green "PWR" LED

Reverse polarity protection

Yes

Undervoltage monitoring

Yes (no faulty module/output
states)

Galvanic isolation

- Test voltage according to
EN 60079-11

- Ex i output to input	1,5 kV AC
- Ex i output to auxiliary power	1,5 kV AC
- Error contact to Ex i output	1,5 kV AC

- Test voltage according to
EN 50178

- Input to auxiliary power	350 V AC
- Error contact to auxiliary power and input	350 V AC

Error detection Ex i output

• Open circuit	> 10 k Ω
• Short-circuit	< 15 Ω
• Input behavior	> 6 k Ω
• Open-circuit detection only for input current	$\geq 3,6$ mA
• Settings (LF switch)	Activated/deactivated
• Error indication	LED red "LF"
• Error messaging and power supply failure	<ul style="list-style-type: none"> Contact (30 V/100 mA), closed to ground in case of error pac-Bus, floating contact (30 V/100 mA)

Certificates and approvals

Explosion protection ATEX

- EC type-examination certificate

DMT 03 ATEX E 012 X

- Degree of protection

II 3 (1) G Ex nA nC [ia] IIC T4
II (1) D [Ex iaD]

Installation

In Zone 2, Div. 2 and in the safe
area

Other approvals

USA (FM)
Canada (CSA)
Shipping (DNV)

Safety specifications (CENELEC)

• Max. voltage U_o	25,6 V
• Max. current I_o	96 mA
• Max. power P_o	605 mW
• Max. connectable capacitance C_o for IIC/IIB	103 nF/800 nF
• Max. connectable inductance L_o for IIC/IIB	1,9 mH/11 mH
• Internal capacitance C_i and induc- tance L_i	Negligible
• Insulation voltage U_m	253 V
• For more information and value combinations see "Certification".	

Selection and Ordering data

Article No.

SITRANS I200 output isolator with HART

For rail mounting, input
0/4 ... 20 mA, output 0/4 ... 20 mA,
intrinsically safe▶ **7NG4131-0AA00**

Accessories

pac-Bus basic set

With 5 single elements and 1
terminal set (beginning and end)▶ **7NG4998-1AA**

pac-Bus extension set

With 5 single elements

▶ **7NG4998-1AB**

▶ Available ex stock.

Dimensional drawings

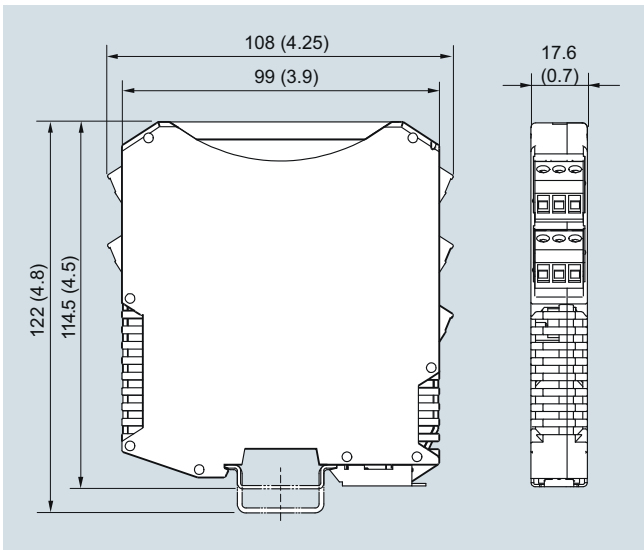

SITRANS I200 output isolator with HART, dimensions in mm (inch)

Schematics

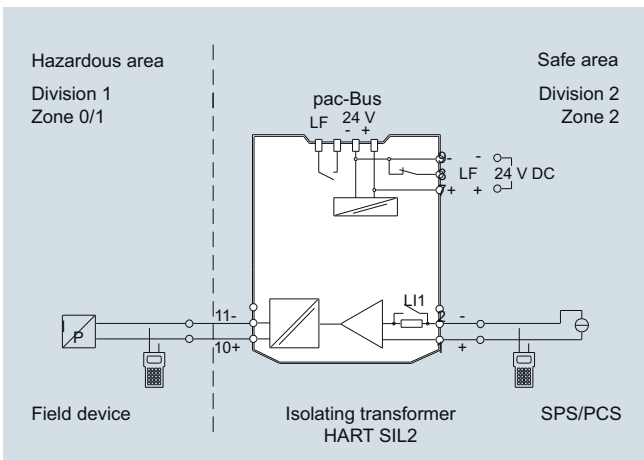

SITRANS I200 output isolator with HART, connection diagram

Supplementary Components

Displays

SITRANS RD100

Overview



The SITRANS RD100 is a 2-wire loop powered, NEMA 4X enclosed remote digital display for process instrumentation.

Benefits

- Easy setup
- Approved for hazardous locations
- NEMA 4X, IP67 impact-resistant enclosure
- Simple two-step calibration
- Two modes of input allow for easy servicing, with no interruption of loop required

Application

The RD100 is very versatile. It can be installed indoors or outdoors, in hot or cold environments, and in safe or hazardous areas.

It has been approved by FM and CSA as Intrinsically Safe and non-incendive, and operates from -40 to +85 °C (-40 to +185 °F), adding only 1 V to the loop.

The RD100 has a large 1 inch (2.54 cm) high display making it easy to read.

Calibration consists of a quick, two-step process involving the adjustment of only two non-interacting potentiometers.

- Key Applications: Remotely displays process variables in level, flow, pressure, temperature and weighing applications, in a 4 to 20 mA loop.

Technical specifications

Mode of operation	
Measuring principle	Analog to digital conversion
Measuring range	4 ... 20 mA
Measuring points	1 instrument only
Accuracy	± 0.1 % of span ± 1 count
Rated operating conditions	
Ambient conditions	
• Operating temperature range	-40 ... +85 °C (-40 ... +185 °F)
Design	
Weight	340 g (12 oz)
Material (enclosure)	Impact-resistant glass filled polycarbonate body and clear polycarbonate cover
Degree of protection	NEMA 4X, IP67

Power supply	30 V DC max.
Display	<ul style="list-style-type: none"> • 1 inch (2.54 cm) high LCD • Numeric range from -1 000 ... +1 999
Certificates and approvals	<p>Hazardous</p> <ul style="list-style-type: none"> • Intrinsically Safe • Non-incendive <p>CSA/FM Class I, II, III, Div. 1, Groups A, B, C, D, E, F, G T4</p> <p>CSA/FM Class I, Zone 0, Group IIC</p> <p>CSA/FM Class I, Div. 2, Groups A, B, C, D</p> <p>CSA/FM Class II and III, Div. 2, Groups F and G</p>
Options	<p>Mounting</p> <ul style="list-style-type: none"> • 2 inch (5.08 cm) pipe mounting kit (zinc plated or stainless steel) • Panel mounting kit

Selection and Ordering data	Article No.
SITRANS RD100 A 2-wire loop powered, NEMA 4X enclosed remote digital display for process instrumentation.	7ML5741- AA00-0
Conduit hole location (½ inch)	
None	▶ 1
Bottom	▶ 2
Rear	▶ 3
Top	▶ 4

▶ Available ex stock.

- We can offer shorter delivery times for configurations designated with the Quick Ship Symbol . For details see page 9/5 in the appendix.

Selection and Ordering data	Article No.
<i>Operating Instructions</i>	
English	7ML1998-5JU01
French	7ML1998-5JU11
German	7ML1998-5JU31
Note: The Operating Instructions should be ordered as a separate line item. This device is shipped with the Siemens Milltronics manual CD containing Quick Starts and Operating Instructions.	
<i>Accessories</i>	
Panel mount kit	7ML1930-1BN
2 inch (5.08 cm) pipe mounting kit (zinc plated seal)	7ML1930-1BP
2 inch (5.08 cm) pipe mounting kit (stainless steel, Type 304, EN 1.4301)	7ML1930-1BQ

Dimensional drawings

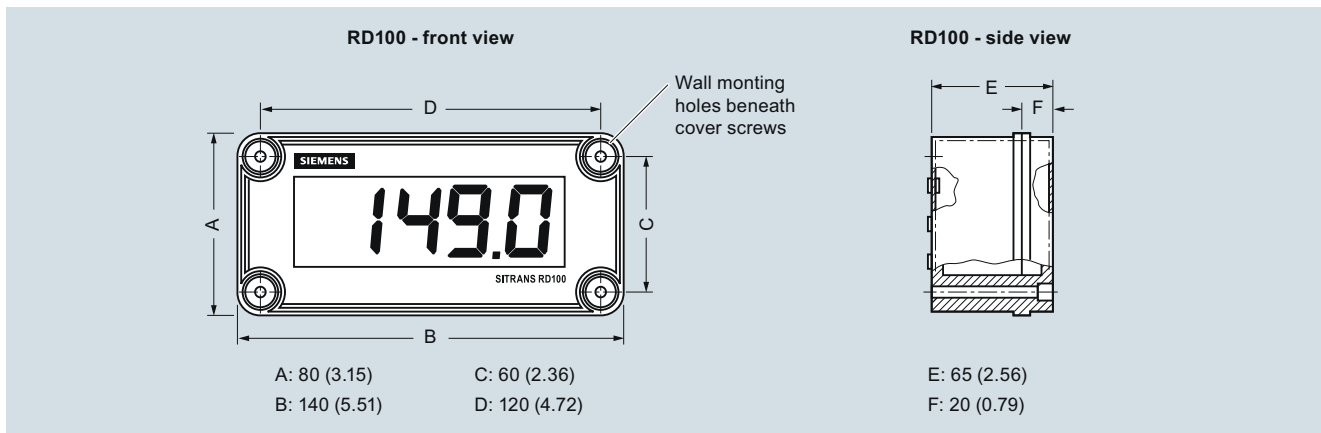

SITRANS RD100, dimensions in mm (inch)

Schematics

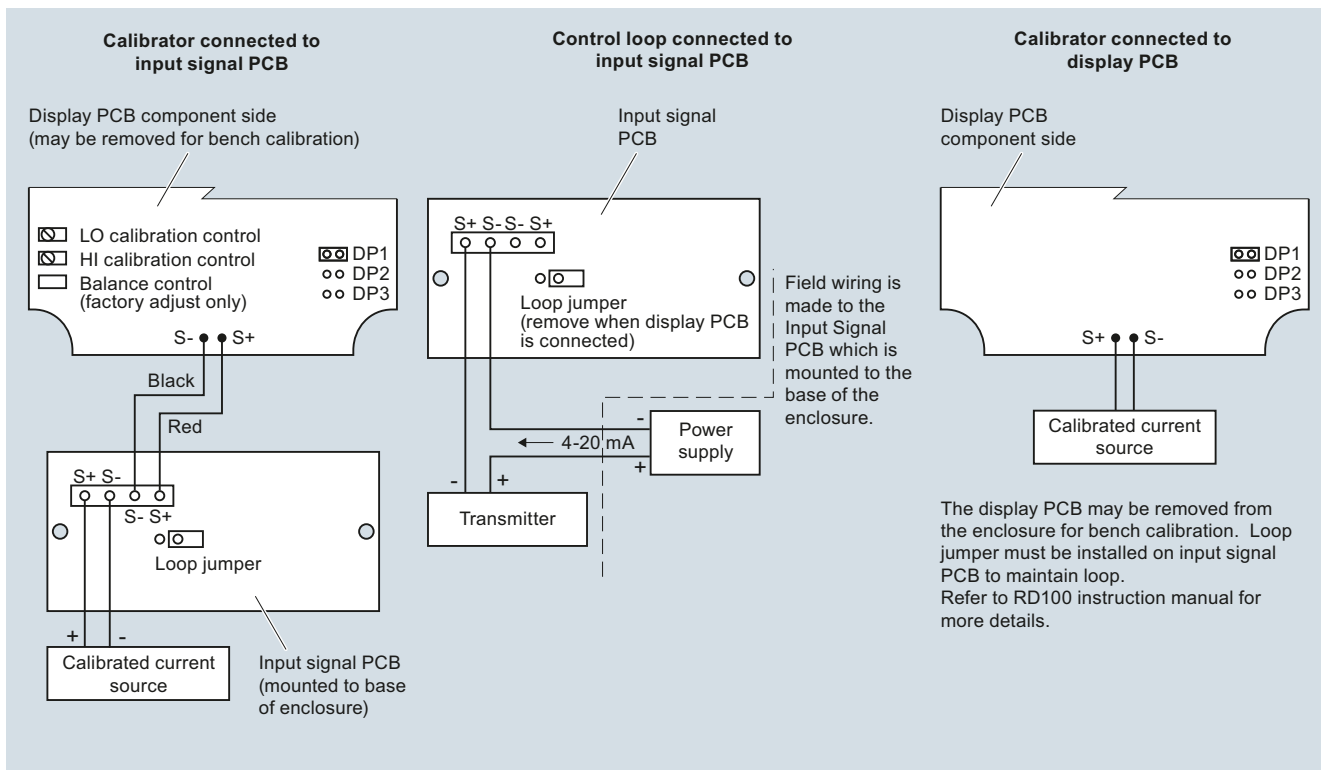

SITRANS RD100 connections

Supplementary Components

Displays

SITRANS RD200

Overview



The SITRANS RD200 is a universal input, panel mount remote digital display for process instrumentation.

Benefits

- Easy setup and programming via front panel buttons or remotely using RD software
- Display readable in sunlight
- Universal input: accepts current, voltage, thermocouple and RTD signals
- Single or dual 24 V DC transmitter power supply
- Serial communication using built in protocol or Modbus RTU
- Two optional relays for alarm indication or process control applications
- Linear or square root function supported
- Meter Copy feature to reduce setup time, cost or errors
- RD software supporting remote configuration, monitoring and logging for up to 100 displays
- Other features include: 4 to 20 mA Analog Output Option, Supports Pump Alternation control, and optional NEMA 4 and 4X FIELD ENCLOSURES
- 2X option for 30.5 mm (1.2 inch) high, red LED display

Application

The RD200 is a universal remote display for level, flow, pressure, temperature, weighing, and other process instruments.

Data can be remotely collected, logged and presented from as many as 100 displays on your local computer using the free downloadable RD Software.

The display accepts a single input of current, voltage, thermocouple, and RTD. This makes the RD200 an ideal fit for use with most field instruments.

The RD200 can be set up as a standard panel mount, or combined with optional enclosures to allow it to house up to 6 displays.

- Key Applications: Tank farms, pump alternation control, local or remote display of level, temperature, flow, pressure and weighing instrument values, PC monitoring and data logging with RD Software.

Technical specifications

Mode of operation	
Measuring principle	Analog to digital conversion
Measuring points	<ul style="list-style-type: none"> • 1 instrument • Remote monitoring of 100 instruments with PC and RD software
Input	
Measuring range	
<ul style="list-style-type: none"> • Current • Voltage • Thermocouple temperature 	<ul style="list-style-type: none"> • 4 ... 20 mA, 0 ... 20 mA • 0 ... 10 V DC, 1 ... 5 V, 0 ... 5 V • Type J: -50 ... +750 °C (-58 ... +1 382 °F) • Type K: -50 ... +1 260 °C (-58 ... +2 300 °F) • Type E: -50 ... +870 °C (-58 ... +1 578 °F) • Type T: -180 ... +371 °C (-292 ... +700 °F) • Type T, 0.1 resolution: -180.0 ... +371 °C (-199.9 ... +700 °F) • RTD temperature • 100 Ω RTD: -200 ... +750 °C (- 328 ... + 1 382 °F)
Output signal	
Output	<ul style="list-style-type: none"> • PDC output • 4 ... 20 mA (optional) • Modbus RTU
Relays	2 SPDT Form C relays, rated 3 A at 30 V DC or 3 A at 250 V AC, non-inductive, auto-initializing (optional)
Communications	<ul style="list-style-type: none"> • RS 232 with PDC or Modbus RTU • RS 422/485 with PDC or Modbus RTU
Accuracy	
4 ... 20 mA optional output	± 0.1 % FS ± 0.004 mA
Process input	± 0.05 % of span ± 1 count, square root: 10 ... 100 % FS
Thermocouple temperature input	<ul style="list-style-type: none"> • Type J: ± 1 °C (± 2 °F) • Type K: ± 1 °C (± 2 °F) • Type E: ± 1 °C (± 2 °F) • Type T: ± 1 °C (± 2 °F) • Type T, 0.1 Resolution: ± 1 °C (± 1.8 °F)
RTD temperature input	<ul style="list-style-type: none"> • 100 Ω RTD: ± 1 °C (± 1 °F)
Rated operating conditions	
Ambient conditions	
Storage temperature range	-40 ... +85 °C (-40 ... +185 °F)
Operating temperature range	0 ... 65 °C (32 ... 149 °F)
Design	
Weight	269 g (9.5 oz) (including options)
Material (enclosure)	<ul style="list-style-type: none"> • 1/8 DIN, high impact plastic, UL94V-0, color: gray • Optional plastic, steel and stainless steel (Type 304, EN 1.4301) NEMA 4 enclosures
Degree of protection	Type 4X, NEMA 4X, IP65 (front cover); panel gasket provided

Electrical connection	
• mA output signal	2-core copper conductor, twisted, shielded, 0.82 ... 3.30 mm ² (18 ... 12 AWG), Belden 8 760 or equivalent is acceptable
• Electrical connection and relay connection	Copper conductor according to local requirements, rated 3 A at 250 V AC
Power supply	
Input voltage option 1	85 ... 265 V AC, 50/60 Hz; 90 ... 265 V DC, 20 W max.
Input voltage option 2	12 ... 36 V DC; 12 ... 24 V AC, 6 W max.
Transmitter power supply	One or two isolated transmitter power supplies (optional)
• Single power supply	One 24 V DC ± 10 % at 200 mA max.
• Dual power supplies	Two 24 V DC ± 10 % at 200 mA and 40 mA max.
External loop power supply	35 V DC max.
Output loop resistance	• 24 V DC, 10 ... 700 Ω max. • 35 V DC (external), 100 ... 1 200 Ω max.
Displays and controls	
• Display	<ul style="list-style-type: none"> • 14 mm (0.56 inch) high LED • 2X option for 30.5 mm (1.2 inch) high, red LED • Numeric range from -1 999 ... +9 999 • 4 digits, automatic lead zero blanking • 8 intensity levels
• Memory	<ul style="list-style-type: none"> • Non-volatile • Stores settings for minimum of 10 years if power is lost
• Programming	<ul style="list-style-type: none"> • Primary: front panel • Secondary: meter copy or PC with SITRANS RD software
Certificates and approvals	
CE, UL, cUL	
Options	
• Enclosures	Plastic, steel and stainless steel (Type 304, EN 1.4301) NEMA 4 and 4X enclosures
• Mounting	<ul style="list-style-type: none"> • 2 inch (5.08 cm) pipe mounting kit (zinc plated seal) • 2 inch (5.08 cm) pipe mounting kit (stainless steel, Type 304, EN 1.4301)

Supplementary Components

Displays

SITRANS RD200

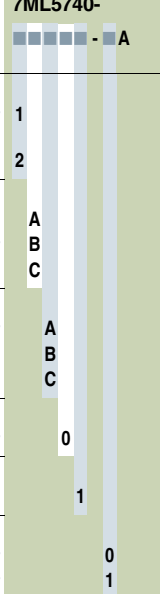
Selection and Ordering data	Article No.
SITRANS RD200 A universal input, panel mount remote digital display for process instrumentation.	7ML5740- 
Input voltage 85 ... 265 V AC, 50/60 Hz; 90 ... 265 V DC, 20 W max. 1 12 ... 36 V DC; 12 ... 24 V AC, 6 W max. 2	
Transmitter supply None A Single 24 V DC transmitter supply ¹⁾ B Dual 24 V DC transmitter supply ¹⁾²⁾ C	
Output None A 2 relays B 4 ... 20 mA output C	
Communication Modbus disabled 0	
Approvals CE, UL, cUL 1	
Display Size Standard 0 2X option for 30.5 mm (1.2 inch) high, red LED 1	

¹⁾ Available with input voltage option 1 only

²⁾ Available with output option C only

We can offer shorter delivery times for configurations designated with the Quick Ship Symbol . For details see page 9/5 in the appendix.

Available ex stock when configured with the following options only:
Input voltage: 1, Transmitter supply: B, Output : A, Communication: 0.

Selection and Ordering data	Article No.
Operating Instructions	
English	7ML1998-5JS01
Spanish	7ML1998-5JS21
German	7ML1998-5JS31
Note: The Operating Instructions should be ordered as a separate line item. This device is shipped with the Siemens Milltronics manual CD containing Quick Starts and Operating Instructions.	
Other Operating Instructions	
SITRANS RD Enclosures, English	7ML1998-5JX01
SITRANS RD Enclosures, German	7ML1998-5JX31
SITRANS RD Serial Adapters, English	7ML1998-5JV01
SITRANS RD Serial Adapters, German	7ML1998-5JV31
SITRANS RD Software, English	7ML1998-5JW01
SITRANS RD Software, German	7ML1998-5JW31

Selection and Ordering data	Article No.
Accessories	
SITRANS RD200 copy cable 2.1 m (7 ft)	7ML1930-1BR
SITRANS RD200 RS 232 serial adapter (copy cable included)	7ML1930-1BS
SITRANS RD200 RS 422/485 serial adapter (copy cable included)	7ML1930-1BT
RS 232 to RS 422/485 isolated converter	7ML1930-1BU
RS 232 to RS 422/485 non-isolated converter	7ML1930-1BV
SITRANS RD200 RS 232 and RS 485 isolated multi-input adapter board	7ML1930-1BW
USB to RS 422/485 isolated converter	7ML1930-1BX
USB to RS 422/485 non-isolated converter	7ML1930-1BY
USB to RS 232 converter	7ML1930-1DC
RD Software CD for 1 ... 100 displays	7ML1930-1CC
Low cost polycarbonate plastic enclosure for 1 display	7ML1930-1CF
2 inch (5.08 cm) pipe mounting kit (zinc plated seal) only available with 7ML1930-1CF	7ML1930-1BP
2 inch (5.08 cm) pipe mounting kit (stainless steel, Type 304, EN 1.4301) only available with 7ML1930-1CF	7ML1930-1BQ
Thermoplastic enclosure	
For use with 1 display	7ML1930-1CG
For use with 2 displays	7ML1930-1CH
For use with 3 displays	7ML1930-1CJ
For use with 4 displays	7ML1930-1CK
For use with 5 displays	7ML1930-1CL
For use with 6 displays	7ML1930-1CM
Stainless steel enclosure (Type 304, EN 1.4301)	
For use with 1 display	7ML1930-1CN
For use with 2 displays	7ML1930-1CP
For use with 3 displays	7ML1930-1CQ
For use with 4 displays	7ML1930-1CR
For use with 5 displays	7ML1930-1CS
For use with 6 displays	7ML1930-1CT
Steel enclosure	
For use with 1 display	7ML1930-1CU
For use with 2 displays	7ML1930-1CV
For use with 3 displays	7ML1930-1CW
For use with 4 displays	7ML1930-1CX
For use with 5 displays	7ML1930-1CY
For use with 6 displays	7ML1930-1DA

Dimensional drawings

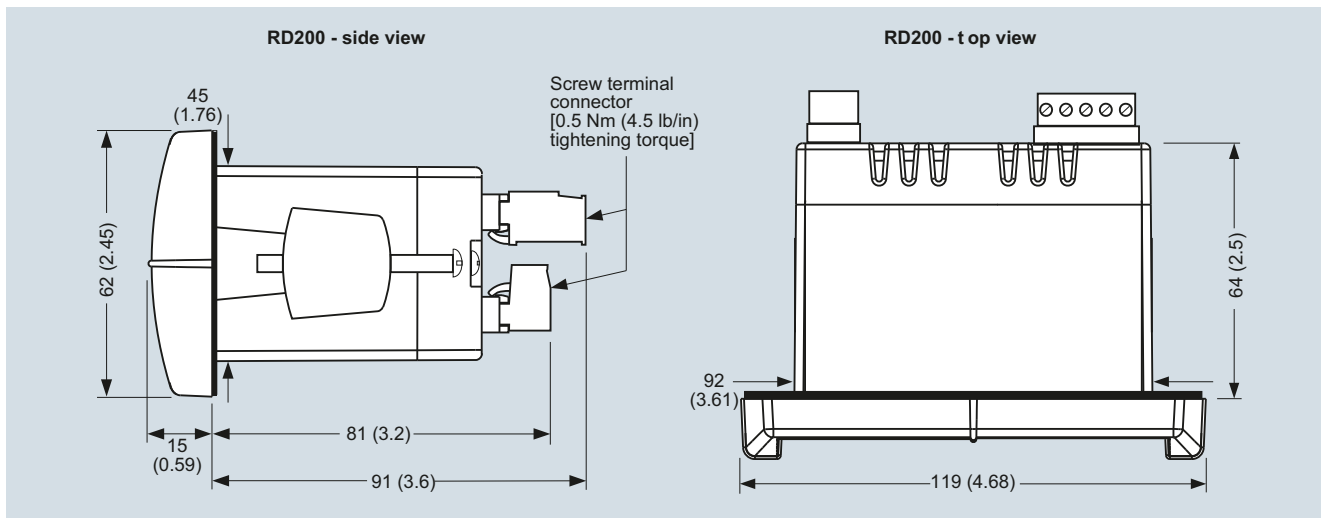

SITRANS RD200, dimensions in mm (inch)

Schematics

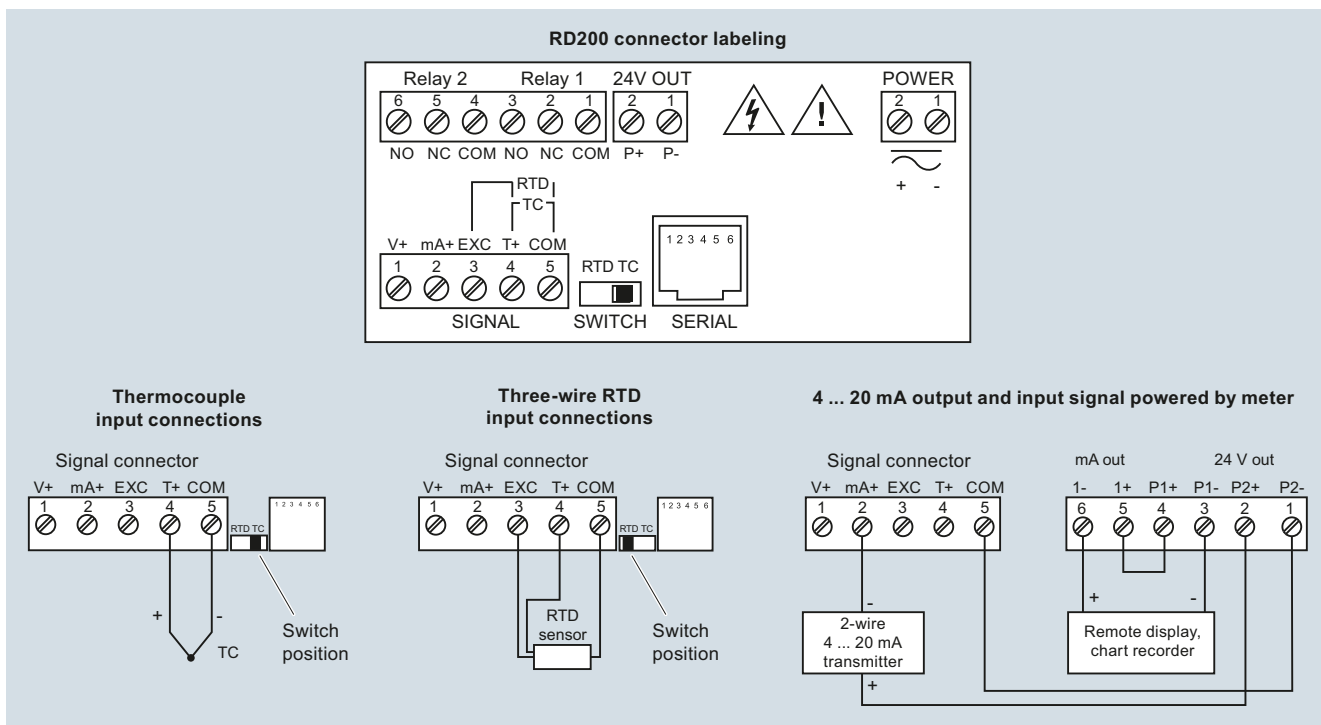

SITRANS RD200 connections

Supplementary Components

Remote data manager

SITRANS RD500

Overview



The SITRANS RD500 is a remote data manager providing remote monitoring through integrated web access, alarm event handling, and data capture for instrumentation and other devices.

Benefits

- RD500 supports report and alarm events via email, SMS, and FTP transfer
- Web provides worldwide access to instrument data and RD500 configuration and setup
- Simple configuration using a standard web browser, no programming or additional software required.
- Offers scalability with optional I/O modules for current (4 to 20 mA), voltage (0 to 10 V), thermocouple (TC), resistance temperature detector (RTD), and digital input, output and counter
- 10 base-TI 100 Base-TX Ethernet and support for GSM, GPRS, 3G, and PSTN provide flexible remote communications options
- Supports up to 128 devices with the flexible I/O modules and supports addressing for Modbus serial devices via RS 232 and RS 485 serial ports
- Integrated FTP server and client supports FTP data synchronization to central servers
- Compact flash slot supports up to 2 gigabytes of expandable memory for data capture and storage, 1 gigabyte industrial compact flash card included
- Log files formats are CSV (comma separated values) for data files and HTML for report files
- Supports modbus TCP via Ethernet and GPRS for easy integration into control systems
- Optional 3G modem offers VPN support

Application

The RD500 is an easy-to-use remote data monitoring solution, using a web-based application and hardware modules. The unique modular approach allows a variety of process signals to be monitored, while the serial ports allow data to be collected from Modbus RTU devices.

The RD500 comprises a master communications module, and up to 16 slave modules. Various module types are available, allowing up to a maximum of 128 conventional inputs and outputs. The RD500's serial ports can support addressing for Modbus RTU slave devices including field instruments.

The RD500's built-in web server, FTP, and email client allows the process to be monitored remotely. Alarm notifications are communicated through email and SMS text messages to one or more recipients to ensure that appropriate actions are taken by personnel.

The RD500 supports modems, providing flexibility for applications in which GSM/GPRS/3G cellular or landline connectivity is desired.

The RD500 is configured via a web-based interface - a standard browser is all the software you need to configure your system.

- Key Applications: Remote monitoring, inventory management, web enabled instrumentation or other devices

Supplementary Components

Remote data manager

SITRANS RD500

Technical specifications

Mode of operation	
Measuring principle	Remote data monitor
Measuring points	<ul style="list-style-type: none"> Up to 128 standard input/outputs Addressing for Modbus serial devices
Input	See table on page 7/18
Output	See table on page 7/18
Accuracy	See table on page 7/18
Rated operating conditions	
Storage temperature range	-30 ... +70 °C (-22 ... +158 °F)
Operating temperature	0 ... 50 °C (32 ... 122 °F)
Operating and storage humidity	80 % max relative humidity, non-condensing, from 0 ... 50 °C (32 ... 122 °F)
Design	
Material (enclosure)	High impact plastic and stainless steel
Installation category	1
Pollution degree	2
Weight	456.4 g (15.1 oz)
Mounting	Snaps onto standard DIN style top hat (T) profile mounting rails according to EN 50022 – 35 x 7.5 and – 35 x 15
Power	
	24 V DC ± 10 %
	400 mA min. (1 module)
	3.5 Amps max. (16 modules)
	Must use Class 2 or SELV-rated power supply
Display	
Status LEDs	<ul style="list-style-type: none"> STS - status LED indicates condition of master TX/RX - transmit/receive LEDs show serial activity Ethernet - link and activity LEDs CF - CompactFlash LED indicates card status and read/write activity
Memory	
On-board user memory	4 Mbytes of non-volatile Flash memory
On-board SDRAM	2 Mbytes
Memory card	CompactFlash Type II slot for Type I and Type II cards; 1 Gbytes (optional 2 Gbytes)
Certificates and approvals	
Safety	<ul style="list-style-type: none"> UL listed to U.S. and Canadian safety standards for use in Class I, II and III, Division 1 and 2 hazardous locations CE, C-TICK

Communication

USB/PG port	Adheres to USB specifications 1.1. Device only using Type B connection.
Serial ports	Format and baud rates for each port are individually software programmable up to 115, 200 baud
RS 232/PG port	RS 232 port via RJ12
Comms ports	RS 422/485 port via RJ45 and RS 232 port via RJ 12
Ethernet port	10 BASE-T/100 BASE-TX; RJ45 jack is wired as a NIC (Network Interface Card)

Dimensional drawings

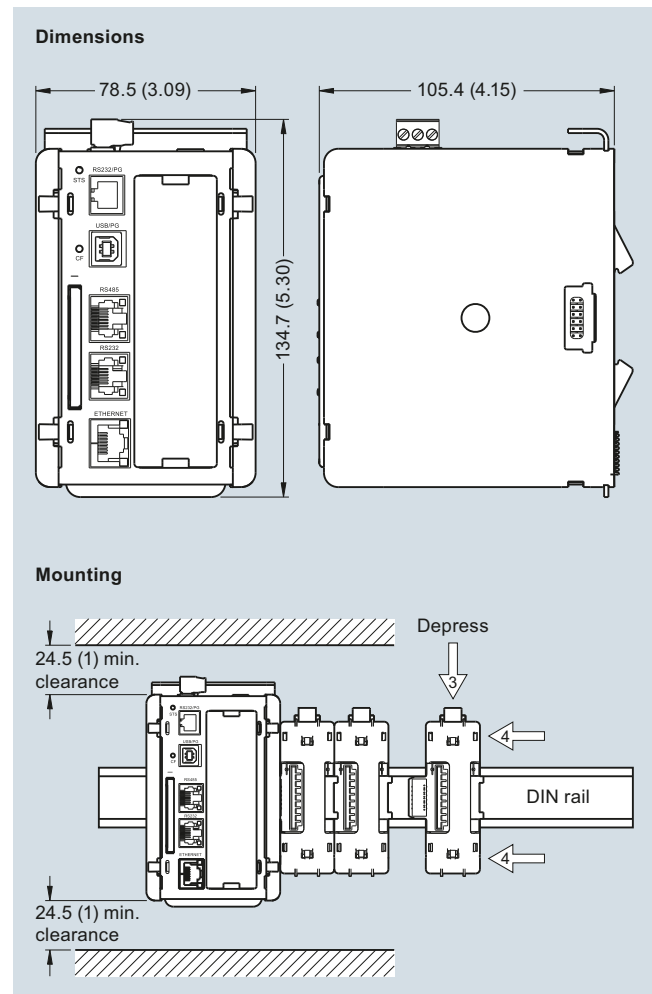

SITRANS RD500, dimensions in mm (inch)

Supplementary Components

Remote data manager

SITRANS RD500

SITRANS RD500 Module Specifications

	8 inputs, 6 solid state outputs	8 inputs, 6 relay outputs	8 channel, 4 ... 20 mA	8 channel ± 10 V	6 channel, RTD	8 channel thermocouple module
Article number	7ML1930-1ES	7ML1930-1ER	7ML1930-1EP	7ML1930-1EQ	7ML1930-1ET	7ML1930-1EU
Application	8 inputs, 6 outputs used to monitor contact or sensor inputs	8 inputs, 6 outputs used to monitor contact or sensor inputs	16 bit analog input module provides high density signal measurement for data monitoring applications and accepts 0/4 ... 20 mA process signals	16 bit analog input module provides high density signal measurement for data monitoring applications and accepts ± 10 V process signals	16 bit analog input module provides high-density signal measurement for data acquisition applications and accepts various RTD inputs	16 bit thermocouple input module provides high density signal measurement for data acquisition applications and accepts wide range of thermocouple types
Accuracy	Not applicable	Not applicable	± 0.1 % of span	± 0.1 % of span	± (0.2 % of span, 1 °C) 0 ... 50 °C (32 ... 122 °F); ± (0.1 % of span, 1 °C) 18 ... 28 °C (64 ... 82 °F); includes NIST conformity, A/D conversion errors, temperature coefficient and linearization conformity at 23 °C after 20 minutes warm-up	± (0.3 % of span, 1 °C); includes NIST conformity, cold junction effect, A/D conversion errors, temperature coefficient and linearization conformity at 23 °C after 20 minute warm-up
Mounting	Snaps onto standard DIN style top hat (T) profile mounting rails according to EN 50022 – 35 x 7.5 and - 35 x 15					
Inputs	Dip switch selectable for sink or source	Dip switch selectable for sink or source Max. voltage • 30 V DC, reverse polarity protected Off voltage • < 1.2 V On voltage • > 3.8 V Input frequency • Filter switch on: 50 Hz • Filter switch off: 300 Hz	8 single-ended Ranges • 0 ... 20 mA or 4 ... 20 mA Resolution • Full 16-bit sample time: 50 ... 400 ms depending on number of enabled inputs	8 single-ended Ranges • 0 ... 10 V DC or ± 10 V DC Resolution • Full 16-bit sample time: 50 ... 400 ms depending on number of enabled inputs	6 single-ended Resolution • Full 16-bit sample time: 67 ... 400 ms depending on number of enabled inputs	8 single-ended Resolution • Full 16-bit sample time: 50 ... 400 ms depending on number of enabled inputs
Outputs	Solid state output, switched DC, contact rating 1 A DC max.	Form A, NO pairs share common terminals: 1 & 2, 3 & 4, 5 & 6 current rating by pair: 3 Amps at 30 V DC/125 V AC resistive 1/10 HP at 125 V AC	Not applicable	Not applicable	Not applicable	Not applicable

Supplementary Components

Remote data manager

SITRANS RD500

Selection and Ordering data	Article No.
SITRANS RD500	7ML5750-
The SITRANS RD500 is a remote data manager providing integrated web access, alarm event handling and data capture for instrumentation.	A 0 0 - 0
Communications Connection	
Ethernet ¹⁾	1
Digital Communications to Instruments	
RS 485 Modbus RTU	A

¹⁾ Configuration limited to 16 modules.

- We can offer shorter delivery times for configurations designated with the Quick Ship Symbol ●. For details see page 9/5 in the appendix.

Selection and Ordering data	Article No.
Input configuration modules	
Note: one RD500 supports 16 input modules maximum	
RD500 8 channel 0 (4) ... 20 mA input module	● 7ML1930-1EP
RD500 8 channel ± 10 V input module	● 7ML1930-1EQ
RD500 8 digital inputs/pulse counters, 6 relay outputs module	● 7ML1930-1ER
RD500 8 digital inputs/pulse counters, 6 solid state outputs module	● 7ML1930-1ES
RD500 6 channel input, RTD module	● 7ML1930-1ET
RD500 8 channel thermocouple module	● 7ML1930-1EU
Optional equipment	
3G external ethernet modem with antennae MTCBA-H4-EN2-P1	7ML1930-1GJ
Multitech GPRS modem, internal (including antennae)	7ML1930-1EY
Industrial CompactFlash card, 2 GB ¹⁾	7ML1930-1FB
Industrial CompactFlash card, 1 GB ²⁾	7ML1930-1FC
RJ11 serial to terminal block RS 232	7ML1930-1FD
RJ45 serial to terminal block RS 485	7ML1930-1FE
GPRS Spare modem antenna	7ML1930-1FF
RD500 Spare Module base	7ML1930-1FG
RD500 Spare End terminator	7ML1930-1FH
Ethernet Cat 5e Red X/O cable for configuration, 1,52 m (5 ft)	7ML1930-1FM
USB cable type A/B	7ML1930-1FN
Remote mount external antenna 17 ft (5 m)	7ML1930-1FY
Operating Instructions	
Application manual, English	7ML1998-5MA01
Application manual, German	7ML1998-5MA31
Note: Additional Operating Instructions should be ordered as a separate line item. This device is shipped with the Siemens Milltronics manual CD containing Quick Starts and Operating Instructions.	

Selection and Ordering data	Article No.
Other Operating Instructions	
RD500 Remote Data Manager manual, English: web access, alarm event handling, and data capture	7ML1998-5MK01
RD500 Remote Data Manager manual, German: web access, alarm event handling, and data capture	7ML1998-5MK31
RD500 8 channel 0 (4) ... 20 mA input module manual, English	7ML1998-5MB01
RD500 8 channel 0 (4) ... 20 mA input module manual, German	7ML1998-5MB31
RD500 8 channel ±10 V input module manual, English	7ML1998-5MC01
RD500 8 channel ±10 V input module manual, German	7ML1998-5MC31
RD500 8 inputs, 6 relay outputs module manual, English	7ML1998-5MD01
RD500 8 inputs, 6 relay outputs module manual, German	7ML1998-5MD31
RD500 8 inputs, 6 solid state outputs module manual, English	7ML1998-5ME01
RD500 8 inputs, 6 solid state outputs module manual, German	7ML1998-5ME31
RD500 6 channel input, RTD module manual, English	7ML1998-5MF01
RD500 6 channel input, RTD module manual, German	7ML1998-5MF31
RD500 8 channel thermocouple module manual, English	7ML1998-5MJ01
RD500, 8 channel thermocouple module manual, German	7ML1998-5MJ31

¹⁾ External modem includes antenna, power cord and cable

²⁾ 1 Gbyte industrial grade compact flash card included

- We can offer shorter delivery times for configurations designated with the Quick Ship Symbol ●. For details see page 9/5 in the appendix.

7

Supplementary Components

Remote data manager

SITRANS RD500

Schematics

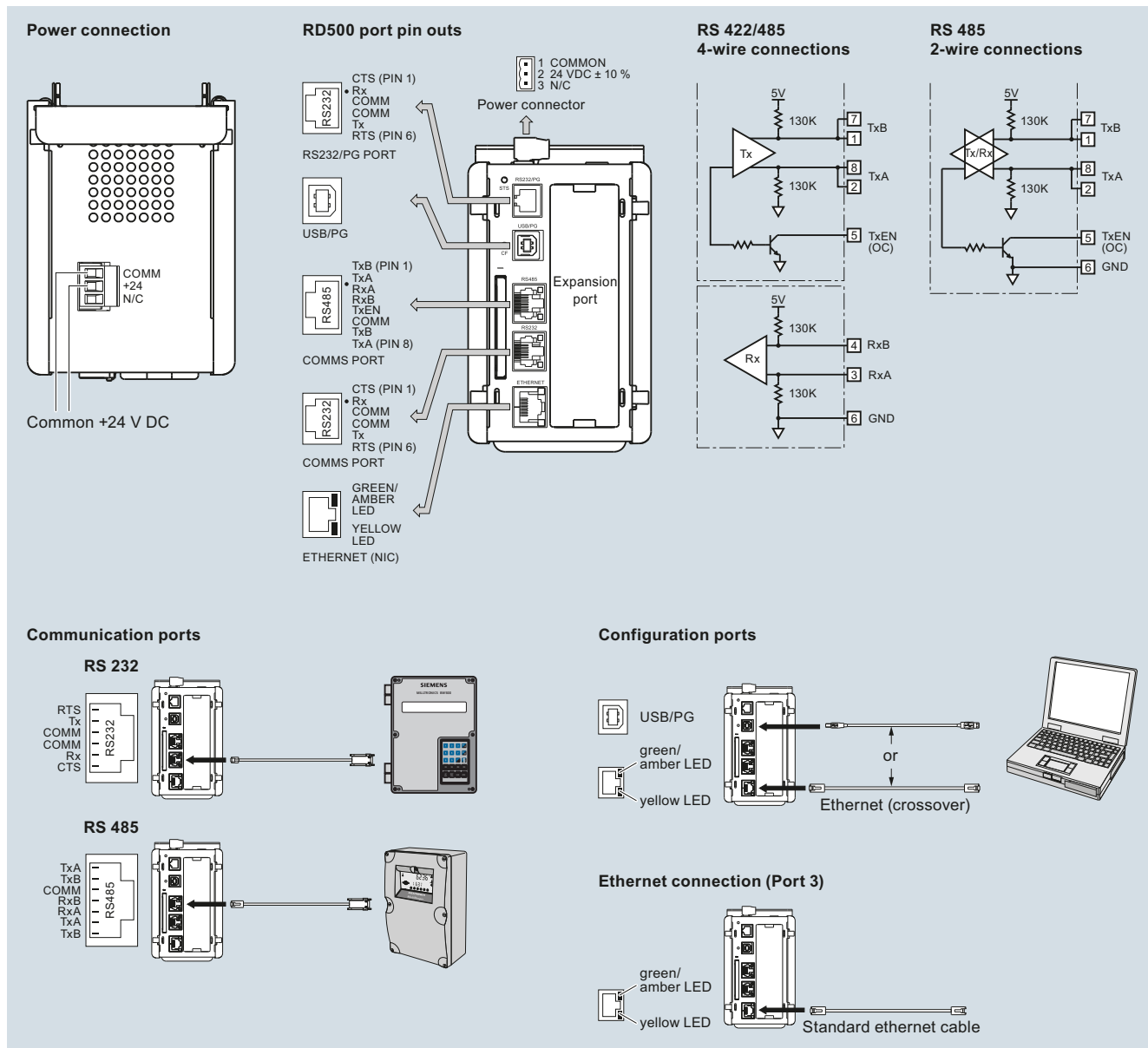

SITRANS RD500 connections

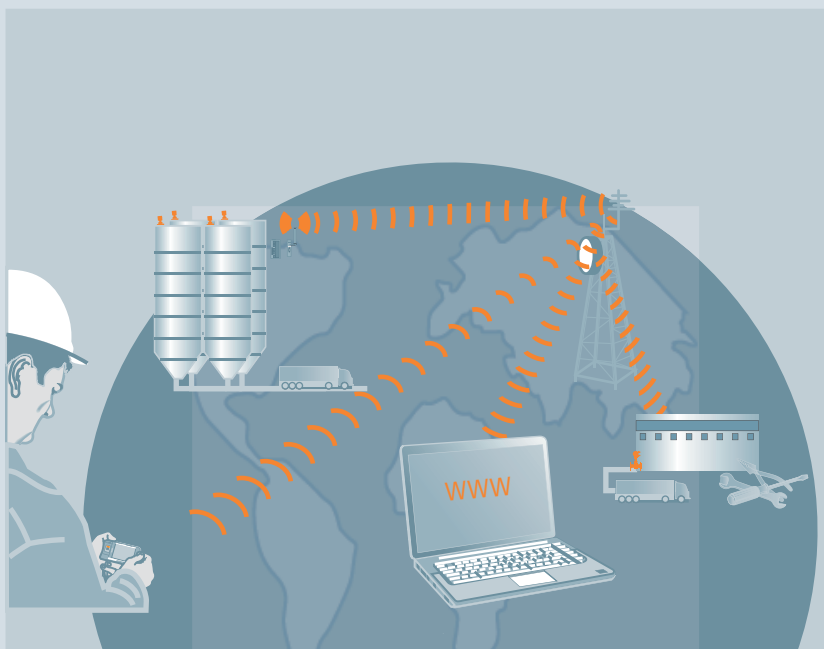

With SITRANS RD500, monitor inventory levels, process, environmental, and remote maintenance applications, and get web access to most types of field instrumentation, including flow, level, pressure, temperature measurement, and weighing.

Supplementary Components

WirelessHART products

SITRANS AW200 - WirelessHART adapter

Overview



SITRANS AW200 WirelessHART adapter

The SITRANS AW200 WirelessHART adapter is a battery-powered communication component, which integrates HART and 4 to 20 mA field devices into a WirelessHART network. On the wireless communication side, the adapter supports the WirelessHART standard. HART and 4 to 20 mA field devices are connected on the field device side.

The SITRANS AW200 WirelessHART adapter

- Support the WirelessHART standard (HART V 7.1)
- Features a very high degree of security for wireless data transmission
- Integrates one 4 to 20 mA field device or up to four HART field devices (in multidrop mode) into a WirelessHART network
- Features intelligent energy management for the power supply of connected field devices
- Can be easily parameterized using SIMATIC PDM

Benefits

- High quality and service life
- Save on wiring costs for difficult installation conditions (e.g. moveable equipment parts) or for temporary installations
- Subsequent integration of an installed field device with HART interface into maintenance and diagnostic systems if the control system does not feature the required communication mechanisms. This application is described in Section 9 of this catalogue under "WirelessHART - Technical Description".
- Proven HART devices can continue to be used for wireless communication, without any limitations.
- Field devices with a 4 to 20 mA interface (without HART) can also be connected.
- Intelligent energy management to achieve the best possible life time for the installed battery unit.
- Optimum addition to wired communication and expansion of solution options for system solutions in process automation.
- Burst mode and event notification parameterization for the adapter and connected field devices.

Application

The WirelessHART adapter can be used in a number of different applications, e.g.

- Access to installed basis
Diagnostic information is obtained from existing wired HART devices through a permanent electrical connection of a WirelessHART adapter, and is sent to an asset management software near the system, e.g. SITRANS MDS.
- Status monitoring of the plant
Wireless devices are mounted at critical points in the plant, which are not usually connected to the control room due to difficult accessibility or extensive costs for wiring. Better data flow and diagnostics increase the system's reliability, transparency and safety.
- Process optimization
A temporary installation of a standard 4 to 20mA or HART device together with the WirelessHART adapter SITRANS AW200 allows flexible monitoring and plant optimization at lower costs and reduced effort.
- Process monitoring
Measured values from e.g. tanks or silos are transmitted to a superordinate system in regular time intervals, together with the device and battery status.

Design

The SITRANS AW200 WirelessHART adapter consists of

- A housing with mounted antenna
- Electronics
- A high-performance lithium battery unit

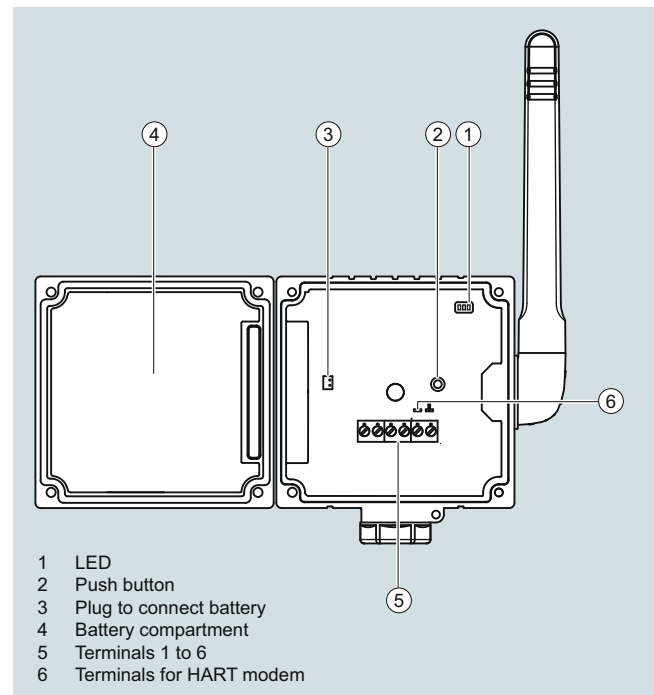

SITRANS AW200 WirelessHART adapter, assembly

The housing can be opened by loosening 4 screws. This allows to access the electronics and battery unit. The battery unit can be removed without the use of tools, since it is connected to the housing with clips.

The back of the housing features a connection part with a fixing nut onto which different replaceable connecting pieces can be screwed to mount the adapter directly on a field device.

The bottom of the housing contains an optional cable opening which can be used for a cable gland. In the case of an offset mounted adapter, it is possible to feed up to 2 cables.

Supplementary Components

WirelessHART products

SITRANS AW200 - WirelessHART adapter

Function

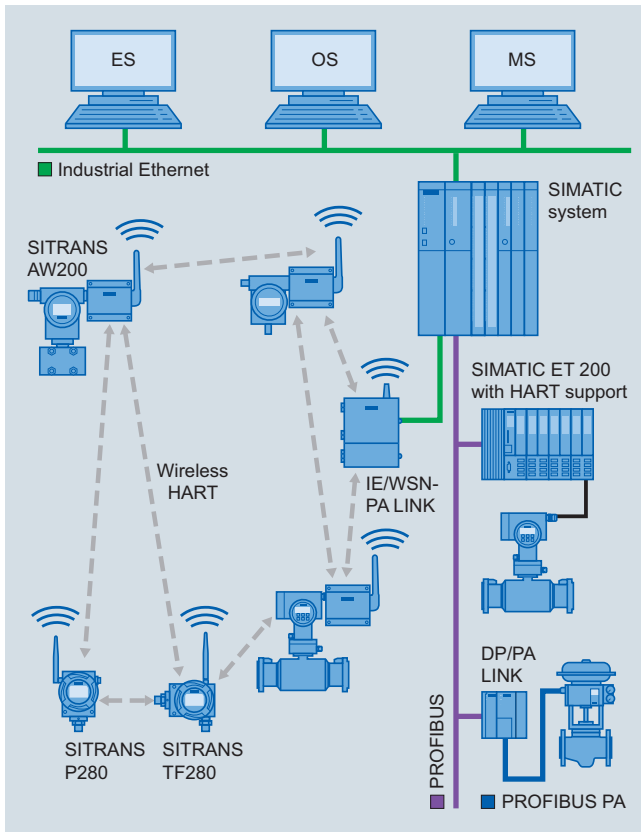

SITRANS AW200 WirelessHART adapter functional diagram

Measured values and diagnostic information of connected field devices with HART communication are transmitted via a wired connection to the WirelessHART adapter. The adapter transmits this information in the form of wireless signals to the IE/WSN-PA LINK, the Siemens WirelessHART gateway. From here, the information is available to the network of the system.

Where a field device with a 4 to 20 mA output signal is connected to the adapter, only the measured value will be transmitted.

Following parameterization and integration into a WirelessHART network, each WirelessHART adapter is able to recognize its neighbors. It notes the strength of the wireless signal, synchronizes itself, receives network information and then establishes connections to the neighbors in the wireless network. A WirelessHART network organizes itself. Manual settings for organizational purposes are not required.

Two- and four-wire field devices can be connected to a WirelessHART adapter. In the case of a connected two-wire field device, power can be supplied by the adapter. Where multiple two-wire field devices are connected (multi drop operation), the adapter must be connected to an external power supply.

The WirelessHART adapter may also be connected in parallel to an already existing installation which consists of a power supply and a HART field device.

Interface	Connection	Function
1	—	Power supply for the field device
2	—	HART/4 ... 20 mA
3	—	External supply/Dimensions
4	—	High-resistance HART connection
5, 7	—	High-resistance HART connection
6, 8	—	Mass, high-resistance connection

Terminal block with 6 screw connection clamps

Parameterization

The SITRANS AW200 configured via HART. This can be done using a handheld communicator or even more conveniently with a HART modem and the SIMATIC PDM parameterization software.

Initial start-up of the adapter is usually carried out via SIMATIC PDM and HART modem or a handheld communicator. During initial start-up, the network ID and join key is set up in the adapter, among others. Using these parameters, the adapter is then integrated into an existing WirelessHART network.

Once it is integrated into the network, the adapter and connected HART devices can be conveniently operated via the WirelessHART network or with the onsite HART modem.

Siemens HART field devices for the adapter

HART and 4 to 20mA field devices can be connected to the SITRANS AW200 WirelessHART adapter. Depending on the electrical data of the field devices, they can receive their power supply from the WirelessHART adapter or will require an external power supply. Please find current information about connectivity to field devices from Siemens as FAQ under <http://www.siemens.com/automation/service&support>.

Note:

Siemens will only approve the Siemens HART field devices listed there for the adapter, and will only supply technical support for these devices.

Based on HART specifications, it is generally possible to connect devices that are not listed, however with the following limitations:

- All warranties and liabilities will be excluded.
- No technical support

Supplementary Components

WirelessHART products

SITRANS AW200 - WirelessHART adapter

Technical specifications

Input		Design	
Input	Point-to-Point connection to a HART field device or Point-to-Point connection to a 4 ... 20 mA field device or Up to four HART field devices with external power supply which are integrated using the multidrop method	Weight	0.5 kg without battery, 0.75 kg with battery
Communication	HART communication using multidrop method, 4 ... 20 mA power signal with Point-to-Point connection	Enclosure	
Protocol	HART V7 (compatible with previous HART versions)	• Material	Polyester (PBT FR)
Transfer rate	1200 bits/s using HART multidrop method	• Cable entry	2x M20x1.5
		Degree of protection	IP65, IP66; NEMA 4
		Antenna	Omnidirectional dipolar aerial, vertical rotation
		Mounting adapter	M20 x 1.5 on M20 x 1.5, M20 x 1.5 on G $\frac{1}{2}$, M20 x 1.5 on $\frac{1}{2}$ "- 14 NPT, M20 x 1.5 on $\frac{3}{4}$ " -14 NPT
Output		Power supply	
Communication	WirelessHART V7	Battery	Lithium thionylchlorid high-performance battery unit
Transfer rate	Nominal 250 kBits/s	Supply voltage	5 ... 7.2 V DC
Transmission frequency band	2.4 GHz (ISM band)	Capacity	19 Ah at 20 °C
Range (under reference conditions)	Outside areas up to 250 m, within buildings up to 50 m	Service life	Up to 5 years, depending on update rate, connected field device and ambient conditions
RF signal strength	Can be configured: 0 dBm and 10 dBm	Voltage supply for one field device (independent of multidrop)	
Output signals		• No-load voltage	8 ... 23 V DC
• WirelessHART adapter	Measured voltage and up to three other variables may be selected from the following: adapter temperature, battery voltage, energy consumed, expected battery life time	• Current	4 ... 20 mA DC (as per NAMUR recommendation NE 43)
• 4 ... 20 mA field device	Scaled or linearized process values	• Fault current	I ≤ 3.6 mA or I ≥ 21 mA
• HART field device	Up to four process variables, can be configured via PDM or gateway	• Protection	Short-circuit proof, activated at voltages > 25 mA
		External voltage supply for one or more field devices (multidrop)	
		• Voltage	< 30 V DC
		• Current	< 25 mA
Measuring accuracy (as per reference conditions IEC 61298-2)		Certificates and approvals	
Max. measuring error (4 ... 20 mA circuit)	0.125 % re: measuring range	Wireless communication approvals	ETSI (R&TTE) FCC Part 15.247 for wireless applications in the 2.4 GHz transmission frequency band EN 300328
Effect of ambient temperature (4 ... 20 mA circuit)	5 μ A/10 K		
Rated conditions			
Location	Outside/Inside		
Ambient conditions			
• Ambient temperature	-40 ... +80 °C (-40 ... +176 °F) The capacity of the battery decreases rapidly if ambient temperature falls below -30 °C.		
• Storage temperature	-40 ... +85 °C (-40 ... +185 °F) without batteries < 21 °C with batteries		
• Relative humidity	Max 90 % at 25 °C (non-condensating)		
• Resistance to vibration	20 ≤ f ≤ 2000 Hz: 0,01 g ² /Hz as per IEC 68-2-64		
• Shock resistance	15 g, 11 ms as per IEC 68-2-27		
Electromagnetic compatibility	As per EN 61326, EN 301 489-1/17 and NAMUR NE 21		

Selection and ordering data	Article No.
SITRANS AW200 adapter for WirelessHART communication	7MP3112 - 0 - 0AA0
WirelessHART adapter AW200 with 4 ... 20 mA- or HART interface Without battery	1
Power supply Battery powered	A
Certificates and approvals¹⁾ Without	A
Enclosure Polyester	0
Accessories	
Lithium battery for SITRANS AW200	7MP3990-0AA00
Thread adapter for direct mounting of the adapter to a field device	
• M20 thread adapter	7MP3990-0BA00
• Thread adapter G½	7MP3990-0BB00
• Thread adapter ½" - 14 NPT	7MP3990-0BC00
• Thread adapter ¾" - 14 NPT	7MP3990-0BD00
Mounting bracket for attaching to wall/pipe, material: stainless steel SS304, including cable gland	7MP3990-0CA00

¹⁾ Additional approvals in process.

Supplementary Components

WirelessHART products

SITRANS AW200 - WirelessHART adapter

Dimensional drawings

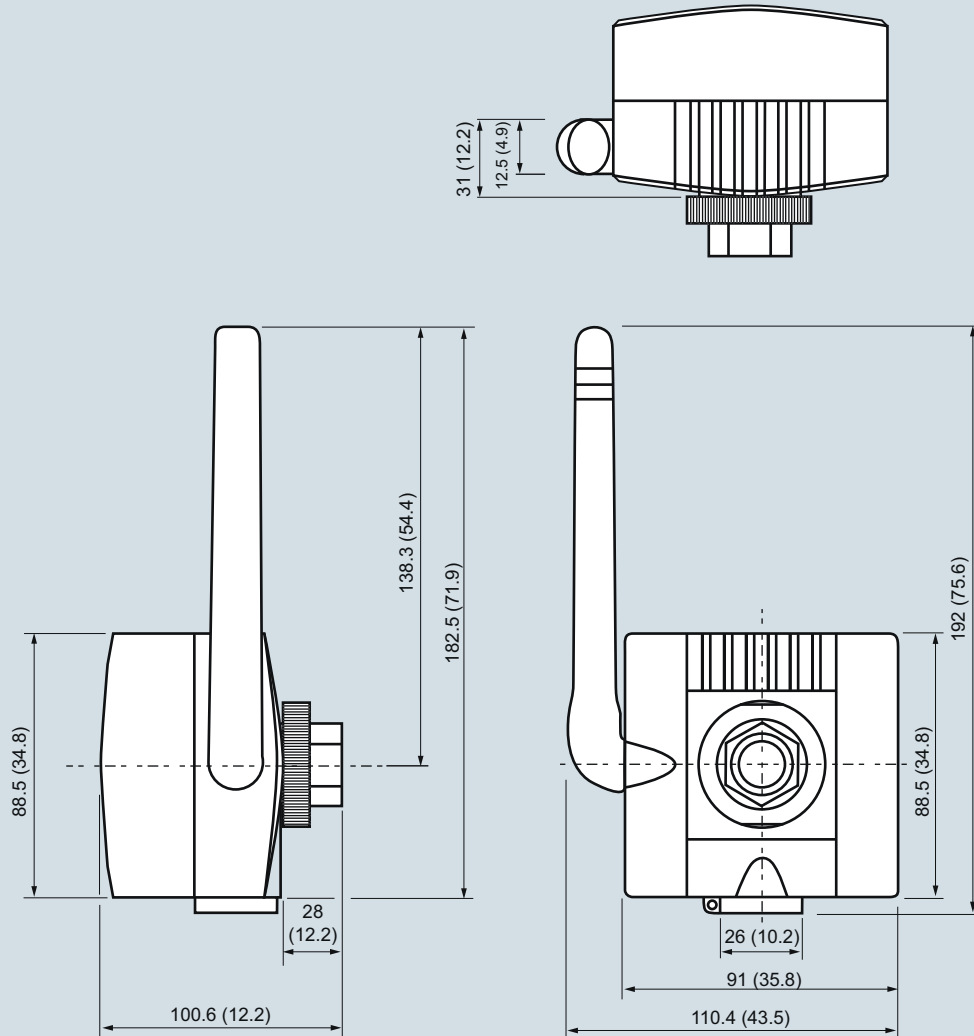

SITRANS AW200 WirelessHART adapter, dimensions in mm (inch)

SITRANS AW200 - WirelessHART adapter

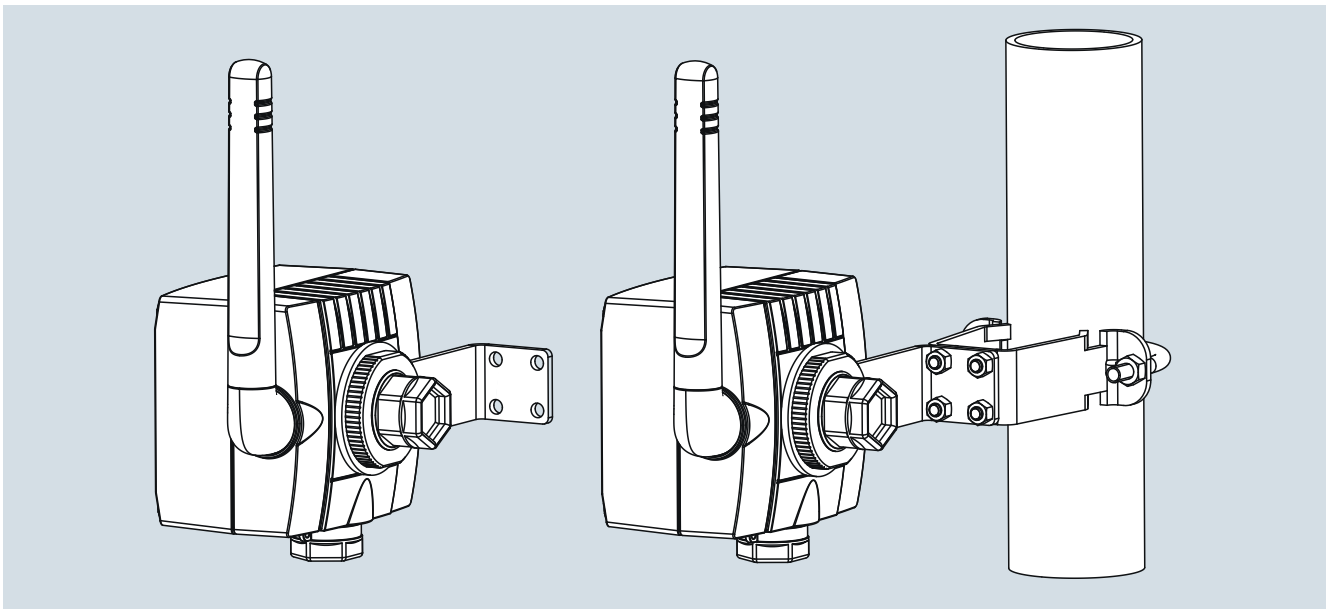

SITRANS AW200 with built-in mounting bracket for wall or pipe mounting

Schematics

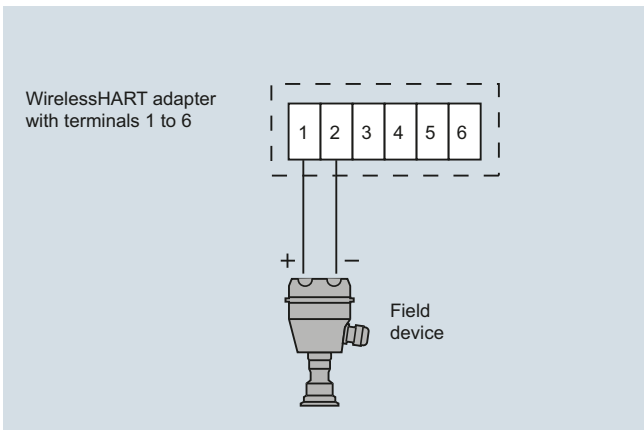

Connection of a two-wire field device, power supply provided by adapter

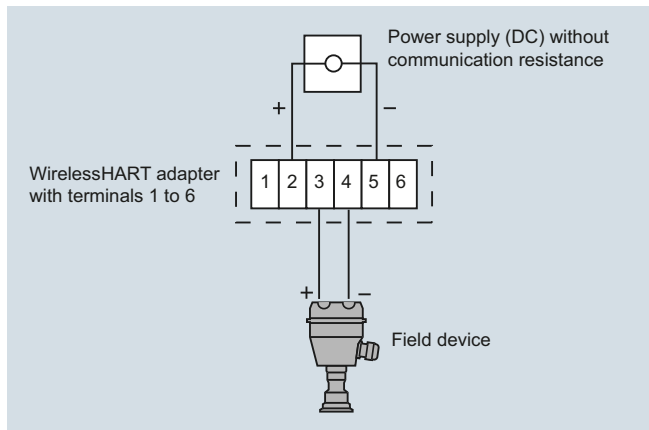

Connection of a two-wire field device with external power supply

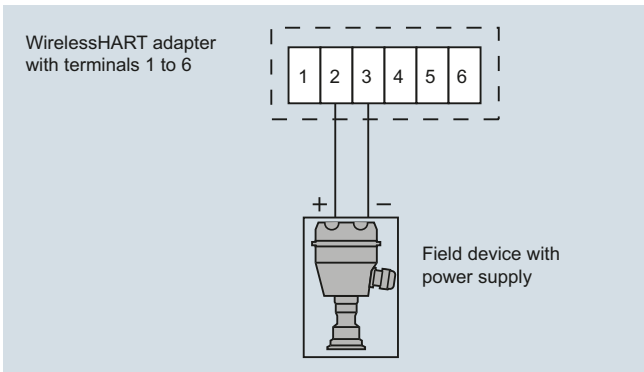

Connection of a four-wire field device

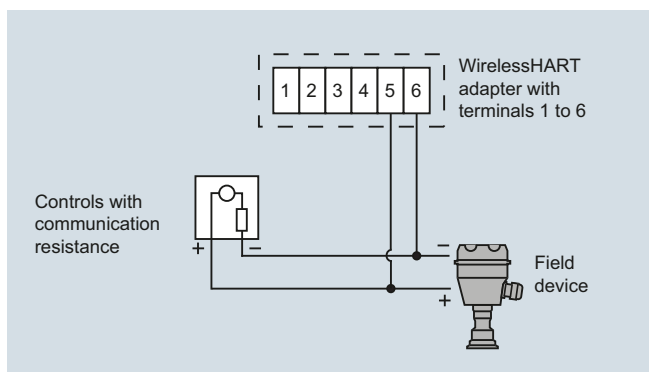

Connection of adapter parallel to wired 4 to 20 mA communication

Supplementary Components

WirelessHART products

SITRANS AW210 - WirelessHART adapter

Overview



SITRANS AW210 WirelessHART adapter

The WirelessHART adapter SITRANS AW210 is a communication component which can integrate a wide range of field devices into a WirelessHART network. On the wireless communication side, the adapter supports the WirelessHART standard. HART and 4 to 20 mA field devices are connected on the field device side.

The WirelessHART adapter SITRANS AW210

- Supports the WirelessHART standard (HART V 7.1)
- Features an extremely high degree of security for wireless data transmission.
- Integrates a 4 to 20 mA field device into a WirelessHART network
- Integrates up to eight HART field devices (in multidrop mode) into a WirelessHART network
- Can be powered with the 4 to 20 mA loop or an external power supply
- Power management can be activated to minimize energy consumption
- Easy to configure with SIMATIC PDM, AMS, Handheld 475.

Benefits

- "Intrinsically safe" or "Explosion proof"
- High quality and service life
- Extremely rugged enclosure
- No additional cabling required with loop power supply
- Subsequent integration of an installed field device with HART interface into maintenance and diagnostic systems if the control system does not feature the required communication mechanisms
- Proven HART devices can continue to be used for wireless communication without any limitations
- Field devices with a 4 to 20 mA interface (without HART) can also be connected
- Ideal addition to wired communication and to the range of system solutions in process automation
- Burst mode and event notification configuration for the adapter and connected field devices

Application

The WirelessHART adapter can be used in a number of different applications:

- Access to installed basis
Diagnostic information is obtained from existing wired HART devices thanks to the permanent electrical connection of a WirelessHART adapter and power from the 4 to 20 mA loop. This information is sent to central system-based asset management software such as SITRANS MDS.
- Status monitoring of the plant
Wireless devices are mounted at critical points in the plant which are not usually connected to the control room due to difficult access or high wiring costs. Better data flow and diagnostics increase plant reliability, transparency and safety.
- Process optimization
Temporary installation of a 4 to 20mA or standard HART device together with a SITRANS AW210 WirelessHART adapter allows easier, flexible monitoring and plant optimization at lower costs. SITRANS AW210 can also be usefully used where there is already an external power supply, or one is needed anyway.
- Process monitoring
Measured values, for example from tanks or silos, are transmitted to a higher-level system at regular intervals together with the device status. SITRANS AW210 is particularly easy to use with 4-wire devices, as they have an external power supply.

Design

SITRANS AW210 WirelessHART Adapter consists of:

- An enclosure with a fitted aerial
- Electronics

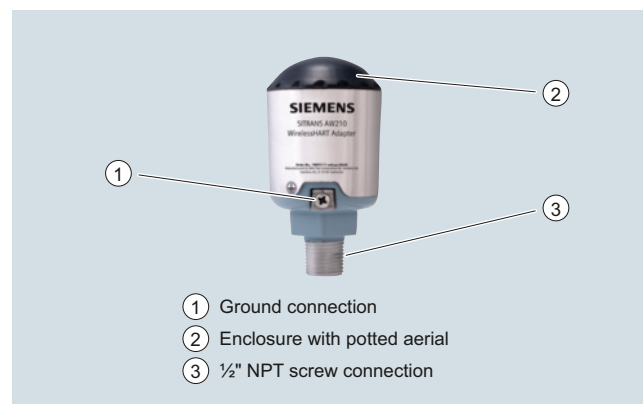

SITRANS AW210 Wireless-HART Adapter, assembly

The enclosure contains the potted electronics and the wireless module. The aerial is fitted at the top in the enclosure.

On the base of the enclosure is the connector with a 1/2" NPT female thread. Six cables run from this connector to connect the adapter.

SITRANS AW210 - WirelessHART adapter

Function

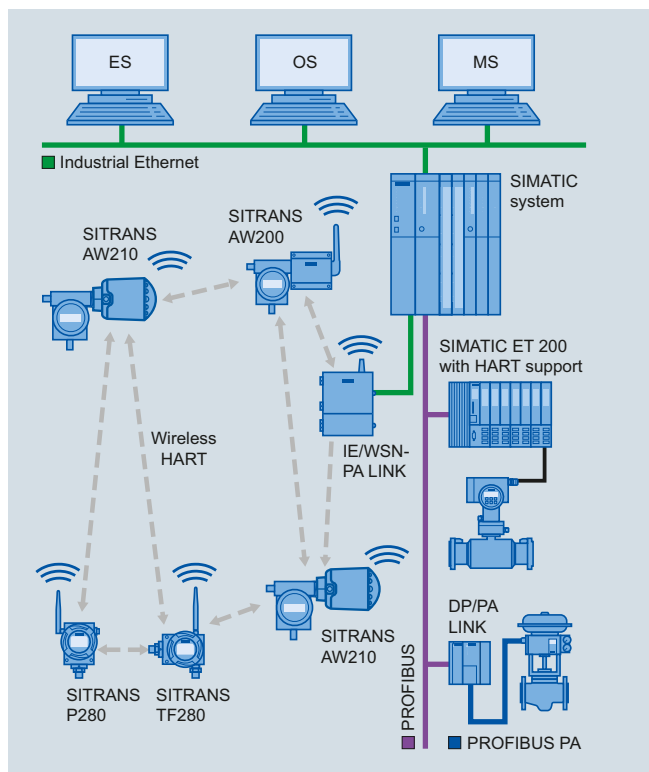

SITRANS AW210 WirelessHART Adapter, functional diagram

The measured values and diagnostic information from the connected field devices with HART communication are transmitted to the WirelessHART adapter over wired connections. The adapter transmits this information as wireless signals to the IE/WSN-PA link, the Siemens WirelessHART gateway. The measured values, all parameters and diagnostic information about the plant network can be accessed from this gateway.

If a field device with a 4 to 20 mA output signal is connected to the adapter, the current will be converted to a digital measured value and transmitted on the basis of a measuring range specified in SITRANS AW210.

Following configuration and integration into a WirelessHART network, each WirelessHART adapter is able to recognize its neighbors. It notes the strength of the wireless signal, synchronizes itself, receives network information and then establishes connections to its neighbors in the wireless network. A WirelessHART network organizes itself. Manual settings for organization are not required.

Two-wire and four-wire field devices can be connected to a WirelessHART adapter. Either up to 2 or up to 8 HART field devices can be connected to the adapter, depending on the selected product version. The adapter either has an external voltage supply or is loop-powered. The WirelessHART adapter can therefore also be connected in parallel to an existing installation consisting of a voltage supply and a HART field device.

Parameter assignment

SITRANS AW210 is configured via HART. Configuration can be carried out using handheld communicator 475 or, more conveniently, with a HART modem and the SIMATIC PDM configuration software.

Initial startup of the adapter is usually carried out via SIMATIC PDM and a HART modem or a handheld communicator. During initial startup, the network ID and join key are set in the adapter. These parameters are used to integrate the adapter into an existing WirelessHART network.

Following integration into the network, the adapter and HART devices connected can be conveniently operated via the WirelessHART network or locally, as detailed above.

Siemens HART field devices for the adapter

In principle, all HART devices certified by the HART Communication Foundation (HCF) can be operated with the SITRANS AW210 WirelessHART adapter. See <http://www.siemens.com/automation/service&support> for FAQ with the latest information on connectivity for Siemens field devices.

Note:

Siemens has only approved the Siemens HART field devices listed there for the adapter, and will only provide technical support for these devices.

Based on HART specifications, it is generally possible to connect devices that are not listed, however with the following restrictions:

- All warranties and liability will be excluded
- No technical support

Technical specifications

Input	Point-to-point connection to a HART field device or Point-to-point connection to a 4 ... 20 mA field device or Up to eight HART field devices with an external voltage supply integrated using multidrop
Communication	<ul style="list-style-type: none"> • HART communication with multidrop, as primary or secondary HART master (can be specified) • 4 ... 20 mA current signal with a point-to-point connection scaling in user-defined measuring range in SITRANS AW210 <ul style="list-style-type: none"> - Linear - User-defined scaling with up to 32 points
Protocol	HART V7 (compatible with previous HART versions)

Supplementary Components

WirelessHART products

SITRANS AW210 - WirelessHART adapter

Output	
Communication	WirelessHART V7
Transmission frequency band	2.4 ... 2.4835 GHz (ISM band), 16-channel frequency hopping spread spectrum
Range (under reference conditions)	Outside up to 235 m (771 ft)
RF signal strength	10 dBm
Output signals	<ul style="list-style-type: none"> • WirelessHART adapter • HART Cmd 3 Measured current and up to 4 other dynamic variables (measured values, derived values) or device variables • HART Cmd 9 Up to 8 dynamic variables with status • HART Cmd 48 Additional status information
• 4 ... 20 mA field device	Scaled or linearized process values
• HART field device	<ul style="list-style-type: none"> • HART Cmd 3 Measured current and up to 4 other dynamic variables (measured values, derived values) or device variables • HART Cmd 9 Up to 8 dynamic variables with status • HART Cmd 48 Additional status information
Update time for output signals	
	You can set the update times separately for the adapter and the connected devices. The possible settings are: <ul style="list-style-type: none"> • 1, 2, 4, 8, 16, 32 s • 1, 2, 5, 10, 30, 60 min (times also depend on the gateway)
Measuring accuracy	
Max. measuring error (4 ... 20 mA circuit)	1 % of measuring range, 40 ... 85 °C (104 ... 185 °F)
Rated conditions	
Location	Outside/inside
Ambient conditions	
• Ambient temperature	-40 ... +85 °C (-40 ... +185 °F) In hazardous areas up to 75 °C (167 °F)
• Storage temperature	-40 ... +85 °C (-40 ... +185 °F)
Electromagnetic compatibility	To EN 301 489-17 and EN 300 328-1
Design	
Weight	0.46 kg (1.01 lb)
Enclosure	
• Material	
- Enclosure	Aluminum alloy, RoHS-compliant polyurethane corrosion-resistant coating
- Cap	Resin
• Cable entry	½" NPT female thread
Degree of protection	IP68
Aerial	Potted in enclosure
Auxiliary power	
Power supply	Loop power 1 ... DC 2.5 V, can be set by user in 0.5 V DC increments
Loop-powered, operating current	DC 3.2 ... 25 mA operating current; overvoltage, surge and reverse polarity protection

Certificates and approvals	
Wireless communication approvals	<ul style="list-style-type: none"> • CE (R&TTE, EMC) • FCC Part 15.247 for wireless applications in the 2.4 GHz transmission frequency band • IC
Explosion protection	
Intrinsic safe "i" gases and vapors	II 1G Ex ia IIC T*; IP68 T* = T5 for Ta = -40 ... +85 °C T* = T6 for Ta = -40 ... +75 °C
Intrinsic safe dust	II 1 D Ex iaD 20 IP68 T95C; Ta = -40 ... +85 °C
Non-sparking (zone 2)	II 3 G Ex nA nC IIC T* Gc; IP68 T* = T5 for Ta = -40 ... +85 °C T* = T6 for Ta = -40 ... +75 °C
Explosion protection to FM for US Intrinsic safe, Non-sparking	IS/I,II,III/1/ABCDEF/G/ T5 Ta = -40 ... +85 °C, T6 Ta = -40 ... +75 °C NI/II/2/ABCD/ T5 Ta = -40 ... +85 °C, T6 Ta = -40 ... +75 °C S/II,III/2/EF/G/ T5 Ta = -40 ... +85 °C, T6 Ta = -40 ... +75 °C I/O/AEx ia/IIC/ T5 Ta = -40 ... +85 °C, T6 Ta = -40 ... +75 °C; 20/AEx iaD/T95°C; Ta = -40 ... 85°C I/2/AEx nA nC/IIC/ T5 Ta = -40 ... +85 °C, T6 Ta = -40 ... +75 °C; IP68
Explosion protection to FM for CA Intrinsic safe, Non-sparking	IS/I,II,III/1/ABCDEF/G/ T5 Ta = -40 ... +85 °C T6 Ta = -40 ... +75 °C; NI/II/2/ABCD/ T5 Ta = -40 ... +85 °C, T6 Ta = -40 ... +75 °C; S/II,III/2/EF/G/ T5 Ta = -40 ... +85 °C, T6 Ta = -40 ... +75 °C; I/O/Ex ia/IIC/ T5 Ta = -40 ... +85 °C, T6 Ta = -40 ... +75 °C; I/2/Ex nA nC/IIC/ T5 Ta = -40 ... +85 °C T6 Ta = -40 ... +75 °C II/1/EF/G Ta = -40 ... +85°C; IP68
Flameproof gases and vapors	II 2 G Ex d IIC T* Gb; IP68 T* = T5 for Ta = -40 ... +85 °C T* = T6 for Ta = -40 ... +75 °C
Protection by enclosure dust	II 2 D Ex tb IIIC T95°C Ta = -40 ... +85°C; IP68
Explosion protection to FM for US Explosionproof, flameproof, gas, dust	XP/I/1/ABCD I/1 AEx d IIC T5, T6 Gb DIP/II,III/1/EF/G 21/AEx tb IIIC T95°C T5 Ta = -40 ... +85°C, T6 Ta = -40 ... +75°C Type 6P, IP68
Explosion protection to FM for CA Explosionproof, flameproof, gas, dust	XP/I/1/ABCD I/1 Ex d IIC T5, T6 Gb DIP/II,III/1/EF/G T5 Ta = -40 ... +85°C, T6 Ta = -40 ... +75°C

Supplementary Components WirelessHART products

SITRANS AW210 - WirelessHART adapter

Selection and ordering data	Article No.
SITRANS AW210 Adapter for WirelessHART communication	7MP3111 - 0-0AA0
WirelessHART-Adapter AW210 with 4 ... 20 mA- or HART interface	
2 devices	1
8 devices	2
Auxiliary Power	A
Loop powered or 24 V DC (external)	
Certificates and approvals	B C
Intrinsically safe gas, vapors and dust (ATEX), Intrinsic Safe (FM)	
Explosionproof gas, vapour and dust (ATEX), Explosionproof (FM)	
Enclosure	0
Aluminum	

Dimensional drawings

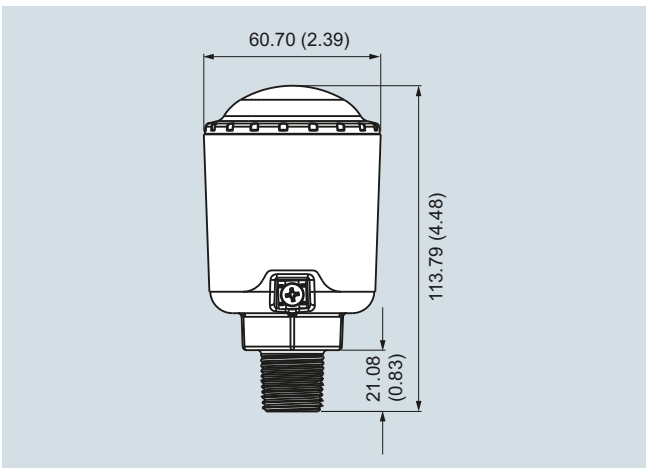

SITRANS AW210 WirelessHART adapter, dimensions in mm (inches)

Schematics

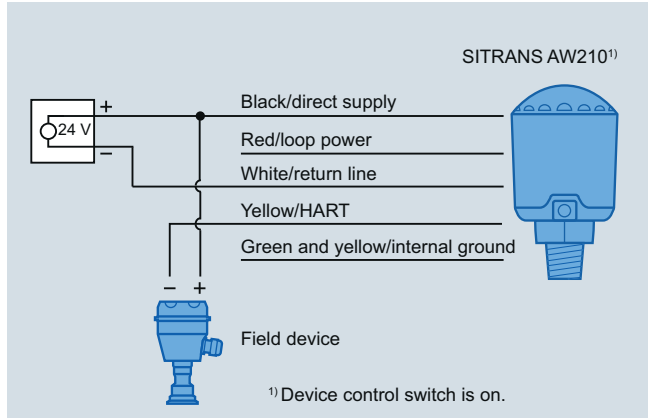

External 24 V DC power supply, connection of one device

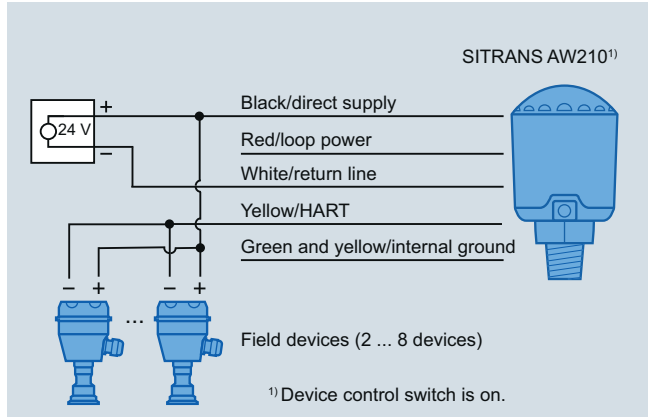

External 24 V DC power supply, connection of multiple devices

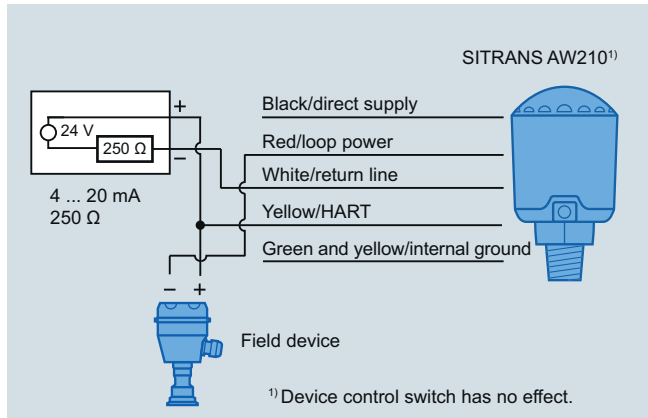

Loop power for connection of one 4 ... 20 mA HART device

Supplementary Components

WirelessHART products

IE/WSN-PA LINK

Overview



- The IE/WSN-PA LINK is a network transition for the connection of WirelessHART field devices (HART V7.1) to Industrial Ethernet, as an alternative or supplement to the wired connection.
- Connection of up to 100 WirelessHART devices
- Approved for operation in hazardous areas in Zone 2
- Open TCP/IP communication and Modbus TCP via the Ethernet interface
- Can be used with HART-OPC servers of the HART Communication Foundation

Note:

A general introduction to WirelessHART and information on the WirelessHART adapter and the WirelessHART field devices can be found in Catalog FI 01 or on the Internet at <http://www.siemens.com/wirelesshart>

Benefits

- Extended possible solutions for connecting process industry field devices by means of alternative or supplementary WirelessHART communication
- Reliable data transmission using intermeshed network technology; the self-organizing network with alternative paths enables radio obstacles to be bypassed
- Reduction of cabling costs under difficult installation conditions, e.g. if the field devices are located on inaccessible plant components or are only required temporarily
- To improve process monitoring and for maintenance tasks, sensors can be retrofitted
- Existing transmitters can be integrated wirelessly into maintenance and diagnostics systems by means of WirelessHART adapters
- Without additional software, restricted monitoring is possible via web services and the integrated web server of the IE/WSN-PA LINK.

Application

The IE/WSN-PA LINK connects wireless HART field devices by radio to the Ethernet. On the radio side, the IE/WSN-PA LINK supports the WirelessHART standard and on the Ethernet side the TCP/IP and Modbus TCP communication.

The IE/WSN-PA LINK thus enables wireless diagnostics, maintenance and process monitoring.

Monitoring

WirelessHART is particularly suitable for use in plant sections that are to be included in monitoring, but which do not have any existing MSR cabling, e.g. external tank stores or other installations where high cabling costs are anticipated. Data for the visualization can be retrieved from the IE/WSN-PA link via Industrial Ethernet or Modbus TCP.

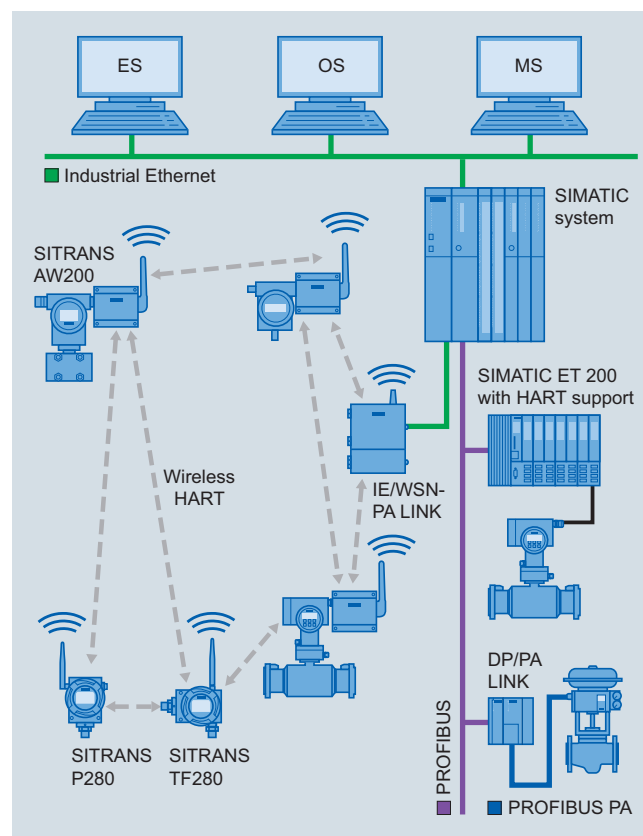

Monitoring of process states via WirelessHART

Retrofitting for diagnostics and maintenance

For this application, wireless adapters are looped into the 4-20 mA interface or screwed directly onto the HART device. The acyclic HART message frames are transmitted by radio between IE/WSN-PA LINK and a wireless adapter. Without affecting the operation of the plant, the wireless adapter modulates the acyclic HART message frames to the 4-20 mA interface or extracts them from the 4-20 mA interface.

The IE/WSN-PA LINK collects the data of all wireless adapters and transfers it via Industrial Ethernet to the diagnostics and maintenance station.

If greater distances between the IE/WSN-PA LINK and the monitoring station are to be spanned without cabling, this can be implemented by means of Industrial Wireless LAN with the access points and client modules of the SCALANCE W family.

Supplementary Components WirelessHART products

IE/WSN-PA LINK

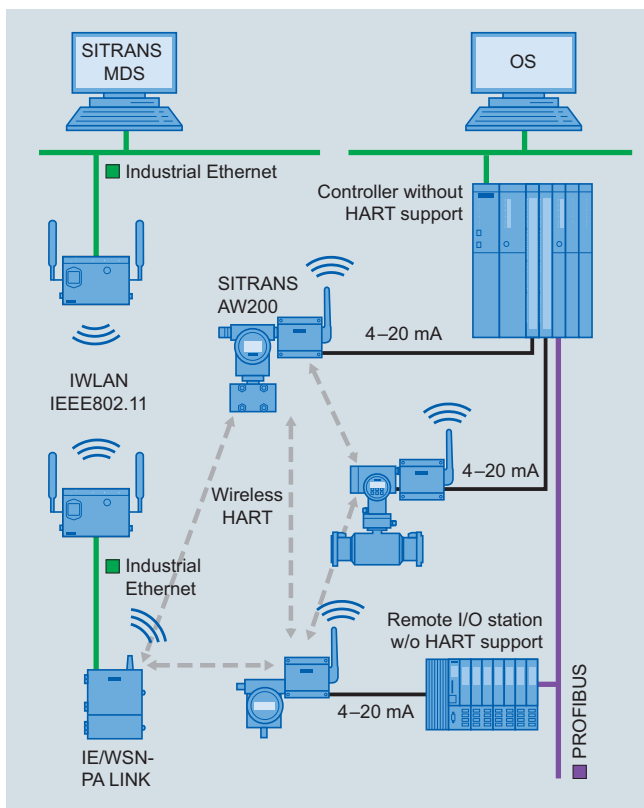

Retrofitting of plants for diagnostics and maintenance

Design

- 2 x 10/100/1 000 Mbit/s RJ45 ports, electrical (no integral switch; interfaces can be used, for example, for continuous connection to the plant network as well as the temporary connection of a PC)
- 1 x screw terminal for connection to Modbus RTU via RS 485
- 1 x screw terminal for the 24 V DC connection
- Rugged metal enclosure with IP65 protection for use outdoors, also in hazardous zone 2
- Mounting: wall or mast mounting (vertical); U-bolts for mast mounting are included in the scope of delivery.

Product versions

- With integral, non-detachable antenna
- Redundancy function and with N connector for connection of an external antenna

Function

WirelessHART

The IE/WSN-PA LINK establishes on the radio side an intermeshed wireless sensor network for communication with wireless field devices (e.g. transmitters). The data from the wireless field devices is received by the IE/WSN-PA LINK and transmitted via Industrial Ethernet to the connected systems. The supported wireless network is an open wireless network specified by the HART Communication Foundation (HCF) in accordance with the WirelessHART (HART V7.1) standard.

On the field device side, the IE/WSN-PA LINK requires field devices that support WirelessHART (HART). Existing field devices can be integrated by means of wireless adapters into the WirelessHART communication. To this end, the adapters are looped into the 4-20 mA interface. In addition, as many as four standard HART field devices with external power supply can be connected to the adapter in multidrop mode. Individually connected devices can be operated with the battery of the adapter.

The adapter wirelessly transmits all data and process values of the connected devices. The advantage of this solution is that tried and tested devices can continue to be used.

Industrial Ethernet

Via the Ethernet interface the IE/WSN-PA LINK supports the use of the HART OPC server and the Modbus TCP protocol.

Configuration

The configuration is web-based, without additional software, and performed from the PC. By means of the web user interface it is also possible to display the device states and measured values of the WirelessHART devices.

Increased availability of WirelessHART application due to redundancy mode

For increased availability requirements, the link can be used redundantly. The redundancy function is only available for the device variant with a connection for an external antenna.

Two links are connected to the same Ethernet subnet via a switch to provide the redundancy. The two links are connected to each other via an Ethernet cable (management coupling). One of the two links is configured as the active device. It carries out the communication between the control center and the WirelessHART wireless network under normal conditions. The second link is configured identically. It is used as a standby device. In a redundancy scenario, the standby device becomes the active device.

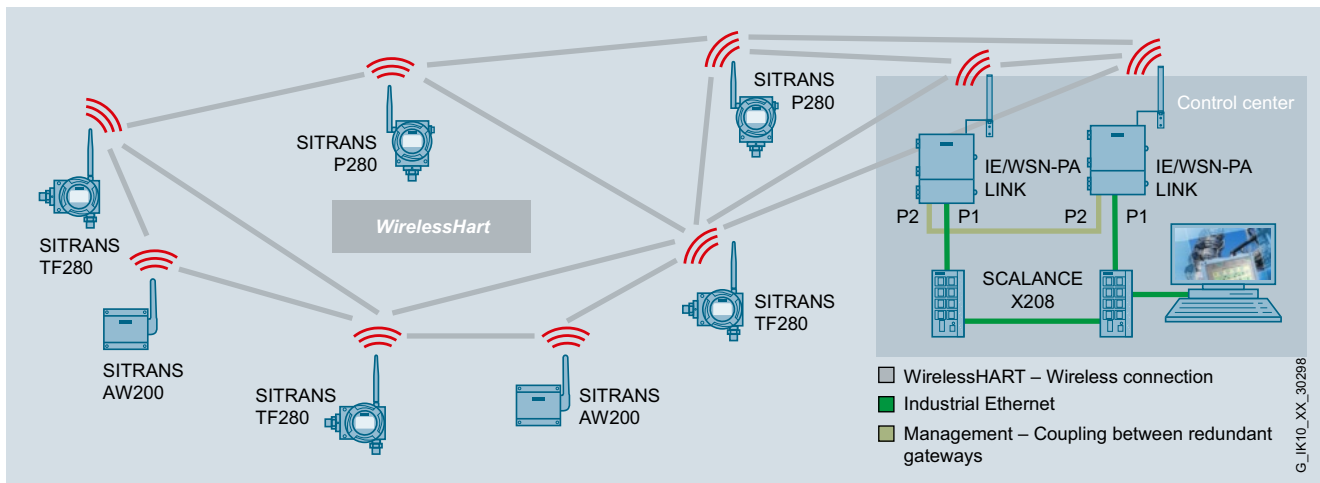

WirelessHART network operated with a redundant gateway

7

Supplementary Components

WirelessHART products

IE/WSN-PA LINK

Integration

Integration into automation systems

The IE/WSN-PA LINK can be integrated into automation systems via Ethernet or Modbus TCP. Communication modules (CP 343-1 or CP 443-1) are required to connect the IE/WSN-PA LINK to SIMATIC S7-300/400. Function blocks and technical support can be found at:

www.siemens.com/simatic-net/ik-info

Integration in PCS 7

For integration of the IE/WSN-PA LINK into PCS 7 you can obtain function blocks and technical support at:

www.siemens.com/simatic-net/ik-info

Technical specifications

Article No.	6GK1 411-6CA40-0AA0	6GK1 411-6CA40-0BA0
Product type designation	IE/WSN-PA LINK	IE/WSN-PA LINK
Data transmission rate		
• at interface 1	10 ... 100 Mbit/s	
• at interface 2	10 ... 100 Mbit/s	
• at interface 3	9.6 to 57.6 kbps	
Interfaces		
Number of electrical connections		
• at interface 1 in accordance with Industrial Ethernet	1	
• at interface 2 in accordance with Industrial Ethernet	1	
• at interface 3 in accordance with RS 485	1	
• For power supply	1	
Design of electrical connection		
• at interface 1 in accordance with Industrial Ethernet	RJ45 port	
• at interface 2 in accordance with Industrial Ethernet	RJ45 port	
• at interface 3 in accordance with RS 485	2-pin terminal strip	
• For power supply	3-pin terminal strip	
Interfaces Wireless		
Number of radio cards permanently installed	1	1
Number of internal antennas	1	0
Number of electrical connections for external antenna(s)	0	1
Design of electrical connection for external antenna(s)	-	N-Connector
Supply voltage, current consumption, power loss		
Type of power supply	DC	
Supply voltage, external	24 V	
• Minimum	20 V	
• Maximum	28 V	
Current consumed from external power supply at 24 V DC, maximum	0.5 A	
Active power loss, maximum	12 W	
Permitted ambient conditions		
Ambient temperature		
• During operating	-40 ... +70 °C	
• During storage	-40 ... +85 °C	
• During transport	-40 ... +85 °C	
Relative humidity at 25 °C without condensation during operating phase, maximum	90 %	
Protection class IP	IP 65	
Design, dimensions and weights		
Width of the housing	229 mm	
Height of the housing		
• Without antenna	306 mm	
• With antenna	354 mm	
Depth of the housing	89 mm	
Net weight	4.54 kg	
Type of mounting		
• Wall mounting	Yes	
• Mast mounting	Yes	
Type of mounting	Material for mast mounting included in scope of delivery	

Supplementary Components

WirelessHART products

IE/WSN-PA LINK

Wireless frequencies	
Radio frequency with WirelessHART in the 2.4 GHz frequency band	
• Initial value	2.4 GHz
• End value	2.5 GHz
Performance data	
WirelessHART	
Number of WirelessHART devices which can be operated	100
Network latency	
• For 100 field devices and WirelessHART network maximum	10 s
• For 50 field devices and WirelessHART network maximum	5 s
Transition link between two devices with WirelessHART network	
• Maximum	100 m
• Note	The values may deviate if obstacles affecting radio transmission are present
Protocol will be supported HART	Yes
Product properties, functions, components General	
Protocol is supported	
• Address Resolution Protocol (ARP)	Yes
• HTTP	Yes
• HTTPS	Yes
• Modbus TCP	Yes
• Modbus TCP secure	Yes
• Modbus RTU	Yes
Product functions Management, configuration	
Product function	
• Web-based management	Yes
• DHCP client	Yes
Product functions Diagnosis	
Product function	
• Web-based diagnostics	Yes
• WirelessHART diagnostics via Modbus	Yes
Product functions Redundancy	
Product function device redundancy	No Yes
Product functions Security	
Product function	
• Password protection - multilevel	Yes
• WirelessHART join key	Yes
• ACL - MAC-based	Yes
• WirelessHART network ID	Yes
SSL protocol is supported	Yes
Encryption principle	AES 128 bit
Product functions Time	
NTP protocol is supported	Yes

Standards, specifications, approvals

Standard for WirelessHART	HART V 7.1
Standard for wireless communication IEEE 802.15.4	Yes
Certificate of suitability	
• CE mark	Yes
• Referred to CSA	CSA Division 2 & Dust Ignition-proof for Class I, Division 2, Groups A, B, C, and D. Dust Ignition-proof for Class II, Groups E, F, and G / Suitable for Class III Hazardous Locations. / Install per Siemens drawing A5E02467236A. Temperature Code: T4 (-40°C < Ta < 60°C) CSA Enclosure Type 4X
• Referred to FM	FM Division 2, Non-Incendive for Class I, Division 2, Groups A, B, C, and D. Dust Ignition-proof for Class II, III, Division 1, Groups E, F, and G / Indoor and outdoor locations / NEMA Type 4X Temperature Code: T4 (-40°C < Ta < 60°C)
• Referred to ATEX	ATEX type n, see note: Certificate number: Baseefa10ATEX0044X, ATEX marking: Ex II 3 G, Ex nA nL IIC T4 (-40 °C ≤ Ta ≤ 60 °C), rated voltage: 28 V, ATEX Dust Ignition-proof: Certificate number: Baseefa10ATEX0045X, ATEX marking: II 3 D, Ex tD A22 IP66 T135 (-40 °C ≤ Ta ≤ 60 °C), rated voltage: 28 V. Note on type n: Conditions for safe handling during installation: The device does not pass the 500 V insulation test in accordance with paragraph 6.8.1 of EN 60079-15:2005. This must be taken into account when installing the device.
• Referred to IECEx	IECEx type n, see note: Certificate number: IECEx BAS 10.0014X, Ex nA nL IIC T4 (-40 °C ≤ Ta ≤ 60 °C), rated voltage: 28 V, IECEx Dust Ignition-proof, see note: Certificate number: IECEx BAS 10.0015X, Ex tD A22 IP66 T135 (-40 °C ≤ Ta ≤ 60 °C), rated voltage: 28 V. Note on type n: Conditions for safe handling during installation: The device does not pass the 500 V insulation test in accordance with paragraph 6.8.1 of EN 60079-15:2005. This must be taken into account when installing the device.
Referred to NEMA	-
Wireless approval	FCC and IC approval IC approval

7

Supplementary Components

WirelessHART products

IE/WSN-PA LINK

Selection and Ordering data

	Article No.		Article No.
IE/WSN-PA LINK Gateway between WirelessHART and Industrial Ethernet; transmission frequency: 2.4 GHz <ul style="list-style-type: none"> • With integral, non-detachable antenna • N connector for connection of external antennas 	6GK1411-6CA40-0AA0 6GK1411-6CA40-0BA0	IE FC Stripping Tool Preadjusted stripping tool for fast stripping of the Industrial Ethernet FC cables	6GK1901-1GA00
Antennas Antennas with omni-directional characteristics; country permits, compact instructions (hard copy), German/English <u>Wall or mast-mounting</u> <ul style="list-style-type: none"> • Antenna ANT792-6MN Antenna gain including N-Connect connector 6 dBi, 2.4 GHz 	6GK5792-6MN00-0AA6	Network components for IWLAN HARTING adapter cable ¹⁾ M12 female NPT 1/2 thread to RJ45 11cm, (minimum order quantity: 10); The adapter is provided for easy connection of the link to the Industrial Ethernet;	see "Industrial Wireless Communication" 21036836420 Not included in the scope of delivery of the IE/WSN-PA link; You can find ordering information on the Internet at: http://www.harting.de/kontakt/adressen/
<u>Roof mounting</u> <ul style="list-style-type: none"> • ANT795-6MN antenna Antenna gain incl. N-Connect connector 6/8 dBi, 2.4/5 GHz • Antenna mounting tool (ANT795-6MN) Mounting tool for installation of ANT795-6MN under a roof 	6GK5 795-6MN00-0AA6 6GK5 795-6MN01-0AA6	SITOP compact 24 V/ 0.6 A 1-phase power supply with wide-range input 85 – 264 V AC/110 – 300 V DC, stabilized output voltage 24 V, rated output current value 0.6 A, slim design	6EP1331-5BA00
LP798-1N Lightning Protector Lightning protector with N/N female/female connector, IP65 (-40 ... +100 °C)	6GK5798-2LP00-2AA6	¹⁾ When using the Harting adapter cable for the Ethernet connection, the requirements for intrinsic safety approval are not applicable. When used in an application relevant to intrinsic safety guidelines, it requires acceptance by the appropriate approval agency.	
Antenna cables IWLAN N-Connect male/male flexible connection cable Flexible connecting cable for connecting an external antenna; assembled with two N-Connect male connectors <ul style="list-style-type: none"> • 1 m • 2 m • 5 m • 10 m 	6XV1875-5AH10 6XV1875-5AH20 6XV1875-5AH50 6XV1875-5AN10		
HF coupling N-Connect male/male connector for connecting the LP798-1N lightning protector	6GK5798-0CP00-1AA0		
Accessories IE FC M12 Plug PRO M12 plug-in connector suitable for on-site assembly (D-coded, IP65/IP67), metal housing, Fast-Connect connection system, for connecting HARTING adapter cables to the Industrial Ethernet <ul style="list-style-type: none"> • 1 unit 	6GK1 901-0DB20-6AA0		
IE FC TP Standard Cable GP 2 x 2 (Type A) 4-core, shielded TP installation cable for connection to IE FC Outlet RJ45/IE FC RJ45 Plug; PROFINET-compatible; with UL approval; sold by the meter; max. length 1000 m, minimum order quantity 20 m	6XV1 840-2AH10		

More information

Current approvals can be found on the Internet at:

<http://support.automation.siemens.com/WW/view/en/46374734>