

# SIEMENS

## SIMATIC NET

### Industrial Ethernet switches SCALANCE X-100

#### Operating Instructions

<u>Introduction</u>	<b>1</b>
<u>Network topologies</u>	<b>2</b>
<u>Description of the device</u>	<b>3</b>
<u>Assembly</u>	<b>4</b>
<u>Connecting up</u>	<b>5</b>
<u>Maintenance and troubleshooting</u>	<b>6</b>
<u>Technical specifications</u>	<b>7</b>
<u>Certifications and approvals</u>	<b>8</b>
<u>Dimension drawings</u>	<b>9</b>

## Legal information

### Warning notice system

This manual contains notices you have to observe in order to ensure your personal safety, as well as to prevent damage to property. The notices referring to your personal safety are highlighted in the manual by a safety alert symbol, notices referring only to property damage have no safety alert symbol. These notices shown below are graded according to the degree of danger.

#### **DANGER**

indicates that death or severe personal injury **will** result if proper precautions are not taken.

#### **WARNING**

indicates that death or severe personal injury **may** result if proper precautions are not taken.

#### **CAUTION**

indicates that minor personal injury can result if proper precautions are not taken.

#### **NOTICE**

indicates that property damage can result if proper precautions are not taken.

If more than one degree of danger is present, the warning notice representing the highest degree of danger will be used. A notice warning of injury to persons with a safety alert symbol may also include a warning relating to property damage.

### Qualified Personnel

The product/system described in this documentation may be operated only by **personnel qualified** for the specific task in accordance with the relevant documentation, in particular its warning notices and safety instructions. Qualified personnel are those who, based on their training and experience, are capable of identifying risks and avoiding potential hazards when working with these products/systems.

### Proper use of Siemens products

Note the following:

#### **WARNING**

Siemens products may only be used for the applications described in the catalog and in the relevant technical documentation. If products and components from other manufacturers are used, these must be recommended or approved by Siemens. Proper transport, storage, installation, assembly, commissioning, operation and maintenance are required to ensure that the products operate safely and without any problems. The permissible ambient conditions must be complied with. The information in the relevant documentation must be observed.

### Trademarks

All names identified by ® are registered trademarks of Siemens AG. The remaining trademarks in this publication may be trademarks whose use by third parties for their own purposes could violate the rights of the owner.

### Disclaimer of Liability

We have reviewed the contents of this publication to ensure consistency with the hardware and software described. Since variance cannot be precluded entirely, we cannot guarantee full consistency. However, the information in this publication is reviewed regularly and any necessary corrections are included in subsequent editions.

# Table of contents

<b>1</b>	<b>Introduction</b> .....	<b>5</b>
1.1	On the Operating Instructions.....	5
1.2	On the product .....	7
<b>2</b>	<b>Network topologies</b> .....	<b>11</b>
<b>3</b>	<b>Description of the device</b> .....	<b>13</b>
3.1	Overview of the SCALANCE X-100.....	13
3.2	Product properties.....	14
3.2.1	SCALANCE X104-2.....	14
3.2.2	SCALANCE X106-1 .....	15
3.2.3	SCALANCE X108 .....	16
3.2.4	SCALANCE X108PoE .....	17
3.2.5	SCALANCE X112-2.....	18
3.2.6	SCALANCE X116 .....	19
3.2.7	SCALANCE X124 .....	20
3.3	TP ports (twisted pair).....	20
3.4	FO port (fiber optic).....	23
3.5	LED display .....	24
3.6	SET button .....	25
<b>4</b>	<b>Assembly</b> .....	<b>27</b>
4.1	Safety notices for installation .....	27
4.2	Types of installation .....	29
4.3	Installation on a DIN rail.....	29
4.4	Installation on a standard rail.....	31
4.5	Wall mounting .....	33
<b>5</b>	<b>Connecting up</b> .....	<b>35</b>
5.1	Safety when connecting up.....	35
5.2	Power supply .....	37
5.3	Signaling contact.....	38
5.4	Grounding .....	39
5.5	IE FC RJ-45 Plug 180 .....	39
<b>6</b>	<b>Maintenance and troubleshooting</b> .....	<b>41</b>
6.1	Possible sources of problems and how to deal with them.....	41

<b>7</b>	<b>Technical specifications .....</b>	<b>43</b>
7.1	SCALANCE X104-2 .....	43
7.2	SCALANCE X106-1 .....	45
7.3	SCALANCE X108 .....	48
7.4	SCALANCE X108PoE .....	50
7.5	SCALANCE X112-2 .....	52
7.6	SCALANCE X116 .....	54
7.7	SCALANCE X124 .....	56
7.8	Mechanical stability (in operation).....	59
<b>8</b>	<b>Certifications and approvals .....</b>	<b>61</b>
8.1	EU declaration of conformity.....	62
8.1.1	ATEX.....	63
8.1.2	EMC .....	64
8.1.3	RoHS.....	64
8.1.4	Products .....	65
8.2	ATEX (KEMA 07 ATEX0145 X) .....	65
<b>9</b>	<b>Dimension drawings.....</b>	<b>69</b>
	<b>Index .....</b>	<b>75</b>

# Introduction

## 1.1 On the Operating Instructions

### Purpose of the Operating Instructions

These Operating Instructions support you when commissioning networks with the Industrial Ethernet switches of the SCALANCE X-100 product line.

### Validity of the Operating Instructions

These operating instructions are valid for the following devices:

Device	Order number
SCALANCE X104-2	6GK5 104-2BB00-2AA3
SCALANCE X106-1	6GK5 106-1BB00-2AA3
SCALANCE X108	6GK5 108-0BA00-2AA3
SCALANCE X108PoE	6GK5 108-0PA00-2AA3
SCALANCE X112-2	6GK5 112-2BB00-2AA3
SCALANCE X116	6GK5 116-0BA00-2AA3
SCALANCE X124	6GK5 124-0BA00-2AA3

### Further documentation

The "SIMATIC NET Industrial Ethernet Twisted Pair and Fiber Optic Networks" manual contains additional information on other SIMATIC NET products that you can operate along with the IE switches of the SCALANCE XB-000 product line in an Industrial Ethernet network.

You can order the manual "SIMATIC NET Industrial Twisted Pair and Fiber Optic Networks", release 05/2001, using the following order numbers:

6GK1970-1BA10-0AA0 German  
 6GK1970-1BA10-0AA1 English  
 6GK1970-1BA10-0AA2 French  
 6GK1970-1BA10-0AA4 Italian

You will also find this network manual on the Internet pages of Service & Support under the following entry ID: 1172207 (<http://support.automation.siemens.com/WW/view/en/1172207>).

You will find further information in the "System Manual Industrial Ethernet" in the Manual Collection.

You will find further information on the SCALANCE system on the Internet at [www.siemens.com/scalance](http://www.siemens.com/scalance) ([www.siemens.com/scalance](http://www.siemens.com/scalance)).

You can obtain the "PROFINET Installation Guide" from the PROFIBUS User Organization (PNO).

## Audience

These Operating Instructions are intended for persons who commission networks with the IE switches of the SCALANCE X-100 product line.

## SIMATIC NET glossary

Explanations of many of the specialist terms used in this documentation can be found in the SIMATIC NET glossary.

You will find the SIMATIC NET glossary on the Internet at the following address:

50305045 (<http://support.automation.siemens.com/WW/view/en/50305045>)

## Security information

Siemens provides products and solutions with industrial security functions that support the secure operation of plants, systems, machines and networks.

In order to protect plants, systems, machines and networks against cyber threats, it is necessary to implement – and continuously maintain – a holistic, state-of-the-art industrial security concept. Siemens' products and solutions only form one element of such a concept.

Customer is responsible to prevent unauthorized access to its plants, systems, machines and networks. Systems, machines and components should only be connected to the enterprise network or the internet if and to the extent necessary and with appropriate security measures (e.g. use of firewalls and network segmentation) in place.

Additionally, Siemens' guidance on appropriate security measures should be taken into account. For more information about industrial security, please visit <http://www.siemens.com/industrialsecurity> (<http://www.siemens.com/industrialsecurity>)

Siemens' products and solutions undergo continuous development to make them more secure. Siemens strongly recommends to apply product updates as soon as available and to always use the latest product versions. Use of product versions that are no longer supported, and failure to apply latest updates may increase customer's exposure to cyber threats.

To stay informed about product updates, subscribe to the Siemens Industrial Security RSS Feed under

<https://support.industry.siemens.com/cs/ww/en/ps/15247/pm>  
(<https://support.industry.siemens.com/cs/ww/en/ps/15247/pm>).

## 1.2 On the product

### What is possible?

The devices of the SCALANCE X100 product line allow the cost-effective installation of Industrial Ethernet bus and star structures with switching functionality.

With the following IE switches, there are also electrical/optical media transitions:

- SCALANCE X104-2
- SCALANCE X106-1
- SCALANCE X112-2

IE switches with the suffix PoE also allow the supply of power to end devices over Ethernet cables with Power-over-Ethernet complying with 802.3af.

---

#### Note

If devices are supplied over long 24 V power supply lines or networks, measures are necessary to prevent interference by strong electromagnetic pulses on the supply lines. These can result, for example, due to lightning or switching of large inductive loads.

One of the tests used to attest the immunity of these devices to electromagnetic interference is the "surge immunity test" according to EN 61000-4-5. This test requires overvoltage protection for the power supply lines. A suitable device is, for example, the Dehn Blitzductor BVT AVD 24 V type no. 918 422 or a comparable protective element.

Manufacturer:

DEHN+SÖHNE GmbH+Co.KG Hans Dehn Str.1 Postfach 1640 D-92306 Neumarkt, Germany

---

 <b>WARNING</b>
----------------------------------------------------------------------------------------------------

When used in hazardous environments corresponding to Class I, Division 2 or Class I, Zone 2, the device must be installed in a cabinet or a suitable enclosure.
-----------------------------------------------------------------------------------------------------------------------------------------------------------------

 <b>WARNING</b>
----------------------------------------------------------------------------------------------------

To comply with EU Directive 94/9 (ATEX95), this enclosure must meet the requirements of at least IP54 in compliance with EN 60529.
------------------------------------------------------------------------------------------------------------------------------------

 <b>WARNING</b>
----------------------------------------------------------------------------------------------------

<b>EXPLOSION HAZARD</b>
-------------------------

DO NOT CONNECT OR DISCONNECT EQUIPMENT WHEN A FLAMMABLE OR COMBUSTIBLE ATMOSPHERE IS PRESENT.
-----------------------------------------------------------------------------------------------

## Components of the product

The following components are supplied with a SCALANCE X-100:

- IE Switch SCALANCE X-100
- 2-pin plug-in terminal block (signaling contact)
- 4-pin plug-in terminal block (power supply)
- Product information

## Accessories

Component	Packaging unit	Order number
IE FC Stripping Tool	1	6GK1901-1GA00
IE FC blade cassettes (5 mm)	1	6GK1901-1GB01
IE FC TP standard cable GP	1	6XV1840-2AH10
IE FC TP trailing cable	1	6XV1840-3AH10
IE FC TP marine cable	1	6XV1840-4AH10
IE FC TP trailing cable GP	1	6XV1870-2D
IE FC TP flexible cable GP	1	6XV1870-2B
IE FC TP FRNC cable GP	1	6XV1871-2F
IE FC TP festoon cable GP	1	6XV1871-2S
IE FC TP food cable	1	6XV1871-2L
IE TP torsion cable	1	6XV1870-2F
FO standard cable GP (50/125)	1	6XV1873-2A
FO trailing cable (50/125)	1	6XV1873-2C
FO trailing cable GP (50/125)	1	6XV1873-2D
FO ground cable (50/125)	1	6XV1873-2G
FO FRNC cable (50/125)	1	6XV1873-2B
IE FC RJ-45 Plug 180	1	6GK1901-1BB10-2AA0
IE FC RJ-45 Plug 180	10	6GK1901-1BB10-2AB0
IE FC RJ-45 Plug 180	50	6GK1901-1BB10-2AE0



## Unpacking and checking

 **WARNING****Do not use any parts that show evidence of damage**

If you use damaged parts, there is no guarantee that the device will function according to the specification.

If you use damaged parts, this can lead to the following problems:

- Injury to persons
- Loss of the approvals
- Violation of the EMC regulations
- Damage to the device and other components

Use only undamaged parts.

1. Make sure that the package is complete.
2. Check all the parts for transport damage.

## Electrostatic discharge

**NOTICE****Electrostatic sensitive devices (ESD)**

Electronic modules contain electrostatic sensitive components

These components can easily be destroyed if handled incorrectly.

Note the following instructions to avoid damage.

- Touch electronic modules only when you absolutely need to work on them.
- If electronic modules need to be touched, the body of the person involved must first be electrostatically discharged and grounded.
- Do not bring electronic modules in contact with electrically isolating materials such as plastic film, isolating table top pads or clothing made of synthetic fibers.
- Place the modules only on conductive surfaces.
- Pack, store and transport electronic modules and components only in conductive packaging such as metalized plastic or metal containers, conductive foam or household aluminum foil.



## Network topologies

Switching technology allows extensive networks to be set up with numerous nodes and simplifies network expansion.

### Which topologies can be implemented?

Using the IE switches of the SCALANCE X-100 product line, you can implement star topologies.

---

#### Note

Keep to the maximum permitted cable lengths of the devices you are using. You will find the permitted cable lengths in the section "Technical specifications (Page 43)".

---

### Star topology

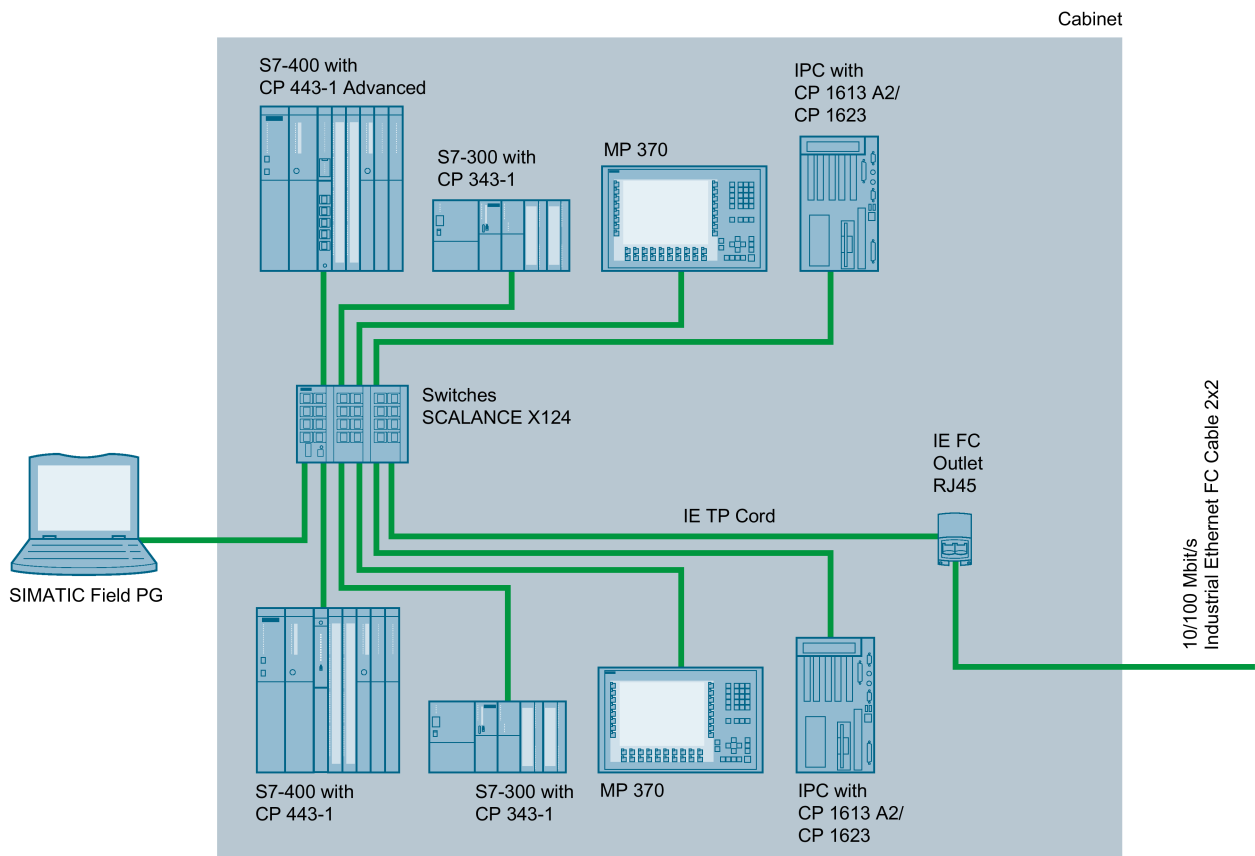

Figure 2-1 Example of an electrical star topology with SCALANCE X124

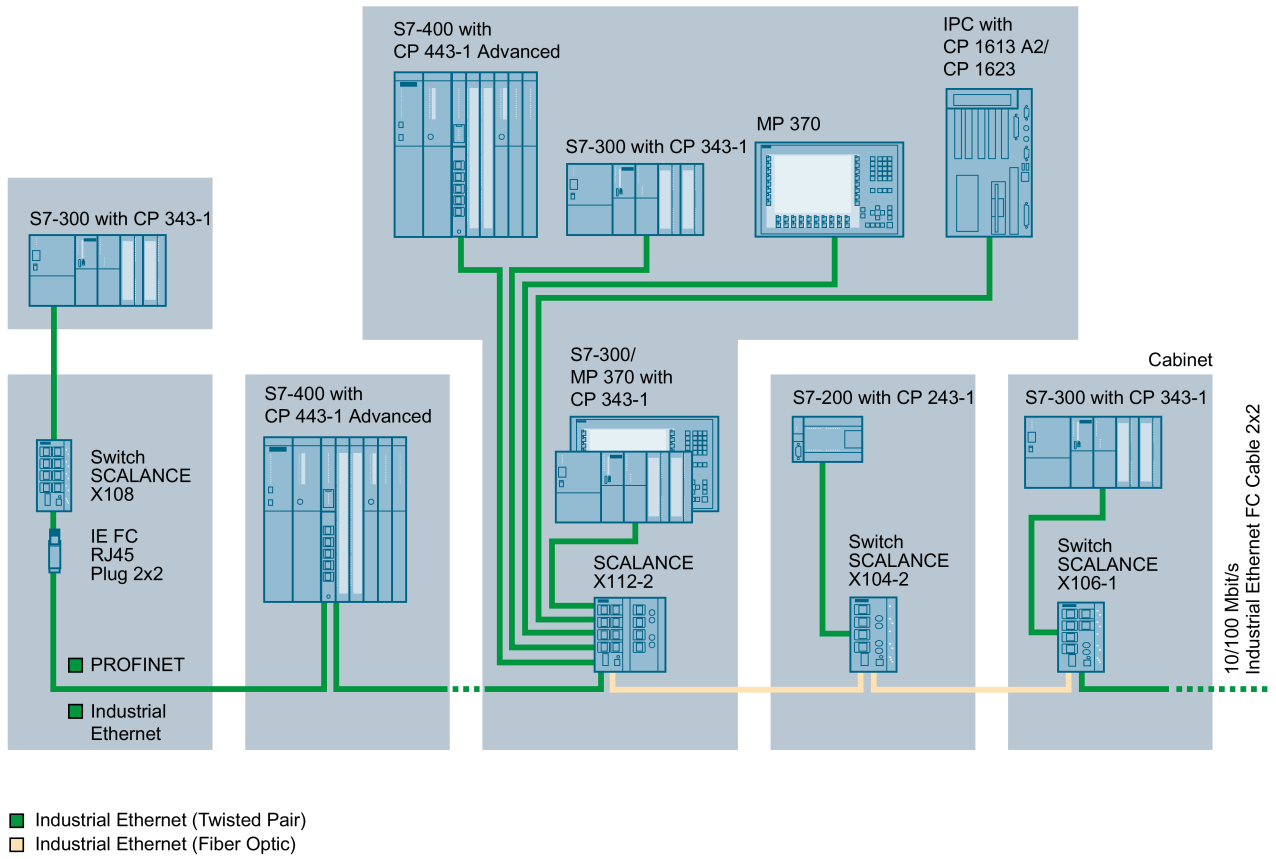

Figure 2-2 Example of an electrical/optical star topology with SCALANCE X112-2 and SCALANCE X104-2

## Description of the device

### 3.1 Overview of the SCALANCE X-100

Table 3- 1 Overview of the product characteristics

Device type SCALANCE							
	X104-2	X106-1	X108	X108PoE	X112-2	X116	X124
SIMATIC environment	+	+	+	+	+	+	+
Diagnostics LED	+	+	+	+	+	+	+
24 VDC	+	+	+	+	+	+	+
2 x 24 VDC	+	+	+	+	+	+	+
Compact housing (securing collar, etc.)	+	+	+	+	+	+	+
Signaling contact + on-site operation	+	+	+	+	+	+	+
Diagnostics: Web, SNMP, PROFINET	-	-	-	-	-	-	-
C-PLUG	-	-	-	-	-	-	-
Ring redundancy with RM	-	-	-	-	-	-	-
Passive ring redundancy	-	-	-	-	-	-	-
Standby redundancy	-	-	-	-	-	-	-
IRT capability	-	-	-	-	-	-	-
Fast learning	-	-	-	-	-	-	-
Passive listening	-	-	-	-	-	-	-
Log table	-	-	-	-	-	-	-
SNTP + SICLOCK	-	-	-	-	-	-	-
Cut Through	-	-	-	-	-	-	-
Number of PoE ports	-	-	-	2	-	-	-

Fast learning:  
Fast recognition of MAC addresses on the device that change during operation (for example, when an end node is reconnected).

Table 3- 2 Overview of the connection options

Device type SCALANCE							
	X104-2	X106-1	X108	X108PoE	X112-2	X116	X124
TP (RJ-45) Fast Ethernet 10 / 100 Mbps	4	6	8	8	12	16	24
Fiber multimode (BFOC) Fast Ethernet 100 Mbps	2	1	-	-	2	-	-

## 3.2 Product properties

### 3.2.1 SCALANCE X104-2

#### Possible connections

The SCALANCE X104-2 has four RJ-45 jacks and two BFOC sockets for the connection of end devices or other network segments.

---

#### Note

The BFOC socket (Bayonet Fiber Optic Connector) corresponds to the ST socket.

---



Figure 3-1 SCALANCE X104-2

### 3.2.2 SCALANCE X106-1

#### Possible connections

The SCALANCE X106-1 has six RJ-45 jacks and a BFOC socket for the connection of end devices or other network segments.

---

#### Note

The BFOC socket (Bayonet Fiber Optic Connector) corresponds to the ST socket.

---



Figure 3-2 SCALANCE X106-1

### 3.2.3 SCALANCE X108

#### Possible connections

The SCALANCE X108 has eight RJ-45 jacks for the connection of end devices or other network segments.



Figure 3-3 SCALANCE X108



### 3.2.4 SCALANCE X108PoE

#### Possible connections

The SCALANCE X108 PoE has eight RJ-45 jacks for the connection of end devices or other network segments. Ports 1 and 2 have the PoE function.



Figure 3-4 SCALANCE X108PoE

#### Power over Ethernet (PoE) function

The PoE function allows the power supply of connected Ethernet devices via the Ethernet cable so that the end device does not need a separate power supply.

Per PoE port of the PSE (Power Sourcing Equipment), a maximum of 15.4 W power are available according to the 802.3af standard.

---

#### Note

With a 100 m long cable connected, the end device then has a maximum of 12.95 W available.

---

You will find more information on the PoE function in the section "TP ports (Page 20)".

### 3.2.5 SCALANCE X112-2

#### Possible connections

The SCALANCE X112-2 has twelve RJ-45 jacks and two BFOC sockets for the connection of end devices or other network segments.

---

#### Note

The BFOC socket (Bayonet Fiber Optic Connector) corresponds to the ST socket.

---



Figure 3-5 SCALANCE X112-2

### 3.2.6 SCALANCE X116

#### Possible connections

The SCALANCE X116 has 16 RJ-45 jacks for the connection of end devices or other network segments.



Figure 3-6 SCALANCE X116

### 3.2.7 SCALANCE X124

#### Possible connections

The SCALANCE X124 has 24 RJ-45 jacks for the connection of end devices or other network segments.



Figure 3-7 SCALANCE X124

### 3.3 TP ports (twisted pair)

#### Note

##### Strain relief of the interfaces

To prevent weights or mechanical movement that can affect an interface causing interrupted contact, fix the cables to a cable guide or rail at short intervals.

## RJ-45 connector pinout

With SCALANCE X-100, the twisted-pair port is designed as an RJ-45 jack with MDI-X pin assignment (Medium Dependent Interface Autocrossover) of a network component.

### Special features of the SCALANCE X108PoE

Over and above the pure Ethernet functionality, ports 1 and 2 of the SCALANCE X108PoE can also be used to supply power to Power-over-Ethernet end devices (for example SCALANCE-W) in compliance with 802.3af.

The two ports providing PoE are supplied from the same power source. This means that they are electrically interconnected. They are however isolated from ground, from the ports that do not provide PoE and from the power connector (24 V). Their use is therefore subject to the conditions listed in IEEE 802.3af for Environment A.

The ports that do not provide PoE are all isolated from each other.

Ports 3 to 8 do not have the PoE function.

To supply PoE end devices, 4 or 8-wire connecting cables can be used (according to IEEE 802.3).

---

### Note

Ethernet devices without PoE functionality can also be connected to ports 1 and 2. A voltage is applied only after the SCALANCE X108 PoE has detected a PoE end device complying with the standard at the port.

---

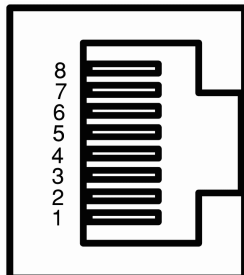

Pin number	Assignment	Additional pins P1, P2 of the SCALANCE X108PoE
Pin 8	n. c.	-
Pin 7	n. c.	-
Pin 6	TD-	positive supply voltage
Pin 5	n. c.	-
Pin 4	n. c.	-
Pin 3	TD+	positive supply voltage
Pin 2	RD-	negative supply voltage
Pin 1	RD+	negative supply voltage

### 3.3 TP ports (twisted pair)

---

**Note****Permitted cable lengths**

TP cords or TP-XP cords with a maximum length of 10 m can be connected to the TP port with the RJ-45 jack.

With the IE FC cables and IE FC RJ-45 plugs 180, an overall cable length of a maximum of 100 m is permitted between two devices depending on the cable type.

---

### Autonegotiation

With the autonegotiation mechanism, repeaters and end devices can automatically determine the transmission speed and the transmission mode of the partner port. This makes it possible to configure different devices automatically.

Two components connected to a link segment can exchange information about the data transfer and can adapt their settings to each other. The mode with the highest possible speed is set.

---

**Note**

Devices not supporting autonegotiation must be set permanently to 100 Mbps half duplex or 10 Mbps half duplex.

---

---

**Note**

The IE switches of the SCALANCE X-100 product line are plug-and-play devices that require no settings during commissioning.

---

### Auto polarity exchange

If the pair of receiving cables is connected incorrectly (RD+ and RD- interchanged), the polarity is adapted automatically.

### MDI / MDI-X autocrossover function

With the MPI/MDI-X autocrossover function, the send and receive contacts of an Ethernet port are assigned automatically. The assignment depends on the cable with which the communications partner is connected. This means that it does not matter whether the port is connected using a patch cable or crossover cable. This prevents malfunctions resulting from mismatching send and receive wires. This makes installation much easier for the user.

The IE Switches SCALANCE X-100 all support the MDI / MDI-X autocrossover function.

**NOTICE****Formation of loops**

Note that the direct connection of two ports or accidental connection over several switches causes an illegal loop that can cause network overload and failure.

## 3.4 FO port (fiber optic)

### Transmission speed

The transmission speed of the optical Fast Ethernet ports is 100 Mbps.

### Transmission technique

The transmission mode for 100Base-FX is specified in the IEEE 802.3 standard.

Since the full duplex mode and the transmission rate cannot be modified for optical transmission, autonegotiation cannot be selected.

### Transmission medium

Data transmission is over multimode fiber-optic cable (FO cable). The wavelength is 1310 nm.

Multimode fiber-optic cables are used with a core of 50 or 62.5  $\mu\text{m}$ ; the light source is an LED.

The outer diameter of the FO cable is 125  $\mu\text{m}$ .

### Transmission range

The maximum transmission range (segment length) is as follows:

- with 62.5/125  $\mu\text{m}$  fiber multimode SIMATIC NET cable: 4 km
- with 50.0/125  $\mu\text{m}$  fiber multimode SIMATIC NET cable: 5 km

### Connectors

The cables are connected over BFOC sockets.

3.5 LED display

### 3.5 LED display

#### Fault LED "F" (red LED)

The fault LED indicates the incorrect functioning of the device.

LED color	LED status	Meaning
Red	Lit	The IE switch detects an error. At the same time, the signaling contact opens. The following faults/errors are detected: 1. Link down event on a monitored port. 2. Loss of the power supply of one of the two redundant power supplies or the power supply drops below 9.6 V. 3. Both power supplies are below approximately 9.6 V (voltage too low).
-	Off	No error detected.

#### Power LEDs "L1" and "L2" (green LEDs)

The power LEDs show the status of the power supply at connectors L1 and L2.

L1/L2 LEDs		L1/L2 connector
LED color	LED status	
Green	Lit	Power supply L1 or L2 is connected.
-	Off	Power supply L1 and L2 are not connected or L1 and L2 <9.6 V.

**Note**

If the green LED is not lit, no other signal LED lights up either.

#### Port LEDs "P" (green/yellow LEDs)

The port LEDs indicate the status of the ports.

LED color	LED status	Meaning
Green	Lit	Link exists, no data reception at port
Yellow	Lit	Link exists, data reception at port
Yellow	Flashing	Setting or display of the fault mask



## 3.6 SET button

### Function

With the SET button, you can display and change the set fault mask.

### Setting the fault mask

#### Factory setting

In its delivery condition (factory default), the following settings are monitored via the message screen:

- Link up to all ports
- Redundant power supply (L1+/M1 und L2+/M2) connected

When you turn the device on and at least one of the settings is not fulfilled, the device registers a fault. Switch the device to the required operating mode and save these settings in the message screen.

#### Changing the setting

The changed settings remain after cycling power to the device.

Different settings are made depending on how long you hold down the SET button, as described in the following table:

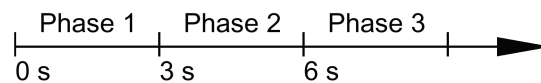

Time the button is pressed  
in seconds

Phase	Description	
1	LEDs flash at 5 Hz	The currently set fault mask is displayed. The LEDs of the monitored ports flash. If no fault mask is set, all port LEDs flash one after the other.
	If you release the button in phase 1, this has no effect.	
2	LEDs flash at 2.5 Hz	The current status is displayed. • The LEDs of the ports at which there is currently a link flash.
	If you release the button in phase 2, this has no effect.	
3	This new status is adopted and stored as the new fault mask in phase 3.	
	LEDs flashing	If you release the SET button while the LEDs are still flashing, storing is aborted.
	LEDs lit	If you release the SET button as soon as the LEDs light up, the current settings will be stored. The stored status is displayed. • The monitored ports are indicated by statically lit LEDs. • The monitored power supply is indicated by statically lit LEDs.

**Error/fault**

If the link is lost (link down) at a monitored port or a monitored power supply is lost, this is signaled as follows:

- The red fault LED lights up.
- The signaling contact is opened.

# Assembly

## 4.1 Safety notices for installation

### Safety notices

When installing the device, keep to the safety notices listed below.

 **WARNING**

**Ambient temperature above 55 °C**

If a device is operated in an ambient temperature of more than 55 °C, the temperature of the device housing may be higher than 70 °C. The device must therefore be installed so that it is only accessible to service personnel or users that are aware of the reason for restricted access and the required safety measures at an ambient temperature higher than 55 °C.

 **WARNING**

If a SCALANCE X108PoE is operated at ambient temperatures between 55 °C and 60 °C, there must be a minimum clearance of 40 mm to neighboring modules.

### Safety notices on use in hazardous areas

#### General safety notices relating to protection against explosion

 **WARNING**

**EXPLOSION HAZARD**

Replacing components may impair suitability for Class 1, Division 2 or Zone 2.

 **WARNING**

The device may only be operated in an environment with pollution degree 1 or 2 (see IEC 60664-1).

 **WARNING**

When used in hazardous environments corresponding to Class I, Division 2 or Class I, Zone 2, the device must be installed in a cabinet or a suitable enclosure.

**Safety notices for use according to ATEX and IECEx**

If you use the device under ATEX or IECEx conditions you must also keep to the following safety notices in addition to the general safety notices for protection against explosion:

 **WARNING**

To comply with EC Directive 2014/34/EU (ATEX 114) or the conditions of IECEx, this enclosure or cabinet must meet the requirements of at least IP54 in compliance with EN 60529.

 **WARNING**

If the cable or conduit entry point exceeds 70 °C or the branching point of conductors exceeds 80 °C, special precautions must be taken. If the equipment is operated in an air ambient in excess of 50 °C to 60 °C, only use cables with admitted maximum operating temperature of at least 80 °C.

**Further notes**

 **CAUTION**

**Use only approved components**

If you use components and accessories that are not approved for SIMATIC NET devices or their target systems, this may violate the requirements and regulations for safety and electromagnetic compatibility.

Only use components approved for the SIMATIC NET devices.

**NOTICE**

**Warming and premature aging of the IE switch due to direct sunlight**

Direct sunlight can heat up the device and can lead to premature aging of the IE switch and its cabling.

Provide suitable shade to protect the IE switch against direct sunlight.

**Note**

During installation and operation, keep to the installation guidelines and safety notices described in this document and in the system manuals "Industrial Ethernet / PROFINET Industrial Ethernet" and "Industrial Ethernet / PROFINET passive network components".

You will find information on the system manuals in the section "AUTOHOTSPOT", in "Further documentation".

---

## 4.2 Types of installation

The devices can be installed in the following ways:

- Installation on a 35 mm DIN rail
- Installation on a SIMATIC S7-300 standard rail
- Wall mounting

** WARNING**

If a device is operated in an ambient temperature between 50 °C and 75 °C, the temperature of the device housing may be higher than 70 °C. The device must therefore be installed so that it is only accessible to service personnel or users that are aware of the reason for restricted access and the required safety measures at an ambient temperature of 50 °C to 75 °C.

**Installation clearance**

Keep to the minimum clearances so that the convection ventilation of the device is not blocked.

- Below at least 10 cm
- Above at least 10 cm

## 4.3 Installation on a DIN rail

**Installation**

To install the device on a 35 mm DIN rail complying with DIN EN 50022, follow the steps below:

1. Place the second housing guide of the device on the top edge of the DIN rail.
2. Press the device down against the DIN rail until the spring catch locks in place.
3. Fit the connectors for the power supply. See also section "Power supply (Page 37)".

4. Fit the connectors for the signaling contacts. See also section "Signaling contacts (Page 38)".
5. Insert the terminal blocks into the sockets on the device.

**⚠ WARNING**

**Use of the SCALANCE X108PoE in shipbuilding**

When used in shipbuilding, mounting the SCALANCE X108PoE on 35 mm DIN rails is not permitted.

35 mm DIN rails do not ensure sufficient stability when used in shipbuilding.

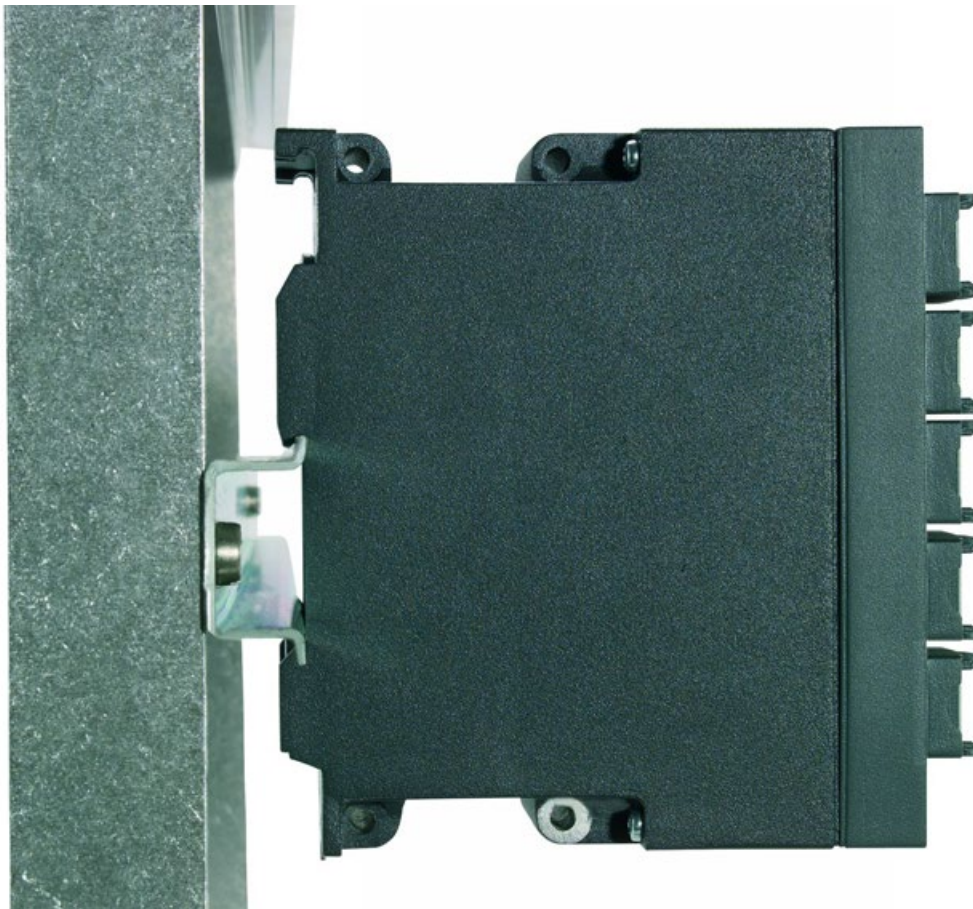

Figure 4-1 Installation on a 35 mm DIN rail

### Uninstalling

To remove the device from the DIN rail, follow the steps below:

1. Disconnect all connected cables.
2. Release the DIN rail catch on the bottom of the device using a screwdriver.
3. Pull the lower part of the device away from the DIN rail.

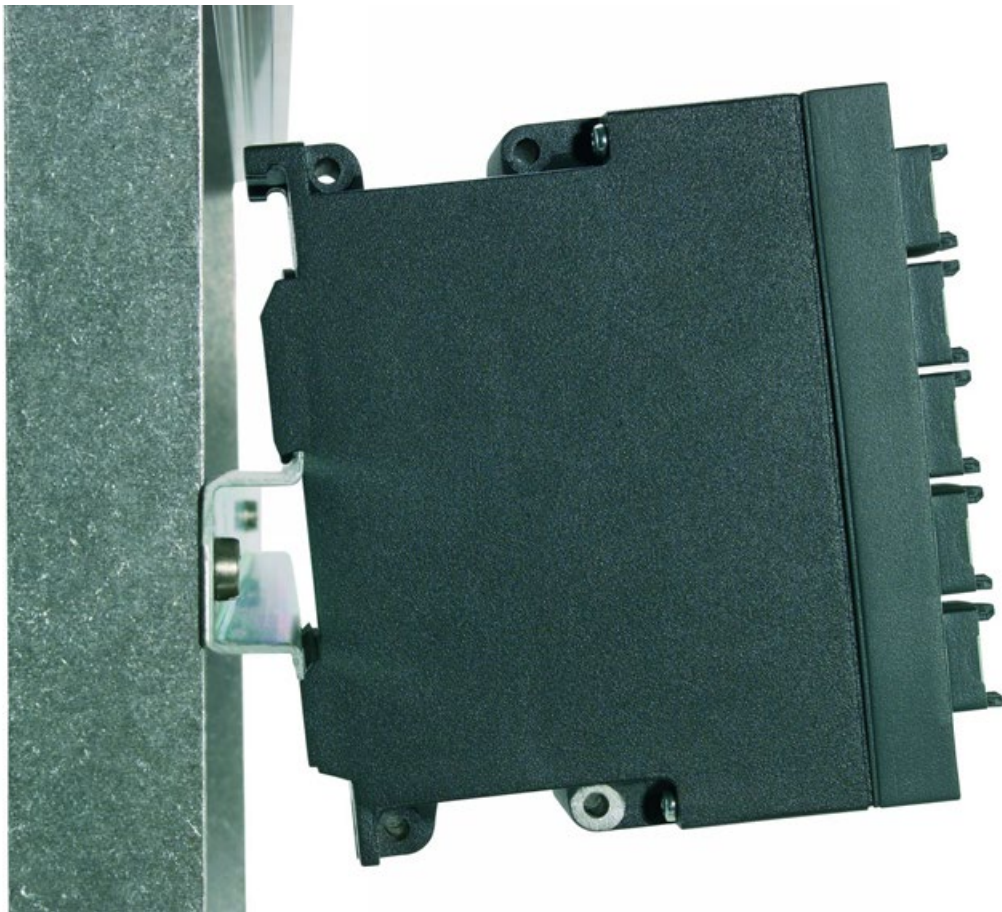

Figure 4-2 Removal from a 35 mm DIN rail

## 4.4 Installation on a standard rail

### Installation on a SIMATIC S7-300 standard rail

To install the device on an S7-300 standard rail, follow the steps below:

1. Place the first housing guide of the device on the top edge of the S7-300 standard rail.
2. Screw the device to the underside of the standard rail (tightening torque 2 Nm).
3. Fit the connectors for the power supply. See also section "Power supply (Page 37)".

4. Fit the connectors for the signaling contacts. See also section "Signaling contacts (Page 38)".
5. Insert the terminal blocks into the sockets on the device.

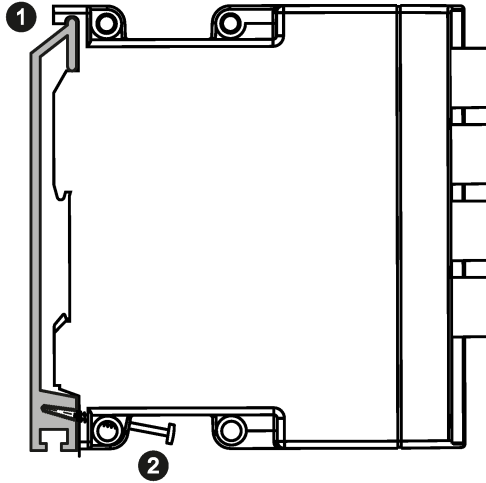

Figure 4-3 Installation on a SIMATIC S7-300 standard rail

## Uninstalling

To remove the device from the S7-300 standard rail, follow the steps below:

1. Disconnect all connected cables.
2. Release the screw holding the device on the bottom of the standard rail.
3. Lift the device off the standard rail.



## 4.5 Wall mounting

---

**Note**

Depending on the mounting surface, use suitable fittings.

---

**Note**

The wall mounting must be capable of supporting at least four times the weight of the device.

---

To mount the device on a wall, follow the steps below:

1. Prepare the drill holes for wall mounting. For the precise dimensions, refer to the section "Dimension drawings (Page 69)".
2. Screw the device to the wall using the keyhole hang-up mechanisms.
3. Fit the connectors for the power supply, see the section "Power supply (Page 37)".
4. Fit the connectors for the signaling contact, refer to the section ""Signaling contacts (Page 38)".



## Connecting up

### 5.1 Safety when connecting up

#### Safety notices

When connecting up the device, keep to the safety notices listed below.

 <b>WARNING</b>
<p>The equipment is designed for operation with Safety Extra-Low Voltage (SELV) by a Limited Power Source (LPS).</p> <p>This means that only SELV / LPS complying with IEC 60950-1 / EN 60950-1 / VDE 0805-1 must be connected to the power supply terminals. The power supply unit for the equipment power supply must comply with NEC Class 2, as described by the National Electrical Code (r) (ANSI / NFPA 70).</p> <p>If the equipment is connected to a redundant power supply (two separate power supplies), both must meet these requirements.</p>

<b>NOTICE</b>
<p><b>Failure of the data traffic due to contamination of optical plug-in connections</b></p> <p>Optical sockets and plugs are sensitive to contamination of the end face. Contamination can lead to the failure of the optical transmission network.</p> <p>Close unused optical sockets and plugs as well as pluggable transceivers and slots with the supplied protective caps.</p> <p>Remove the protective caps only immediately before you use the plug-in connection.</p>

#### Safety notices on use in hazardous areas

##### General safety notices relating to protection against explosion

 <b>WARNING</b>
<p><b>EXPLOSION HAZARD</b></p> <p>Do not connect or disconnect cables to or from the device when a flammable or combustible atmosphere is present.</p>

**Safety notices when using the device according to Hazardous Locations (HazLoc)**

If you use the device under HazLoc conditions you must also keep to the following safety notices in addition to the general safety notices for protection against explosion:

 <b>WARNING</b>
<b>EXPLOSION HAZARD</b>
Do not connect or disconnect while the circuit is live or unless the area is known to be free of ignitable concentrations.

**Safety notices for use according to ATEX and IECEx**

If you use the device under ATEX or IECEx conditions you must also keep to the following safety notices in addition to the general safety notices for protection against explosion:

 <b>WARNING</b>
Take measures to prevent transient voltage surges of more than 40% of the rated voltage. This is the case if you only operate devices with SELV (safety extra-low voltage).

## 5.2 Power supply

The power supply is connected using a 4-pin plug-in terminal block. The power supply can be connected redundantly. Both inputs are isolated. There is no distribution of load. When a redundant power supply is used, the power supply unit with the higher output voltage supplies the device alone. The power supply is connected over a high resistance with the enclosure to allow an ungrounded set up. The two power supplies are non-floating.

The following figure shows the position of the power supply of the SCALANCE X-100 IE switches and the assignment of the terminal block.

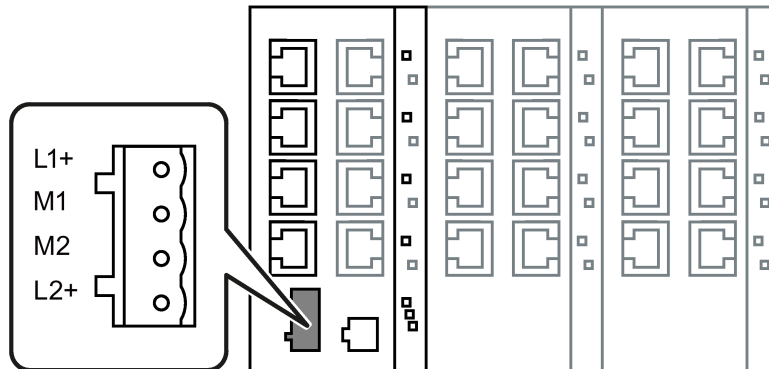

Pin number	Assignment
Pin 1	L1+ (24 VDC)
Pin 2	M1 (ground)
Pin 3	M2 (ground)
Pin 4	L2+ (24 VDC)

### **!** WARNING

#### **Incorrect power supply**

The power supply unit to supply the device must comply with NEC Class 2 (voltage range 18 - 32 V, current requirement 350 mA).

Do not operate the device with an AC voltage.

Never operate the device with DC voltages higher than 32 VDC.

### 5.3 Signaling contact

The signaling contact is connected to a 2-pin plug-in terminal block. The signaling contact (relay contact) is a floating switch with which error/fault states can be signaled by breaking the contact.

**NOTICE**

**Damage due to voltage being too high**

The signaling contact can be subjected to a maximum load of 100 mA (safety extra-low voltage SELV, 24 VDC).

Higher voltages or currents can damage the device!

The following figure shows the position of the signaling contacts of the SCALANCE X-100 IE switches and the assignment of the terminal block.

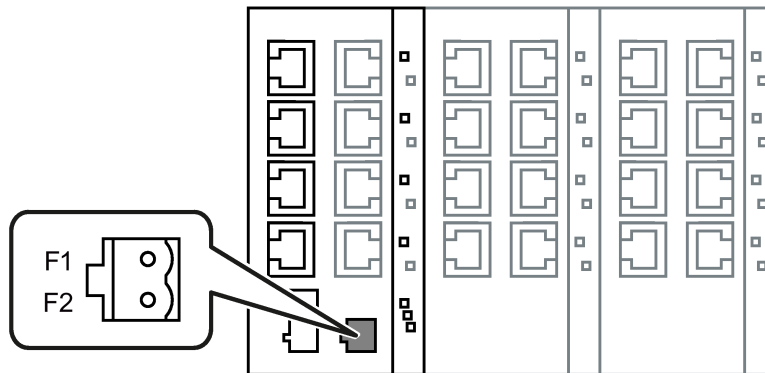

Pin number	Assignment
Pin 1	F1
Pin 2	F2

Pin 1	F1
Pin 2	F2

The following errors/faults can be signaled by the signaling contact:

- The failure of a link at a monitored port.
- The failure of one of the two monitored power supplies.

The connection or disconnection of a communication node on an unmonitored port does not lead to an error message.

The signaling contact remains activated until the error/fault is eliminated or until the current status is applied as the new desired status using the button.

When the device is turned off, the signaling contact is always activated (open).

## 5.4 Grounding

### Installation on a DIN rail

The device is grounded over the DIN rail.

### S7 standard rail

The device is grounded over its rear panel and the neck of the screw.

### Wall mounting

The device is grounded by the securing screw in the unpainted hole.

Note that the device must be grounded over a securing screw with as low a low resistance as possible.

If the device is mounted on a non-conductive base, a grounding cable must be fitted. The grounding cable is not supplied with the device. Connect the paint-free surface of the device to the nearest grounding point using the grounding cable.

## 5.5 IE FC RJ-45 Plug 180

The rugged node connectors are designed for industry with PROFINET-compliant connectors and provide additional strain and bending relief with a locking mechanism on the casing.

### Fitting the IE FC RJ45 Plug 180 to the IE FC Standard Cable

You will find the notes on installation in the instructions that ship with the IE FC RJ45 Plug 180.

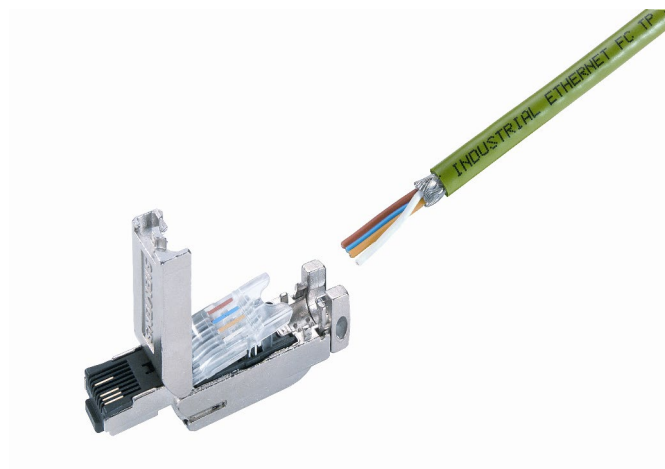

Figure 5-1 IE FC 45 Plug 180

### Plugging in the IE FC RJ45 Plug 180

Plug the IE FC RJ45 Plug 180 into the twisted-pair port of the device until it locks in place.



Figure 5-2 Plugging in the IE FC RJ45 Plug 180

With its tight fit and locking mechanism with the PROFINET-compliant male connector IE FC RJ45 Plug 180, the securing collar on the TP port of the device ensures a rugged node attachment that provides strain and bending relief for the RJ-45 jack.

### Pulling the IE FC RJ45 Plug 180

Press on the locking lever of the IE FC RJ45 Plug 180 gently to remove the plug.

If there is not enough space to release the lock with your hand, you can also use a 2.5 mm screwdriver. You can then remove the IE FC RJ45 Plug 180 from the RJ-45 jack.



## Maintenance and troubleshooting

### 6.1 Possible sources of problems and how to deal with them

#### Fuses

Some of the Industrial Ethernet switches of the SCALANCE X-100 product line have a resettable fuse / PTC. If the fuse triggers (all LEDs are off despite correctly applied power supply), the device should be disconnected from the power supply for approximately 30 minutes before turning it on again.

#### Link display on the optical ports

The Industrial Ethernet switches SCALANCE X104-2, SCALANCE X106-1 and SCALANCE X112-2 support "far-end fault" on the optical ports but do not use this for the corresponding link display. This means that if there is only a cable connected in the receive direction on the optical port, a far-end fault is detected and no data is forwarded. The Link LED is already lit.

#### LED display when voltage drops

If both of the power supplies drop below approximately 14 V, this reduced voltage is indicated by the red fault LED. The L LEDs go off.

#### Device defective

If a fault develops, please send the device to your SIEMENS service center for repair. Repairs on-site are not possible.



# Technical specifications

## 7.1 SCALANCE X104-2

Table 7- 1 Technical specifications of the SCALANCE X104-2

<b>Technical specifications</b>		
<b>Order number</b>		
SCALANCE X104-2	6GK5104-2BB00-2AA3	
<b>Connection to Industrial Ethernet</b>		
Number	4	
Design	RJ-45 jacks with MDI-X pinning	
Properties	Half / full duplex	
Transmission speed	10/100 Mbps	
<b>Optical connectors</b>		
Number	2	
Design	BFOC sockets	
Properties	Full duplex to 100 Base-FX	
Transmission speed	100 Mbps	
<b>Permitted cable lengths (Industrial Ethernet)</b>	<b>Alternative combinations per length range</b>	
0 to 55 m	<ul style="list-style-type: none"> <li>Max. 55 m IE TP Torsion Cable with IE FC RJ45 Plug 180</li> <li>Max. 45 m IE TP Torsion Cable with IE FC RJ45 + 10 m TP Cord via IE FC RJ45 Outlet</li> </ul>	
0 to 85 m	<ul style="list-style-type: none"> <li>Max. 85 m IE FC TP Marine/Trailing Cable with IE FC RJ45 Plug 180</li> <li>Max. 75 m IE FC TP Marine/Trailing Cable + 10 m TP Cord via IE FC RJ45 Outlet</li> </ul>	
0 to 100 m	<ul style="list-style-type: none"> <li>Max. 100 m IE FC TP Standard Cable with IE FC RJ45 Plug 180</li> <li>Max. 90 m IE FC TP Standard Cable + 10 m TP Cord via IE FC RJ45 Outlet</li> </ul>	
<b>Optical parameters</b>		
Cable type	Multimode glass FO cable, cable cross sections 62.5/125 µm and 50/125 µm	
Permitted cable length (glass FO cable)	Cable cross-section	Permitted cable length
	<ul style="list-style-type: none"> <li>62.5/125 µm</li> <li>50/125 µm</li> </ul>	<ul style="list-style-type: none"> <li>0 to 4000 m</li> <li>0 to 5000 m</li> </ul>
Attenuation	≤ 1 dB/km at 1300 nm 1200 MHz x km at 1300 nm 6 dB max. permitted FO cable attenuation with 3 dB link power margin	

## Technical specifications

### 7.1 SCALANCE X104-2

#### Technical specifications

##### Electrical data

Power supply	Voltage range	18 to 32 VDC Safe Extra Low Voltage (SELV)
	Rated voltage	24 VDC
	Design	4-terminal plug-in block
Signaling contact	Current	max. 100 mA
	Rated voltage	24 VDC
	Design	2-pin plug-in terminal block
Current consumption	Typical	160 mA
Power loss at 24 VDC	Typical	3.8 W
Overvoltage protection at input		PTC resettable fuse (0.6 A / 60 V)

##### Permitted ambient conditions

Ambient temperature	During operation	-10 °C to +60 °C
	During storage	-40 °C to +80 °C
	During transportation	-40 °C to +80 °C
Relative humidity	During operation	≤ 95 % no condensation
Operating altitude	During operation	≤ 2,000 m above sea level at max. 56 °C ambient temperature
		≤ 3,000 m above sea level at max. 50 °C ambient temperature

##### Design, dimensions and weight

Immunity to interference	EN 61000-6-2	
Emission	EN 61000-6-4	
Degree of protection	IP 30	
MTBF (EN/IEC 61709, 40 °C)	134.87 years	
Housing material	Basic housing	Die cast aluminum, powder coated
	Front cover	Polyphenylene ether + polystyrene (PPE+PS plastic)
Weight	780 g	
Dimensions (W x H x D)	60 x 125 x 124 mm	
Installation options	<ul style="list-style-type: none"><li>• Installation on a DIN rail</li><li>• Installation on an S7-300 standard rail</li><li>• Wall mounting</li></ul>	

##### Switching properties

Aging time	30 seconds
Max. number of learnable MAC addresses	2048
Response to LLDP frames	Blocking
Response to spanning tree BPDU frames	Forwarding
CoS acc. to IEEE 802.1Q	Yes
QoS priority queues	4

**Note**

The number of SCALANCE X Industrial Ethernet switches connected in a line influences the frame delay time.

When a frame passes through devices of the SCALANCE X-100 product line, it is delayed by the store and forward function of the switch

- with a 64 byte frame length by approx. 10 microseconds (at 100 Mbps)
- with a 1500 byte frame length by approx. 130 microseconds (at 100 Mbps)

This means that the more devices of the SCALANCE X-100 product line, the frame passes through, the longer the frame delay.

**Note**

**Temperature code for c-UL-us for hazardous locations, FM and ATEX Zone 2**

You will find the temperature code "T.." or the maximum ambient temperature "Ta: .." on the type plate.

## 7.2 SCALANCE X106-1

Table 7- 2 Technical specifications of the SCALANCE X106-1

<b>Technical specifications</b>	
<b>Order number</b>	
SCALANCE X106-1	6GK5106-1BB00-2AA3
<b>Connection to Industrial Ethernet</b>	
Number	6
Design	RJ-45 jacks with MDI-X pinning
Properties	Half / full duplex
Transmission speed	10/100 Mbps
<b>Optical connectors</b>	
Number	1
Design	BFOC socket
Properties	Full duplex to 100 Base-FX
Transmission speed	100 Mbps
<b>Permitted cable lengths (Industrial Ethernet)</b>	<b>Alternative combinations per length range</b>
0 to 55 m	<ul style="list-style-type: none"> <li>• Max. 55 m IE TP Torsion Cable with IE FC RJ45 Plug 180</li> <li>• Max. 45 m IE TP Torsion Cable with IE FC RJ45 + 10 m TP Cord via IE FC RJ45 Outlet</li> </ul>
0 to 85 m	<ul style="list-style-type: none"> <li>• Max. 85 m IE FC TP Marine/Trailing Cable with IE FC RJ45 Plug 180</li> <li>• Max. 75 m IE FC TP Marine/Trailing Cable + 10 m TP Cord via IE FC RJ45 Outlet</li> </ul>

**Technical specifications**

- |            |                                                                                                                                                                                                   |
|------------|---------------------------------------------------------------------------------------------------------------------------------------------------------------------------------------------------|
| 0 to 100 m | <ul style="list-style-type: none"> <li>• Max. 100 m IE FC TP Standard Cable with IE FC RJ45 Plug 180</li> <li>• Max. 90 m IE FC TP Standard Cable + 10 m TP Cord via IE FC RJ45 Outlet</li> </ul> |
|------------|---------------------------------------------------------------------------------------------------------------------------------------------------------------------------------------------------|

**Optical parameters**

Cable type	Multimode glass FO cable, cable cross sections 62.5/125 µm and 50/125 µm	
Permitted cable length (glass FO cable)	Cable cross-section	Permitted cable length
	<ul style="list-style-type: none"> <li>• 62.5/125 µm</li> <li>• 50/125 µm</li> </ul>	<ul style="list-style-type: none"> <li>• 0 to 4000 m</li> <li>• 0 to 5000 m</li> </ul>
Attenuation	≤ 1 dB/km at 1300 nm 1200 MHz x km at 1300 nm 6 dB max. permitted FO cable attenuation with 3 dB link power margin	

**Electrical data**

Power supply	Voltage range	18 to 32 VDC Safe Extra Low Voltage (SELV)
	Rated voltage	24 VDC
	Design	4-terminal plug-in block
Signaling contact	Current	max. 100 mA
	Rated voltage	24 VDC
	Design	2-pin plug-in terminal block
Current consumption	Typical	150 mA
Power loss at 24 VDC	Typical	3.6 W
Overvoltage protection at input	PTC resettable fuse (0.6 A / 60 V)	

**Permitted ambient conditions**

Ambient temperature	During operation	-10 °C to +60 °C
	During storage	-40 °C to +80 °C
	During transportation	-40 °C to +80 °C
Relative humidity	During operation	≤ 95 % no condensation
Operating altitude	During operation	≤ 2,000 m above sea level at max. 56 °C ambient temperature
		≤ 3,000 m above sea level at max. 50 °C ambient temperature

**Design, dimensions and weight**

Immunity to interference	EN 61000-6-2	
Emission	EN 61000-6-4	
Degree of protection	IP 30	
MTBF (EN/IEC 61709, 40 °C)	136.65 years	
Housing material	Basic housing	Die cast aluminum, powder coated
	Front cover	Polyphenylene ether + polystyrene (PPE+PS plastic)
Weight	780 g	
Dimensions (W x H x D)	60 x 125 x 124 mm	

---

**Technical specifications**

---

Installation options	<ul style="list-style-type: none"><li>• Installation on a DIN rail</li><li>• Installation on an S7-300 standard rail</li><li>• Wall mounting</li></ul>
----------------------	--------------------------------------------------------------------------------------------------------------------------------------------------------

---

**Switching properties**

---

Aging time	30 seconds
------------	------------

---

Max. number of learnable MAC addresses	2048
----------------------------------------	------

---

Response to LLDP frames	Blocking
-------------------------	----------

---

Response to spanning tree BPDU frames	Forwarding
---------------------------------------	------------

---

CoS acc. to IEEE 802.1Q	Yes
-------------------------	-----

---

QoS priority queues	4
---------------------	---

---

---

**Note**

The number of SCALANCE X Industrial Ethernet switches connected in a line influences the frame delay time.

When a frame passes through devices of the SCALANCE X-100 product line, it is delayed by the store and forward function of the switch

- with a 64 byte frame length by approx. 10 microseconds (at 100 Mbps)
- with a 1500 byte frame length by approx. 130 microseconds (at 100 Mbps)

This means that the more devices of the SCALANCE X-100 product line, the frame passes through, the longer the frame delay.

---

**Note****Temperature code for c-UL-us for hazardous locations, FM and ATEX Zone 2**

You will find the temperature code "T.." or the maximum ambient temperature "Ta: .." on the type plate.

---

## 7.3 SCALANCE X108

Table 7- 3 Technical specifications of the SCALANCE X108

<b>Technical specifications</b>		
<b>Order number</b>		
SCALANCE X108	6GK5108-0BA00-2AA3	
<b>Connection to Industrial Ethernet</b>		
Number	8	
Design	RJ-45 jacks with MDI-X pinning	
Properties	Half / full duplex	
Transmission speed	10/100 Mbps	
<b>Permitted cable lengths (Industrial Ethernet)</b>	<b>Alternative combinations per length range</b>	
0 to 55 m	<ul style="list-style-type: none"> <li>Max. 55 m IE TP Torsion Cable with IE FC RJ45 Plug 180</li> <li>Max. 45 m IE TP Torsion Cable with IE FC RJ45 + 10 m TP Cord via IE FC RJ45 Outlet</li> </ul>	
0 to 85 m	<ul style="list-style-type: none"> <li>Max. 85 m IE FC TP Marine/Trailing Cable with IE FC RJ45 Plug 180</li> <li>Max. 75 m IE FC TP Marine/Trailing Cable + 10 m TP Cord via IE FC RJ45 Outlet</li> </ul>	
0 to 100 m	<ul style="list-style-type: none"> <li>Max. 100 m IE FC TP Standard Cable with IE FC RJ45 Plug 180</li> <li>Max. 90 m IE FC TP Standard Cable + 10 m TP Cord via IE FC RJ45 Outlet</li> </ul>	
<b>Electrical data</b>		
Power supply	Voltage range	18 to 32 VDC Safe Extra Low Voltage (SELV)
	Rated voltage	24 VDC
	Design	4-terminal plug-in block
Signaling contact	Current	max. 100 mA
	Rated voltage	24 VDC
	Design	2-pin plug-in terminal block
Current consumption	Typical	140 mA
Power loss at 24 VDC	Typical	3.36 W
Overvoltage protection at input	PTC resettable fuse (0.6 A / 60 V)	
<b>Permitted ambient conditions</b>		
Ambient temperature	During operation	-20 °C to +70 °C
	During storage	-40 °C to +80 °C
	During transportation	-40 °C to +80 °C
Relative humidity	During operation	≤ 95 % no condensation
Operating altitude	During operation	≤ 2,000 m above sea level at max. 56 °C ambient temperature
		≤ 3,000 m above sea level at max. 50 °C ambient temperature



<b>Technical specifications</b>		
<b>Design, dimensions and weight</b>		
Immunity to interference	EN 61000-6-2	
Emission	EN 61000-6-4	
Degree of protection	IP 30	
MTBF (EN/IEC 61709, 40 °C)	139.83 years	
Housing material	Basic housing	Die cast aluminum, powder coated
	Front cover	Polyphenylene ether + polystyrene (PPE+PS plastic)
Weight	780 g	
Dimensions (W x H x D)	60 x 125 x 124 mm	
Installation options	<ul style="list-style-type: none"> <li>• Installation on a DIN rail</li> <li>• Installation on an S7-300 standard rail</li> <li>• Wall mounting</li> </ul>	
<b>Switching properties</b>		
Aging time	30 seconds	
Max. number of learnable MAC addresses	2048	
Response to LLDP frames	Blocking	
Response to spanning tree BPDU frames	Forwarding	
CoS acc. to IEEE 802.1Q	Yes	
QoS priority queues	4	

**Note**

The number of SCALANCE X Industrial Ethernet switches connected in a line influences the frame delay time.

When a frame passes through devices of the SCALANCE X-100 product line, it is delayed by the store and forward function of the switch

- with a 64 byte frame length by approx. 10 microseconds (at 100 Mbps)
- with a 1500 byte frame length by approx. 130 microseconds (at 100 Mbps)

This means that the more devices of the SCALANCE X-100 product line, the frame passes through, the longer the frame delay.

**Note**

**Temperature code for c-UL-us for hazardous locations, FM and ATEX Zone 2**

You will find the temperature code "T.." or the maximum ambient temperature "Ta: .." on the type plate.

## 7.4 SCALANCE X108PoE

Table 7- 4 Technical specifications of the SCALANCE X108PoE

<b>Technical specifications</b>		
<b>Order number</b>		
SCALANCE X108PoE	6GK5108-0PA00-2AA3	
<b>Connection to Industrial Ethernet</b>		
Number	8	
Design	RJ-45 jacks with MDI-X pinning	
Properties	Half / full duplex	
Transmission speed	10/100 Mbps	
<b>Permitted cable lengths (Industrial Ethernet)</b>	<b>Alternative combinations per length range</b>	
0 to 55 m	<ul style="list-style-type: none"> <li>Max. 55 m IE TP Torsion Cable with IE FC RJ45 Plug 180</li> <li>Max. 45 m IE TP Torsion Cable with IE FC RJ45 + 10 m TP Cord via IE FC RJ45 Outlet</li> </ul>	
0 to 85 m	<ul style="list-style-type: none"> <li>Max. 85 m IE FC TP Marine/Trailing Cable with IE FC RJ45 Plug 180</li> <li>Max. 75 m IE FC TP Marine/Trailing Cable + 10 m TP Cord via IE FC RJ45 Outlet</li> </ul>	
0 to 100 m	<ul style="list-style-type: none"> <li>Max. 100 m IE FC TP Standard Cable with IE FC RJ45 Plug 180</li> <li>Max. 90 m IE FC TP Standard Cable + 10 m TP Cord via IE FC RJ45 Outlet</li> </ul>	
<b>Electrical data</b>		
Power supply	Voltage range	18 to 32 VDC Safe Extra Low Voltage (SELV)
	Rated voltage	24 VDC
	Design	4-terminal plug-in block
Signaling contact	Current	max. 100 mA
	Rated voltage	24 VDC
	Design	2-pin plug-in terminal block
Current consumption	Typical	1700 mA
Power loss at 24 VDC	Typical	10.0 W
Overvoltage protection at input	Fuse slow (4 A / 125 V)	
<b>Permitted ambient conditions</b>		
Ambient temperature	During operation	-20 °C to +60 °C
	During storage	-40 °C to +80 °C
	During transportation	-40 °C to +80 °C
Relative humidity	During operation	≤ 95 % no condensation
Operating altitude	During operation	≤ 2,000 m above sea level at max. 56 °C ambient temperature
		≤ 3,000 m above sea level at max. 50 °C ambient temperature

<b>Technical specifications</b>		
<b>Design, dimensions and weight</b>		
Immunity to interference	EN 61000-6-2	
Emission	EN 61000-6-4	
Degree of protection	IP 30	
MTBF (EN/IEC 61709, 40 °C)	61.64 years	
Housing material	Basic housing	Die cast aluminum, powder coated
	Front cover	Polyphenylene ether + polystyrene (PPE+PS plastic)
Weight	550 g	
Dimensions (W x H x D)	40 x 125 x 124 mm	
Installation options	<ul style="list-style-type: none"> <li>• Installation on a DIN rail</li> <li>• Installation on an S7-300 standard rail</li> <li>• Wall mounting</li> </ul>	
<b>Switching properties</b>		
Aging time	30 seconds	
Max. number of learnable MAC addresses	2048	
Response to LLDP frames	Blocking	
Response to spanning tree BPDU frames	Forwarding	
CoS acc. to IEEE 802.1Q	Yes	
QoS priority queues	4	
<b>PoE properties</b>		
PoE standard	802.3af	
Performance	maximum	15.4 W

**Note**

As of an ambient temperature of 55 °C, there must be a clearance of 40 mm to neighboring devices on both sides.

**Note**

The number of SCALANCE X Industrial Ethernet switches connected in a line influences the frame delay time.

When a frame passes through devices of the SCALANCE X-100 product line, it is delayed by the store and forward function of the switch

- with a 64 byte frame length by approx. 10 microseconds (at 100 Mbps)
- with a 1500 byte frame length by approx. 130 microseconds (at 100 Mbps)

This means that the more devices of the SCALANCE X-100 product line, the frame passes through, the longer the frame delay.

**Note**

**Temperature code for c-UL-us for hazardous locations, FM and ATEX Zone 2**

You will find the temperature code "T.." or the maximum ambient temperature "Ta: .." on the type plate.

## 7.5 SCALANCE X112-2

Table 7- 5 Technical specifications of the SCALANCE X112-1

Technical specifications		
<b>Order number</b>		
SCALANCE X112-2	6GK5112-2BB00-2AA3	
<b>Connection to Industrial Ethernet</b>		
Number	12	
Design	RJ-45 jacks with MDI-X pinning	
Properties	Half / full duplex	
Transmission speed	10/100 Mbps	
<b>Optical connectors</b>		
Number	2	
Design	BFOC sockets	
Properties	Full duplex to 100 Base-FX	
Transmission speed	100 Mbps	
<b>Permitted cable lengths (Industrial Ethernet)</b>	<b>Alternative combinations per length range</b>	
0 to 55 m	<ul style="list-style-type: none"> <li>Max. 55 m IE TP Torsion Cable with IE FC RJ45 Plug 180</li> <li>Max. 45 m IE TP Torsion Cable with IE FC RJ45 + 10 m TP Cord via IE FC RJ45 Outlet</li> </ul>	
0 to 85 m	<ul style="list-style-type: none"> <li>Max. 85 m IE FC TP Marine/Trailing Cable with IE FC RJ45 Plug 180</li> <li>Max. 75 m IE FC TP Marine/Trailing Cable + 10 m TP Cord via IE FC RJ45 Outlet</li> </ul>	
0 to 100 m	<ul style="list-style-type: none"> <li>Max. 100 m IE FC TP Standard Cable with IE FC RJ45 Plug 180</li> <li>Max. 90 m IE FC TP Standard Cable + 10 m TP Cord via IE FC RJ45 Outlet</li> </ul>	
<b>Optical parameters</b>		
Cable type	Multimode glass FO cable, cable cross sections 62.5/125 µm and 50/125 µm	
Permitted cable length (glass FO cable)	Cable cross-section	Permitted cable length
	<ul style="list-style-type: none"> <li>62.5/125 µm</li> </ul>	<ul style="list-style-type: none"> <li>0 to 4000 m</li> </ul>
	<ul style="list-style-type: none"> <li>50/125 µm</li> </ul>	<ul style="list-style-type: none"> <li>0 to 5000 m</li> </ul>

<b>Technical specifications</b>		
Attenuation	$\leq 1$ dB/km at 1300 nm 1200 MHz x km at 1300 nm 6 dB max. permitted FO cable attenuation with 3 dB link power margin	
<b>Electrical data</b>		
Power supply	Voltage range	18 to 32 VDC Safe Extra Low Voltage (SELV)
	Rated voltage	24 VDC
	Design	4-terminal plug-in block
Signaling contact	Current	max. 100 mA
	Rated voltage	24 VDC
	Design	2-pin plug-in terminal block
Current consumption	Typical	215 mA
Power loss at 24 VDC	Typical	5.16 W
<b>Permitted ambient conditions</b>		
Ambient temperature	During operation	-10 °C to +70 °C
	During storage	-40 °C to +80 °C
	During transportation	-40 °C to +80 °C
Relative humidity	During operation	$\leq 95$ % no condensation
Operating altitude	During operation	$\leq 2,000$ m above sea level at max. 56 °C ambient temperature
		$\leq 3,000$ m above sea level at max. 50 °C ambient temperature
<b>Design, dimensions and weight</b>		
Immunity to interference	EN 61000-6-2	
Emission	EN 61000-6-3	
Degree of protection	IP 30	
MTBF (EN/IEC 61709, 40 °C)	61.3 years	
Housing material	Basic housing	Die cast aluminum, powder coated
	Front cover	Polyphenylene ether + polystyrene (PPE+PS plastic)
Weight	1100 g	
Dimensions (W x H x D)	120 x 125 x 124 mm	
Installation options	<ul style="list-style-type: none"> <li>• Installation on a DIN rail</li> <li>• Installation on an S7-300 standard rail</li> <li>• Wall mounting</li> </ul>	
<b>Switching properties</b>		
Aging time	30 seconds	
Max. number of learnable MAC addresses	2048	
Response to LLDP frames	Blocking	
Response to spanning tree BPDU frames	Forwarding	

7.6 SCALANCE X116

Technical specifications	
CoS acc. to IEEE 802.1Q	Yes
QoS priority queues	4

**Note**

The number of SCALANCE X Industrial Ethernet switches connected in a line influences the frame delay time.

When a frame passes through devices of the SCALANCE X-100 product line, it is delayed by the store and forward function of the switch

- with a 64 byte frame length by approx. 10 microseconds (at 100 Mbps)
- with a 1500 byte frame length by approx. 130 microseconds (at 100 Mbps)

This means that the more devices of the SCALANCE X-100 product line, the frame passes through, the longer the frame delay.

**Note**

**Temperature code for c-UL-us for hazardous locations, FM and ATEX Zone 2**

You will find the temperature code "T.." or the maximum ambient temperature "Ta: .." on the type plate.

## 7.6 SCALANCE X116

Table 7- 6 Technical specifications of the SCALANCE X116

Technical specifications	
<b>Order number</b>	
SCALANCE X116	6GK5116-0BA00-2AA3
<b>Connection to Industrial Ethernet</b>	
Number	16
Design	RJ-45 jacks with MDI-X pinning
Properties	Half / full duplex
Transmission speed	10/100 Mbps
<b>Permitted cable lengths (Industrial Ethernet)</b>	<b>Alternative combinations per length range</b>
0 to 55 m	<ul style="list-style-type: none"> <li>• Max. 55 m IE TP Torsion Cable with IE FC RJ45 Plug 180</li> <li>• Max. 45 m IE TP Torsion Cable with IE FC RJ45 + 10 m TP Cord via IE FC RJ45 Outlet</li> </ul>
0 to 85 m	<ul style="list-style-type: none"> <li>• Max. 85 m IE FC TP Marine/Trailing Cable with IE FC RJ45 Plug 180</li> <li>• Max. 75 m IE FC TP Marine/Trailing Cable + 10 m TP Cord via IE FC RJ45 Outlet</li> </ul>

<b>Technical specifications</b>		
0 to 100 m		<ul style="list-style-type: none"> <li>• Max. 100 m IE FC TP Standard Cable with IE FC RJ45 Plug 180</li> <li>• Max. 90 m IE FC TP Standard Cable + 10 m TP Cord via IE FC RJ45 Outlet</li> </ul>
<b>Electrical data</b>		
Power supply	Voltage range	18 to 32 VDC Safe Extra Low Voltage (SELV)
	Rated voltage	24 VDC
	Design	4-terminal plug-in block
Signaling contact	Current	max. 100 mA
	Rated voltage	24 VDC
	Design	2-pin plug-in terminal block
Current consumption	Typical	185 mA
Power loss at 24 VDC	Typical	4.40 W
<b>Permitted ambient conditions</b>		
Ambient temperature	During operation	-20 °C to +70 °C
	During storage	-40 °C to +80 °C
	During transportation	-40 °C to +80 °C
Relative humidity	During operation	≤ 95 % no condensation
Operating altitude	During operation	≤ 2,000 m above sea level at max. 56 °C ambient temperature
		≤ 3,000 m above sea level at max. 50 °C ambient temperature
<b>Design, dimensions and weight</b>		
Immunity to interference	EN 61000-6-2	
Emission	EN 61000-6-3	
Degree of protection	IP 30	
MTBF (EN/IEC 61709, 40 °C)	61.3 years	
Housing material	Basic housing	Die cast aluminum, powder coated
	Front cover	Polyphenylene ether + polystyrene (PPE+PS plastic)
Weight	1100 g	
Dimensions (W x H x D)	120 x 125 x 124 mm	
Installation options	<ul style="list-style-type: none"> <li>• Installation on a DIN rail</li> <li>• Installation on an S7-300 standard rail</li> <li>• Wall mounting</li> </ul>	
<b>Switching properties</b>		
Aging time	30 seconds	
Max. number of learnable MAC addresses	2048	
Response to LLDP frames	Blocking	
Response to spanning tree BPDU frames	Forwarding	

7.7 SCALANCE X124

Technical specifications	
CoS acc. to IEEE 802.1Q	Yes
QoS priority queues	4

**Note**

The number of SCALANCE X Industrial Ethernet switches connected in a line influences the frame delay time.

When a frame passes through devices of the SCALANCE X-100 product line, it is delayed by the store and forward function of the switch

- with a 64 byte frame length by approx. 10 microseconds (at 100 Mbps)
- with a 1500 byte frame length by approx. 130 microseconds (at 100 Mbps)

This means that the more devices of the SCALANCE X-100 product line, the frame passes through, the longer the frame delay.

**Note**

**Temperature code for c-UL-us for hazardous locations, FM and ATEX Zone 2**

You will find the temperature code "T.." or the maximum ambient temperature "Ta: .." on the type plate.

## 7.7 SCALANCE X124

Table 7- 7 Technical specifications of the SCALANCE X124

Technical specifications	
<b>Order number</b>	
SCALANCE X124	6GK5124-0BA00-2AA3
<b>Connection to Industrial Ethernet</b>	
Number	24
Design	RJ-45 jacks with MDI-X pinning
Properties	Half / full duplex
Transmission speed	10/100 Mbps
<b>Permitted cable lengths (Industrial Ethernet)</b>	<b>Alternative combinations per length range</b>
0 to 55 m	<ul style="list-style-type: none"> <li>• Max. 55 m IE TP Torsion Cable with IE FC RJ45 Plug 180</li> <li>• Max. 45 m IE TP Torsion Cable with IE FC RJ45 + 10 m TP Cord via IE FC RJ45 Outlet</li> </ul>
0 to 85 m	<ul style="list-style-type: none"> <li>• Max. 85 m IE FC TP Marine/Trailing Cable with IE FC RJ45 Plug 180</li> <li>• Max. 75 m IE FC TP Marine/Trailing Cable + 10 m TP Cord via IE FC RJ45 Outlet</li> </ul>



**Technical specifications**

- |            |                                                                                                                                                                                                   |
|------------|---------------------------------------------------------------------------------------------------------------------------------------------------------------------------------------------------|
| 0 to 100 m | <ul style="list-style-type: none"> <li>• Max. 100 m IE FC TP Standard Cable with IE FC RJ45 Plug 180</li> <li>• Max. 90 m IE FC TP Standard Cable + 10 m TP Cord via IE FC RJ45 Outlet</li> </ul> |
|------------|---------------------------------------------------------------------------------------------------------------------------------------------------------------------------------------------------|

**Electrical data**

Power supply	Voltage range	18 to 32 VDC Safe Extra Low Voltage (SELV)
	Rated voltage	24 VDC
	Design	4-terminal plug-in block
Signaling contact	Current	max. 100 mA
	Rated voltage	24 VDC
	Design	2-pin plug-in terminal block
Current consumption	Typical	200 mA
Power loss at 24 VDC	Typical	4.80 W

**Permitted ambient conditions**

Ambient temperature	During operation	-20 °C to +70 °C
	During storage	-40 °C to +80 °C
	During transportation	-40 °C to +80 °C
Relative humidity	During operation	≤ 95 % no condensation
Operating altitude	During operation	≤ 2,000 m above sea level at max. 56 °C ambient temperature
		≤ 3,000 m above sea level at max. 50 °C ambient temperature

**Design, dimensions and weight**

Immunity to interference	EN 61000-6-2	
Emission	EN 61000-6-3	
Degree of protection	IP 30	
MTBF (EN/IEC 61709, 40 °C)	49.3 years	
Housing material	Basic housing	Die cast aluminum, powder coated
	Front cover	Polyphenylene ether + polystyrene (PPE+PS plastic)
Weight	1500 g	
Dimensions (W x H x D)	180 x 125 x 124 mm	
Installation options	<ul style="list-style-type: none"> <li>• Installation on a DIN rail</li> <li>• Installation on an S7-300 standard rail</li> <li>• Wall mounting</li> </ul>	

**Switching properties**

Aging time	30 seconds
Max. number of learnable MAC addresses	2048
Response to LLDP frames	Blocking
Response to spanning tree BPDU frames	Forwarding

---

**Technical specifications**

---

CoS acc. to IEEE 802.1Q	Yes
QoS priority queues	4

---

---

**Note**

The number of SCALANCE X Industrial Ethernet switches connected in a line influences the frame delay time.

When a frame passes through devices of the SCALANCE X-100 product line, it is delayed by the store and forward function of the switch

- with a 64 byte frame length by approx. 10 microseconds (at 100 Mbps)
- with a 1500 byte frame length by approx. 130 microseconds (at 100 Mbps)

This means that the more devices of the SCALANCE X-100 product line, the frame passes through, the longer the frame delay.

---

---

**Note**

**Temperature code for c-UL-us for hazardous locations, FM and ATEX Zone 2**

You will find the temperature code "T.." or the maximum ambient temperature "Ta: .." on the type plate.

---

## 7.8 Mechanical stability (in operation)

### Mechanical stability (in operation)

Device	DIN EN 60068-2-6 oscillation	DIN EN 60068-2-6 oscillation	DIN EN 60068-2-6 oscillation	DIN EN 60068-2-29 permanent shock	DIN EN 60068-2-29 permanent shock
	10 - 58 Hz: 0.075 mm 58 - 500 Hz: 10 m/s <sup>2</sup> 10 cycles	10 - 58 Hz: 0.15 mm 58 - 500 Hz: 20 m/s <sup>2</sup> 10 cycles	5 - 8.51 Hz: 3.5 mm 8.51 - 500 Hz: 10 m/s <sup>2</sup> 10 cycles	100 m/s <sup>2</sup> , 16 ms duration 100 shocks per axis	250 m/s <sup>2</sup> , 6 ms duration 1000 shocks per axis
X104-2	•	•	•	•	•
X106-1	•	•	•	•	•
X108	•	•	•	•	•

Device	DIN EN 60068-2-6 vibration	DIN EN 60068-2-6 vibration	DIN EN 60068-2-6 vibration	DIN EN 60068-2-6 vibration ship building	DIN EN 60068-2-27 shock	DIN EN 60068-2-29 permanent shock	DIN EN 60068-2-29 permanent shock
	2 - 13.2 Hz: 2.0 mm <sup>PP</sup> 13.2 - 100 Hz: 7 m/s <sup>2</sup> 1 sweep	5 - 8.51 Hz: 7.0 mm <sup>PP</sup> 8.51 - 500 Hz: 10 m/s <sup>2</sup> 1 oct/min, 20 sweeps	5 - 8.51 Hz: 7.0 mm <sup>PP</sup> 8.51 - 150 Hz: 10 m/s <sup>2</sup> 1 oct/min, 10 cycles	2 - 25 Hz: 3.2 mm <sup>PP</sup> 25 - 100 Hz: 40 m/s <sup>2</sup> 1 sweep	150 m/s <sup>2</sup> , 11 ms duration 6 shocks per axis	250 m/s <sup>2</sup> , 6 ms duration 1000 shocks per axis	100 m/s <sup>2</sup> , 16 ms duration 100 shocks per axis
X108PoE	•	•	•	•	•	•	•

Device	DIN EN 60068-2-6 oscillation	DIN EN 60068-2-27 shock
	5 - 8.51 Hz: 3.5 mm 8.51 - 500 Hz: 10 m/s <sup>2</sup> 1 oct/min, 10 cycles	150 m/s <sup>2</sup> , 16 ms duration 6 shocks per axis
X112-2	•	•
X116	•	•
X124	•	•



# Certifications and approvals

The SIMATIC NET products described in these Operating Instructions have the approvals listed below.

---

## Note

### Issued approvals on the type plate of the device

The specified approvals apply only when the corresponding mark is printed on the product. You can check which of the following approvals have been granted for your product by the markings on the type plate.

---

## Current approvals on the Internet

You will find the current approvals for the product on the Internet pages of Siemens Industry Online Support (<https://support.industry.siemens.com/cs/ww/en/ps/15273/cert>).

## Notes for the manufacturers of machines

The devices are not machines in the sense of the EC Machinery Directive. There is therefore no declaration of conformity relating to the EC Machinery Directive 2006/42/EC for these devices.

If the devices are part of the equipment of a machine, they must be included in the declaration of conformity procedure by the manufacturer of the machine.

## See also

SIMATIC NET Industrial Ethernet TP and Fiber Optic Networks  
(<http://support.automation.siemens.com/WW/view/en/8763736>)

## Installation guidelines

The devices meet the requirements if you adhere to the installation and safety instructions contained in this documentation and in the following documentation when installing and operating the devices.

- "Industrial Ethernet / PROFINET Industrial Ethernet" System Manual
- "Industrial Ethernet / PROFINET - Passive network components" System Manual

You will find information on the system manuals in the section "AUTOHOTSPOT", in "Further documentation".

- "EMC Installation Guidelines" configuration manual  
60612658 (<http://support.automation.siemens.com/WW/view/en/60612658>)

 <b>WARNING</b>
<b>Personal injury and property damage can occur</b>
The installation of expansions that are not approved for SIMATIC NET products or their target systems may violate the requirements and regulations for safety and electromagnetic compatibility.
Only use expansions that are approved for the system.

**Note**

The test was performed with a device and a connected communications partner that also meets the requirements of the standards listed above.

When operating the device with a communications partner that does not comply with these standards, adherence to the corresponding values cannot be guaranteed.

## 8.1 EU declaration of conformity



The EC Declaration of Conformity is available for all responsible authorities at:

Siemens Aktiengesellschaft  
Process Industries and Drives Division  
Process Automation  
DE-76181 Karlsruhe  
Germany

You will find the EC declaration of conformity for these products on the Internet pages of Siemens Industry Online Support (<https://support.industry.siemens.com/cs/ww/en/ps/15273/cert>).

The SIMATIC NET products described in these Operating Instructions meet the requirements of the following EC directives:

- 94/9/EC  
ATEX directive of the European Parliament and the Council of 23 March 1994 on the approximation of the laws of the Member States concerning equipment and protective systems intended for use in potentially explosive atmospheres (until 19.04.2016).
- 2014/34/EU  
ATEX directive of the European Parliament and the Council of 26 February 2014 on the approximation of the laws of the member states concerning equipment and protective systems intended for use in potentially explosive atmospheres (as of 20.04.2016).

- 2004/108/EC (EMC up to 19.04.2016)  
EMC directive of the European Parliament and of the Council of December 15, 2004 on the approximation of the laws of the member states relating to electromagnetic compatibility.
- 2014/30/EC (EMC, as of 20.04.2016)  
EMC directive of the European Parliament and of the Council of February 26, 2014 on the harmonization of the laws of the member states relating to electromagnetic compatibility.
- 2011/65/EU (RoHS)  
RoHS directive of the European Parliament and of the Council of 8 June 2011 on the restriction of the use of certain hazardous substances in electrical and electronic equipment.

The current versions of the standards can be seen in the EC Declaration of Conformity.

### See also

Products (Page 65)

## 8.1.1 ATEX

### ATEX directive (correct usage in potentially explosive atmospheres)

The SIMATIC NET product meets the requirements of the EC directives:94/9/EC (until 19.04.2016) and 2014/34/EU (as of 20.04.2016) "Equipment and Protective Devices for Use in Potentially Explosive Atmospheres".

Applied standard:

- EN 60079-0  
Hazardous areas - Part 0: Equipment - General requirements
- EN 60079-15  
Explosive atmospheres - Part 15: Device protection by type of protection

### See also

Products (Page 65)

## 8.1.2 EMC

### EMC directive (electromagnetic compatibility)

The SIMATIC NET products described in these operating instructions meet the requirements of EC directive 2004/108/EC (until 19.04.2016) and 2014/30/EU (as of 20.04.2016) "Electromagnetic Compatibility" for the following areas of application:

Applied standards:

- EN 61000-6-1  
Electromagnetic compatibility (EMC) - Part 6-1: Generic standards - Immunity for residential, commercial and light-industrial environments
- EN 61000-6-2  
Electromagnetic compatibility (EMC) - Part 6-2: Generic standards - Immunity for industrial environments.
- EN 61000-6-3  
Electromagnetic compatibility (EMC) - Part 6-3: Generic standards - Emission standard for residential, commercial and light-industrial environments.
- EN 61000-6-4  
Electromagnetic compatibility (EMC) - Part 6-4: Generic standards - Emission standard for industrial environments.

### See also

Products (Page 65)

## 8.1.3 RoHS

### RoHS directive (restriction of the use of certain hazardous substances)

The SIMATIC NET products described in these operating instructions meet the requirements of the EC directive 2011/65/EC for the restriction of the use of certain hazardous substances in electrical and electronic equipment:

Applied standard:

- 3 EN 50581  
Technical documentation for the assessment electrical and electronic products with respect to restriction of hazardous substances



## 8.1.4 Products

### Product designation and standards

The standards that apply to the product are described in EMC (Page 64) and RoHS (Page 64).

Product name	Standards
SCALANCE X104-2	1, 2, 4, 6, 7
SCALANCE X106-1	1, 2, 4, 6, 7
SCALANCE X108	1, 2, 4, 6, 7
SCALANCE X108PoE	1, 2, 4, 6, 7
SCALANCE X112-2	1, 2, 4, 6, 7
SCALANCE X116	1, 2, 4, 6, 7
SCALANCE X124	1, 2, 4, 6, 7

## 8.2 ATEX (KEMA 07 ATEX0145 X)

### ATEX (explosion protection directive)

 <b>WARNING</b>
<p>When using SIMATIC NET products in hazardous area zone 2, make absolutely sure that the associated conditions in the following document are adhered to:</p> <p>"SIMATIC NET Product Information Use of subassemblies/modules in a Zone 2 Hazardous Area".</p> <p>You will find this document</p> <ul style="list-style-type: none"><li>• on the data medium that ships with some devices.</li><li>• on the Internet pages of Siemens Industry Online Support (<a href="http://support.automation.siemens.com/WWW/view/en">http://support.automation.siemens.com/WWW/view/en</a>).</li></ul> <p>Enter the document identification number C234 as the search term.</p>

The SIMATIC NET products meet the requirements of the EC directive 94/9/EC "Equipment and Protective Devices for Use in Potentially Explosive Atmospheres". and as of 20.04.2016 the EC directive 2014/34/EU.

ATEX classification:

II 3 G Ex nA IIC T4 Gc

KEMA 07ATEX0145 X

The products meet the requirements of the following standards:

- EN 60079-15 (electrical apparatus for potentially explosive atmospheres; Type of protection "n")
- EN 60079-0 (Explosive atmospheres - Part 0: Equipment - General requirements)

You will find the current versions of the standards in the currently valid ATEX certificates.

## IECEX

The SIMATIC NET products meet the requirements of explosion protection according to IECEX.

IECEX classification:

Ex nA IIC T4 Gc

DEK 14.0025X

The products meet the requirements of the following standards:

- IEC 60079-15 (Explosive atmospheres - Part 15: Equipment protection by type of protection "n")
- IEC 60079-0 (Explosive atmospheres - Part 0: Equipment - General requirements)

You will find the current versions of the standards in the currently valid IECEX certificates.

## FM

The product meets the requirements of the standards:

- Factory Mutual Approval Standard Class Number 3611
- FM Hazardous (Classified) Location Electrical Equipment:  
Non Incendive / Class I / Division 2 / Groups A,B,C,D / T4 and  
Non Incendive / Class I / Zone 2 / Group IIC / T4

## cULus Approval for Information Technology Equipment

cULus Listed I. T. E.

Underwriters Laboratories Inc. complying with

- UL 60950-1 (Information Technology Equipment)
- CSA C22.2 No. 60950-1-03

Report no. E115352

### **cULus Approval Hazardous Location**

cULus Listed I. T. E. FOR HAZ. LOC.

Underwriters Laboratories Inc. complying with

- UL 60950-1 (Information Technology Equipment)
- ANSI/ISA 12.12.01-2007
- CSA C22.2 No. 213-M1987

Approved for use in  
Cl. 1, Div. 2, GP A, B, C, D T4  
Cl. 1, Zone 2, GP IIC T4

Report no. E240480

### **E1**

The SCALANCE X108 switch meets the requirements of the directive ECE-G 95/54/EC.

Test number 10 R - 034734

### **e1**

The SCALANCE X108 IE switch meets the requirements of the Directive 72/245/EEC in the form 2006/96/EC "Electromagnetic Compatibility".

Test number 03 4734

### **RCM**

The product meets the requirements of the AS/NZS 2064 standard (Class A).

### **Marking for the customs union**



EAC (Eurasian Conformity)

Customs union of Russia, Belarus and Kazakhstan

Declaration of the conformity according to the technical regulations of the customs union (TR CU)



# Dimension drawings

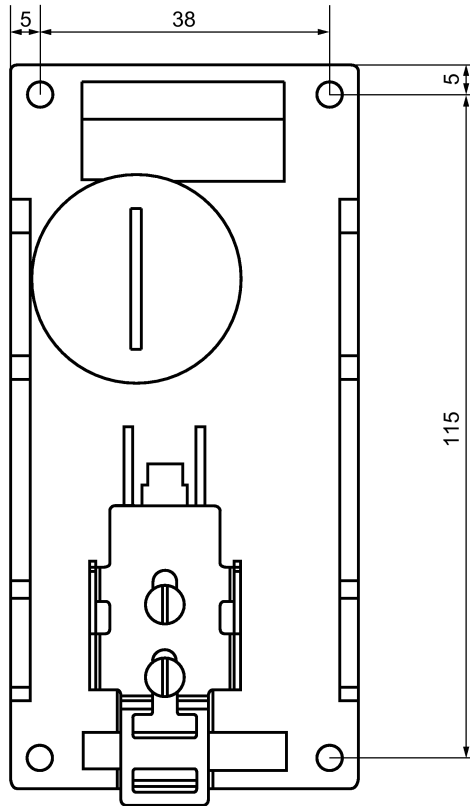

Figure 9-1 Dimension drawing, rear of the SCALANCE X104-2, X106-1, X108, X108PoE

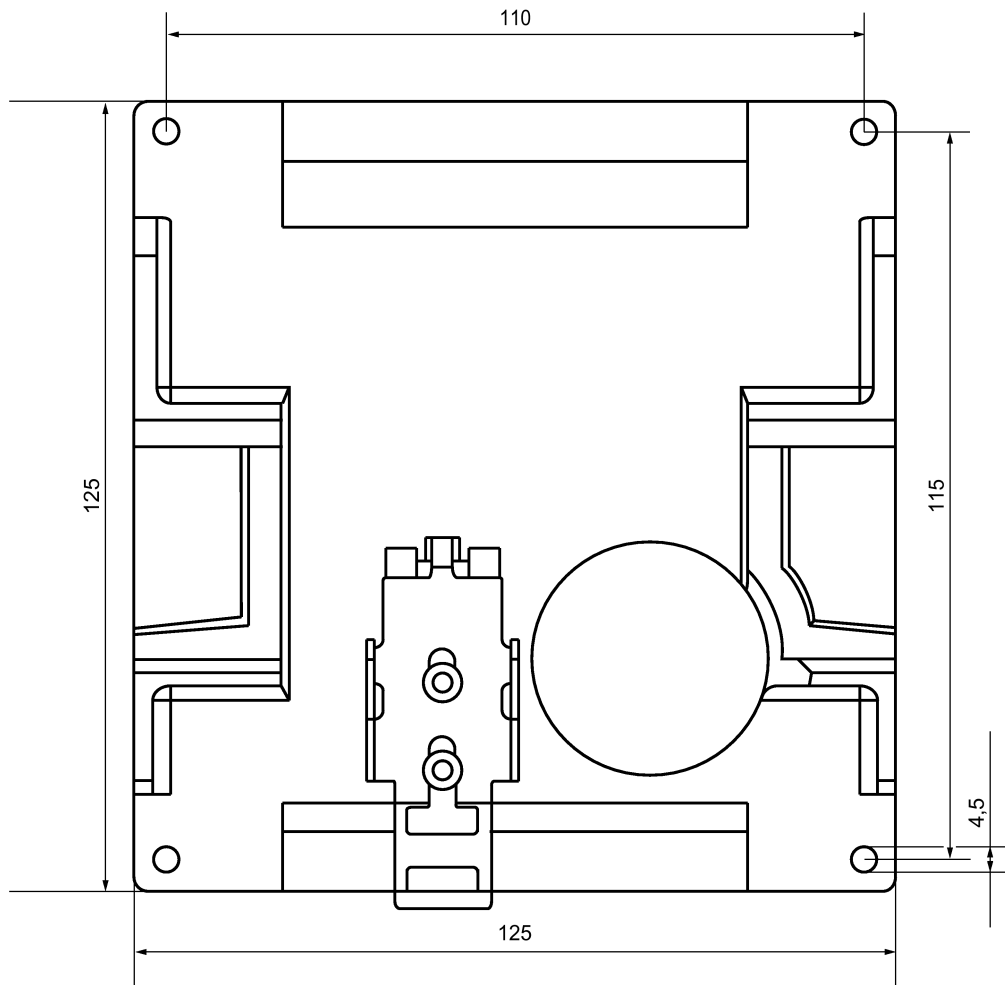

Figure 9-2 Dimension drawing, rear of the SCALANCE X116, X112-2

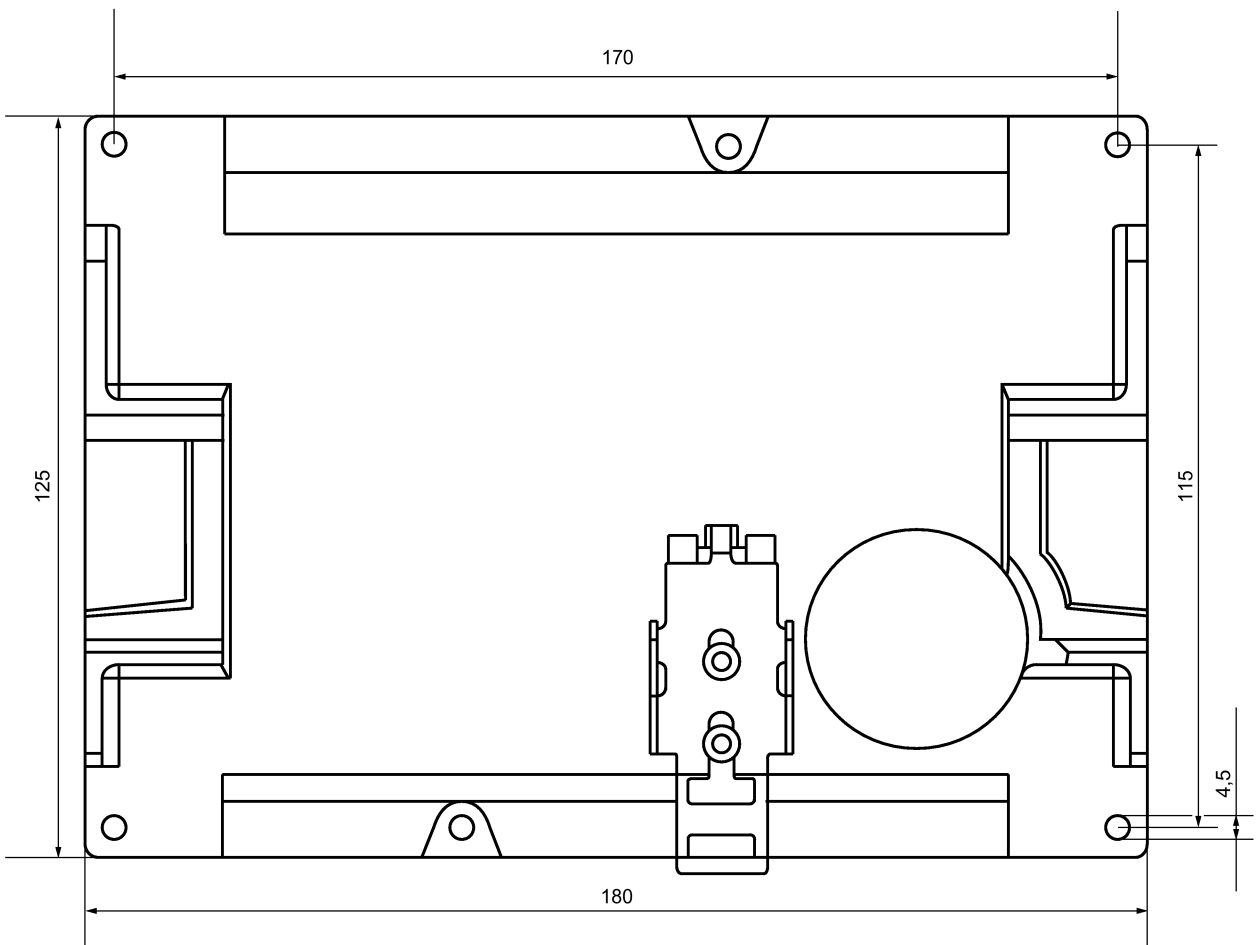

Figure 9-3 Dimension drawing, rear of the SCALANCE X124

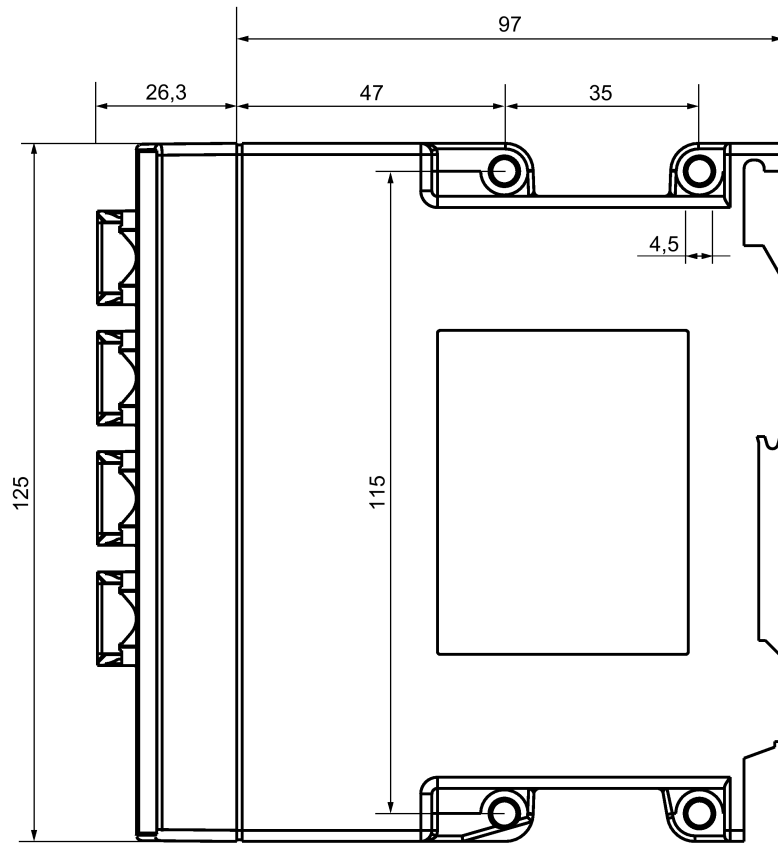

Figure 9-4 Dimension drawing, side view



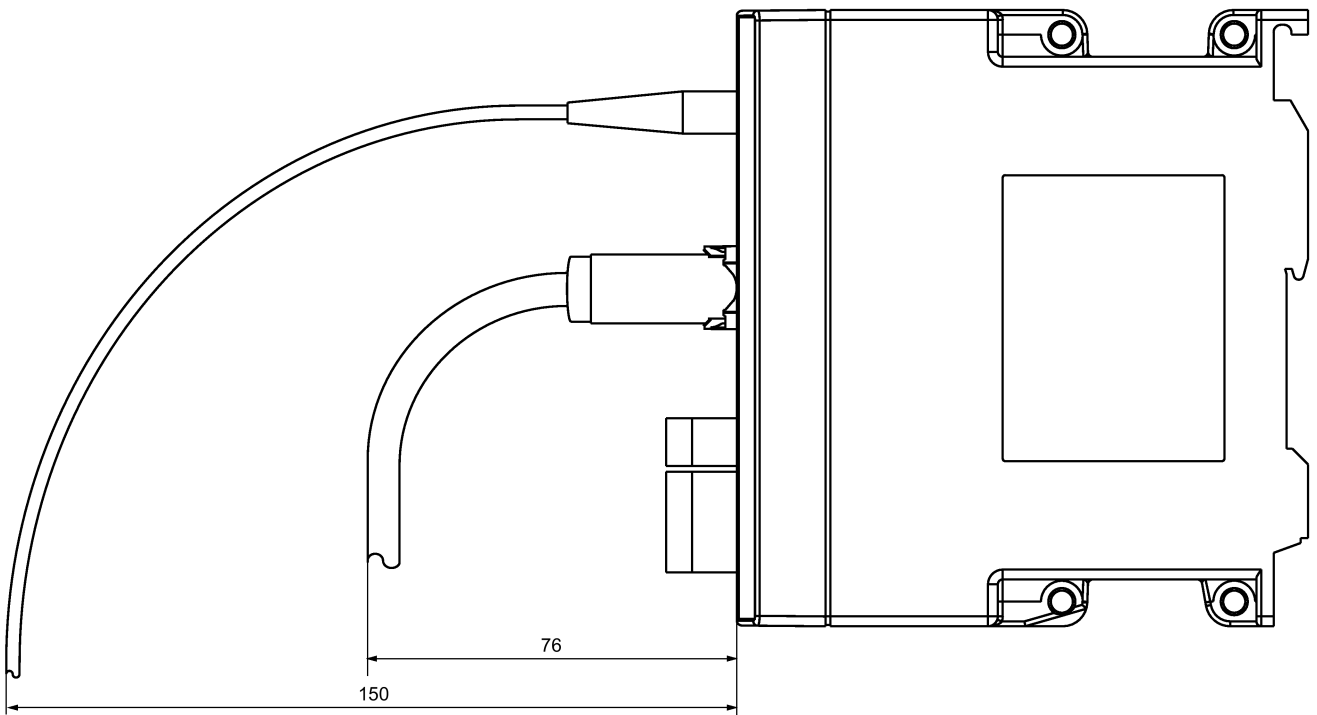

Figure 9-5 Dimension drawing, bending radii



# Index

## A

- Accessories, 8
- Approvals, 61
- Auto polarity exchange, 22
- Autonegotiation, 22

## B

- Bending radii, 73
- BFOC socket
  - ST socket, 15

## C

- CE mark, 61
- Components of the product, 8
- Connection to Industrial Ethernet, 43, 45, 48, 50, 52, 54, 56
- Connector pinout, 21
  - SCALANCE X108 PoE, 21

## D

- Design, dimensions and weight, 44, 46, 49, 51, 53, 55, 57
- Dimension drawing, 69
- Display, 41, 41
- Drilled holes, 72

## E

- e1, 67
- E1, 67
- Electrical data, 44, 46, 48, 50, 53, 55, 57
- Error
  - Far-end fault, 41
  - LED display when voltage drops, 41
  - Link display, 41
- ESD directives, 9

## F

- Fault mask
  - Changing the setting, 25
  - Error/fault, 26
  - Factory setting, 25
- FO port, 23
- Further documentation, 5

## G

- Glossary, 6
- Grounding, 39
  - Installation on a DIN rail, 39
  - S7 standard rail, 39
  - Wall mounting, 39

## I

- IE FC RJ-45 Plug 180, 39
  - Installation, 39
  - Plugging in, 40
  - Pulling, 40
- Installation
  - Installation on a DIN rail, 29
  - Installation on a standard rail, 31
  - Types of installation, 29

## L

- LEDs, 24
  - Fault LED (red LED), 24
  - Port LEDs (green/yellow LEDs), 24
  - Power LED (green LED), 24

## M

- MDI / MDI-X autocrossover function, 22

## N

- Network topology, 11
  - Electrical star topology, 11
  - Electrical/optical star topology, 12

**O**

Optical connectors, 43, 45, 52  
Optical parameters, 43, 46, 52  
Order numbers, 43, 45, 48, 50, 52, 54, 56

**P**

Permitted ambient conditions, 44, 46, 48, 50, 53, 55, 57  
Permitted cable lengths, 22, 43, 45, 48, 50, 52, 54, 56  
Possible attachments  
    SCALANCE X108, 16  
Possible connections  
    SCALANCE X104-2, 14  
    SCALANCE X106-1, 15  
    SCALANCE X108PoE, 17  
    SCALANCE X112-2, 18  
    SCALANCE X116, 19  
    SCALANCE X124, 20  
Power over Ethernet (PoE) function, 17  
Power supply, 37  
Product properties, 13

**R**

Reduced voltage, 41  
RJ-45, 21

**S**

Safety notices  
    for installation, 27  
    Use in hazardous areas, 27, 35  
    when connecting up, 35  
SCALANCE X104-2  
    Connection to Industrial Ethernet, 43  
    Design, dimensions and weight, 44  
    Electrical data, 44  
    Optical connectors, 43  
    Optical parameters, 43  
    Order numbers, 43  
    Permitted ambient conditions, 44  
    Permitted cable lengths, 43  
    Switching properties, 44  
SCALANCE X106-1  
    Connection to Industrial Ethernet, 45  
    Design, dimensions and weight, 46  
    Electrical data, 46  
    Optical connectors, 45  
    Optical parameters, 46

Order numbers, 45  
Permitted ambient conditions, 46  
Permitted cable lengths, 45  
Switching properties, 47

**SCALANCE X108**

Connection to Industrial Ethernet, 48  
Design, dimensions and weight, 49  
Electrical data, 48  
Order numbers, 48  
Permitted ambient conditions, 48  
Permitted cable lengths, 48  
Switching properties, 49

**SCALANCE X108PoE**

Connection to Industrial Ethernet, 50  
Design, dimensions and weight, 51  
Electrical data, 50  
Order numbers, 50  
Permitted ambient conditions, 50  
Permitted cable lengths, 50  
PoE properties, 51  
Switching properties, 51

**SCALANCE X112-2**

Connection to Industrial Ethernet, 52  
Design, dimensions and weight, 53  
Electrical data, 53  
Optical connectors, 52  
Optical parameters, 52  
Order numbers, 52  
Permitted ambient conditions, 53  
Permitted cable lengths, 52  
Switching properties, 53

**SCALANCE X116**

Connection to Industrial Ethernet, 54  
Design, dimensions and weight, 55  
Electrical data, 55  
Order numbers, 54  
Permitted ambient conditions, 55  
Permitted cable lengths, 54  
Switching properties, 55

**SCALANCE X124**

Connection to Industrial Ethernet, 56  
Design, dimensions and weight, 57  
Electrical data, 57  
Order numbers, 56  
Permitted ambient conditions, 57  
Permitted cable lengths, 56  
Switching properties, 57

**SET button, 25**

Function, 25

**Side view, 72****Signaling contact, 38****SIMATIC NET glossary, 6**

ST socket

    BFOC socket, 14

Switching properties, 44, 47, 49, 51, 51, 53, 55, 57

System manual, 29, 61

## **T**

Technical specifications, 43, 45, 48, 50, 52, 54, 56

    SCALANCE X104-2, 43

    SCALANCE X106-1, 45

    SCALANCE X108, 48

    SCALANCE X108PoE, 50

    SCALANCE X112-2, 52

    SCALANCE X116, 54

    SCALANCE X124, 56

TP ports, 21

