

SIEMENS

SIMATIC NET

Industrial Ethernet switches SCALANCE X-100 media converter



Operating Instructions

<u>Introduction</u>	1
<u>Network topologies</u>	2
<u>Description of the device</u>	3
<u>Installation</u>	4
<u>Connecting up</u>	5
<u>Maintenance</u>	6
<u>Technical specifications</u>	7
<u>Approvals</u>	8
<u>Dimension drawings</u>	9

Legal information

Warning notice system

This manual contains notices you have to observe in order to ensure your personal safety, as well as to prevent damage to property. The notices referring to your personal safety are highlighted in the manual by a safety alert symbol, notices referring only to property damage have no safety alert symbol. These notices shown below are graded according to the degree of danger.

 DANGER
indicates that death or severe personal injury will result if proper precautions are not taken.
 WARNING
indicates that death or severe personal injury may result if proper precautions are not taken.
 CAUTION
indicates that minor personal injury can result if proper precautions are not taken.
NOTICE
indicates that property damage can result if proper precautions are not taken.

If more than one degree of danger is present, the warning notice representing the highest degree of danger will be used. A notice warning of injury to persons with a safety alert symbol may also include a warning relating to property damage.

Qualified Personnel

The product/system described in this documentation may be operated only by **personnel qualified** for the specific task in accordance with the relevant documentation, in particular its warning notices and safety instructions. Qualified personnel are those who, based on their training and experience, are capable of identifying risks and avoiding potential hazards when working with these products/systems.

Proper use of Siemens products

Note the following:

 WARNING
Siemens products may only be used for the applications described in the catalog and in the relevant technical documentation. If products and components from other manufacturers are used, these must be recommended or approved by Siemens. Proper transport, storage, installation, assembly, commissioning, operation and maintenance are required to ensure that the products operate safely and without any problems. The permissible ambient conditions must be complied with. The information in the relevant documentation must be observed.

Trademarks

All names identified by ® are registered trademarks of Siemens AG. The remaining trademarks in this publication may be trademarks whose use by third parties for their own purposes could violate the rights of the owner.

Disclaimer of Liability

We have reviewed the contents of this publication to ensure consistency with the hardware and software described. Since variance cannot be precluded entirely, we cannot guarantee full consistency. However, the information in this publication is reviewed regularly and any necessary corrections are included in subsequent editions.

Table of contents

1	Introduction	5
1.1	On the Operating Instructions	5
1.2	On the product	7
2	Network topologies	11
2.1	Possible network topologies	11
2.2	Coupling of network segments.....	14
3	Description of the device	17
3.1	Overview of the SCALANCE X-100 media converters	17
3.2	Product characteristics.....	18
3.2.1	SCALANCE X101-1	18
3.2.2	SCALANCE X101-1FL	19
3.2.3	SCALANCE X101-1LD	20
3.2.4	SCALANCE X101-1POF.....	21
3.2.5	SCALANCE X101-1AUI	22
3.3	TP ports (twisted pair).....	23
3.4	FO port (fiber optic).....	25
3.4.1	SCALANCE X101-1	25
3.4.2	SCALANCE X101-1FL.....	26
3.4.3	SCALANCE X101-1LD	27
3.4.4	SCALANCE X101-1POF.....	28
3.5	AUI port (Attachment Unit Interface).....	29
3.6	LEDs	31
3.7	SET button	33
3.8	Cascading two media converters.....	35
4	Installation	37
4.1	Types of installation	37
4.2	Installation on a DIN rail.....	38
4.3	Installation on a standard rail.....	40
4.4	Wall mounting	41
5	Connecting up	43
5.1	Power supply.....	43
5.2	Signaling contact.....	45
5.3	Grounding	46
5.4	IE FC RJ-45 Plug 180	46

5.5	AUI cable.....	48
6	Maintenance	49
7	Technical specifications	51
7.1	SCALANCE X101-1	51
7.2	SCALANCE X101-1FL.....	54
7.3	SCALANCE X101-1LD.....	57
7.4	SCALANCE X101-1POF.....	60
7.5	SCALANCE X101-1AUI	63
8	Approvals	65
9	Dimension drawings.....	69
	Index	73

Introduction

1.1 On the Operating Instructions

Purpose of the Operating Instructions

These operating instructions support you when commissioning networks with the media converters of the SCALANCE X-100.

Validity of the Operating Instructions

These operating instructions are valid for the following devices:

Device	Order number
SCALANCE X101-1	6GK5101-1BB00-2AA3
SCALANCE X101-1FL	6GK5101-1BY00-2AA3
SCALANCE X101-1LD	6GK5101-1BC00-2AA3
SCALANCE X101-1POF	6GK5101-1BH00-2AA3
SCALANCE X101-1AUI	6GK5101-1BX00-2AA3

Further documentation

The "SIMATIC NET Industrial Ethernet Twisted Pair and Fiber Optic Networks" manual contains additional information on other SIMATIC NET products that you can operate along with the media converters of the SCALANCE X-100 product line in an Industrial Ethernet network.

You can order the manual "SIMATIC NET Industrial Twisted Pair and Fiber Optic Networks", release 05/2001, using the following order numbers:

6GK1970-1BA10-0AA0 German

6GK1970-1BA10-0AA1 English

6GK1970-1BA10-0AA2 French

6GK1970-1BA10-0AA4 Italian

You will also find this network manual on the Internet pages of Service & Support under the following entry ID: 1172207 (<http://support.automation.siemens.com/WW/view/en/1172207>).

You will find further information in the "System Manual Industrial Ethernet" in the Manual Collection.

You will find further information on the SCALANCE system on the Internet at www.siemens.com/scalance (www.siemens.com/scalance).

You can obtain the "PROFINET Installation Guide" from the PROFIBUS User Organization (PNO).

Audience

These Operating Instructions are intended for persons commissioning networks with SCALANCE X-100 media converters.

SIMATIC NET glossary

Explanations of many of the specialist terms used in this documentation can be found in the SIMATIC NET glossary.

You will find the SIMATIC NET glossary here:

- SIMATIC NET Manual Collection or product DVD
The DVD ships with certain SIMATIC NET products.
- On the Internet under the following entry ID:
50305045 (<http://support.automation.siemens.com/WW/view/en/50305045>)

Security information

Siemens provides products and solutions with industrial security functions that support the secure operation of plants, solutions, machines, equipment and/or networks. They are important components in a holistic industrial security concept. With this in mind, Siemens' products and solutions undergo continuous development. Siemens recommends strongly that you regularly check for product updates.

For the secure operation of Siemens products and solutions, it is necessary to take suitable preventive action (e.g. cell protection concept) and integrate each component into a holistic, state-of-the-art industrial security concept. Third-party products that may be in use should also be considered. For more information about industrial security, visit <http://www.siemens.com/industrialsecurity>.

To stay informed about product updates as they occur, sign up for a product-specific newsletter. For more information, visit <http://support.automation.siemens.com>.

1.2 On the product

What is possible?

The media converters of the SCALANCE X-100 allow the cost-effective installation of Industrial Ethernet linear (bus) and star structures with transitions from one media to another.

The passive use of two identical SCALANCE X-100 media converters in series (cascaded) within a redundant ring is possible. In this case, the media converters behave "like a section of cable". A simple, passive coupling of two rings is also possible. See also "Coupling of network segments (Page 14)".

Note

Note that direct cascading of two media converters SCALANCE X101-1FL or SCALANCE X101-1AUI is not possible.

Note

If devices are supplied over long 24 V power supply lines or networks, measures are necessary to prevent interference by strong electromagnetic pulses on the supply lines. These can result, for example, due to lightning or switching of large inductive loads.

One of the tests used to attest the immunity of these devices to electromagnetic interference is the "surge immunity test" according to EN 61000-4-5. This test requires overvoltage protection for the power supply lines. A suitable device is, for example, the Dehn Blitzductor BVT AVD 24 V type no. 918 422 or a comparable protective element.

Manufacturer:

DEHN+SÖHNE GmbH+Co.KG Hans Dehn Str.1 Postfach 1640 D-92306 Neumarkt, Germany

 WARNING
--

When used in hazardous environments corresponding to Class I, Division 2 or Class I, Zone 2, the device must be installed in a cabinet or a suitable enclosure.

 WARNING
--

To comply with EU Directive 94/9 (ATEX95), this enclosure must meet the requirements of at least IP54 in compliance with EN 60529.
--

 WARNING
--

EXPLOSION HAZARD

DO NOT CONNECT OR DISCONNECT EQUIPMENT WHEN A FLAMMABLE OR COMBUSTIBLE ATMOSPHERE IS PRESENT.

Scope of delivery

The following components are supplied with a SCALANCE X-100 media converter:

- SCALANCE X-100 media converter
- 2-pin plug-in terminal block (signaling contact)
- 4-terminal plug-in block (power supply)
- Product information

Accessories

Component	Packaging unit	Order number
IE FC Stripping Tool	1	6GK1901-1GA00
IE FC blade cassettes	1	6GK1901-1GB00
IE FC TP standard cable GP	1	6XV1840 2AH10
IE FC TP trailing cable	1	6XV1840-3AH10
IE FC TP marine cable	1	6XV1840-4AH10
IE FC TP trailing cable GP	1	6XV1870-2D
IE FC TP flexible cable GP	1	6XV1870-2B
IE FC RJ-45 Plug 180	1	6GK1 901-1BB10-2AA0
IE FC RJ-45 Plug 180	10	6GK1 901-1BB10-2AB0
IE FC RJ-45 Plug 180	50	6GK1 901-1BB10-2AE0

Unpacking and checking

 WARNING
Do not use any parts that show evidence of damage
If you use damaged parts, there is no guarantee that the device will function according to the specification.
If you use damaged parts, this can lead to the following problems:
<ul style="list-style-type: none">• Injury to persons• Loss of the approvals• Violation of the EMC regulations• Damage to the device and other components
Use only undamaged parts.

1. Make sure that the package is complete.
2. Check all the parts for transport damage.

 **WARNING**

Ambient temperature between 55 °C and 60 °C

If a device is operated in an ambient temperature between 55 °C and 60 °C, the temperature of the device housing may be higher than 70 °C. The device must therefore be installed so that it is only accessible to service personnel or users that are aware of the reason for restricted access and the required safety measures at an ambient temperature of 55 °C to 60 °C.

Network topologies

2.1 Possible network topologies

Switching technology allows extensive networks to be set up with numerous nodes and simplifies network expansion.

Which topologies can be implemented?

Using the media converters of the SCALANCE X-100 product line, you can implement bus and star topologies. It is also possible to link rings and to use two identical media converters in a ring structure. See also "Cascading two media converters (Page 35)".

With the Industrial Ethernet media converter SCALANCE X101-1AUI, a transition between TP and AUI technology can be implemented in bus or star topologies. See also "Coupling of network segments (Page 14)".

Note

Keep to the maximum permitted cable lengths of the devices you are using. You will find the permitted cable lengths in the section "Technical specifications (Page 51)".

Bus topology

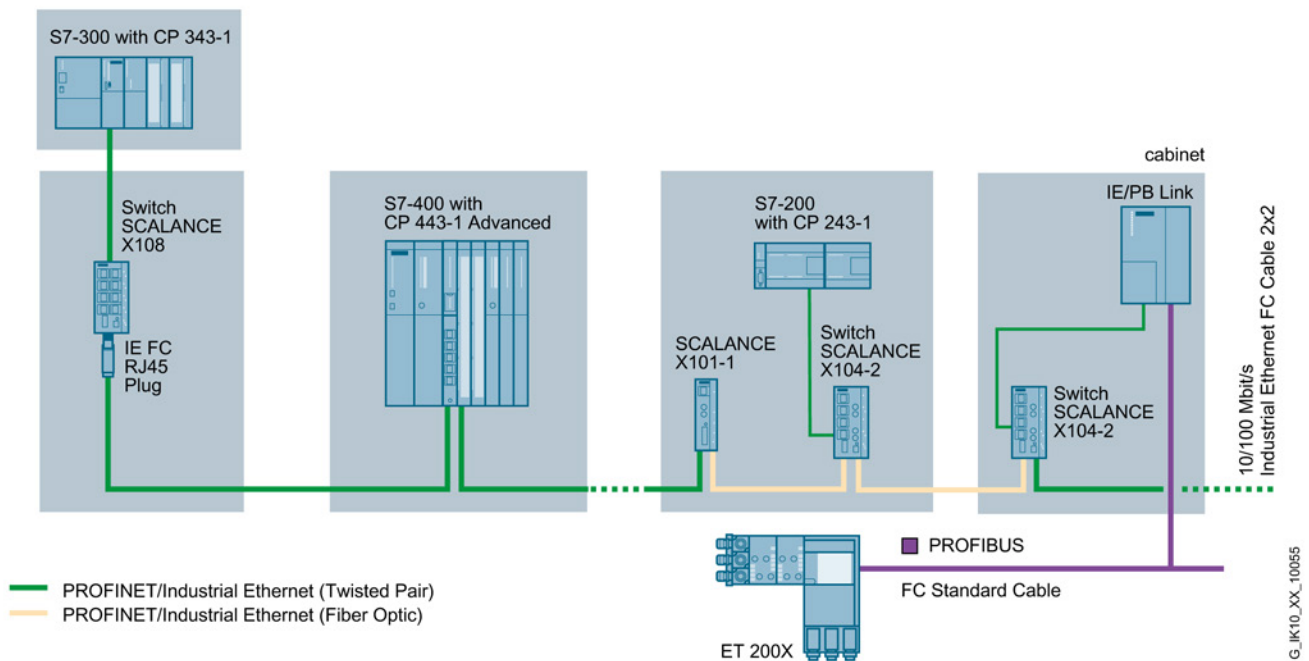

Figure 2-1 Example of an electrical/optical bus topology with SCALANCE X101-1

Note

This setup is possible only with SCALANCE X101-1, SCALANCE X101-1LD or SCALANCE X101-1POF.

Star topology

The following figure shows an optical star structure with the IE switches X-400 and X106-1. A SCALANCE W access point and SIMATIC NET 200 systems are electrically connected via the media converters SCALANCE X101-1 or SCALANCE X101-1LD.

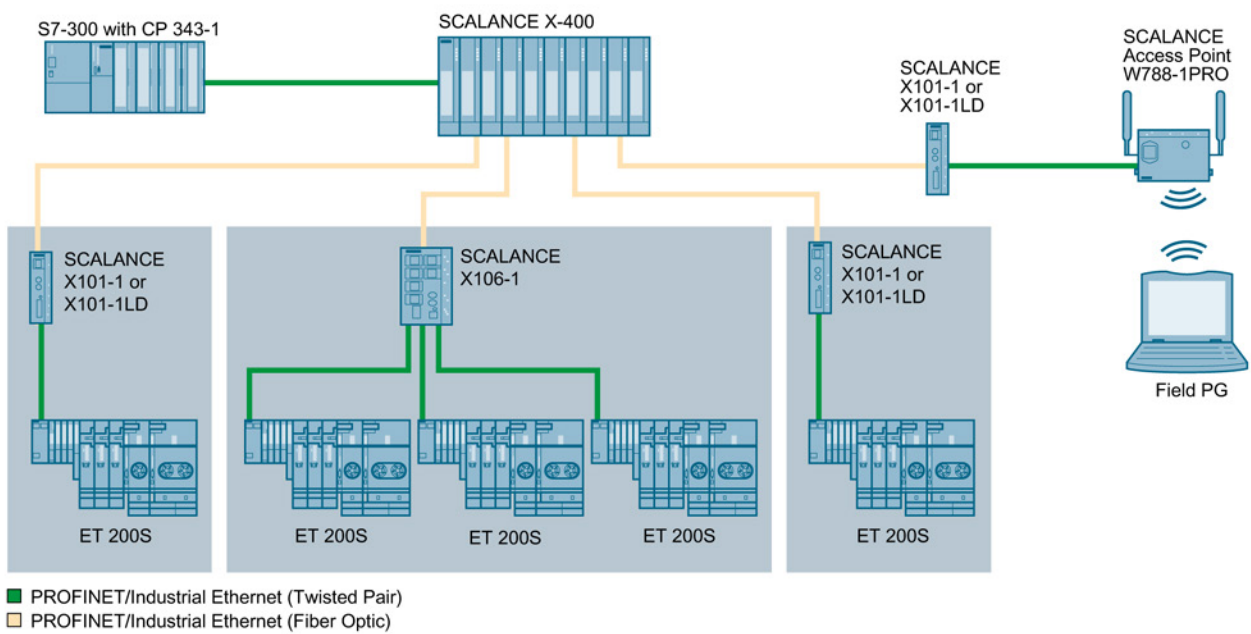

G_IK10_XX_10056

Figure 2-2 Example of an optical star topology with SCALANCE X101-1 or SCALANCE X101-1LD

Ring topology

The following figure shows an electrical ring with a SCALANCE X204IRT as redundancy manager and SCALANCE X208 IE switches. Using the media converters SCALANCE X101-1 or SCALANCE X101-1LD, there is a conversion to an optical section.

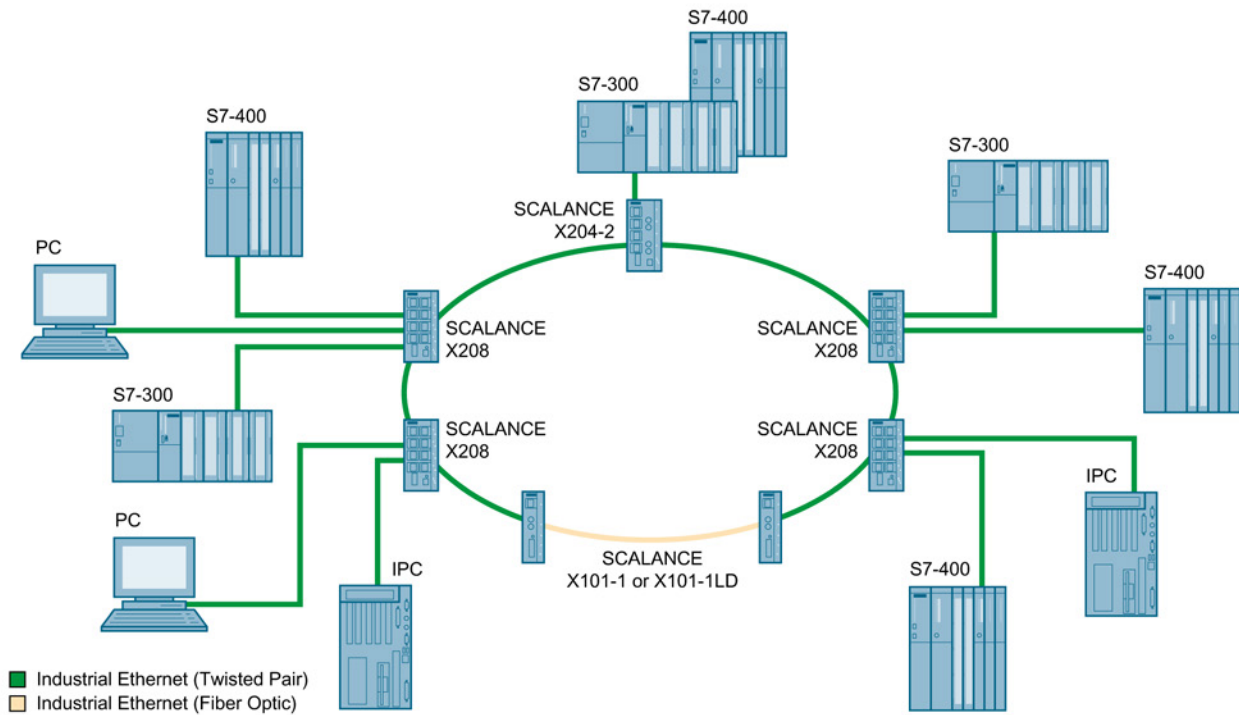

G_JK10_XX_10054

Figure 2-3 Example of an electrical ring with SCALANCE X101-1 or SCALANCE X101-1LD

2.2 Coupling of network segments

The example of a coupling between two ring networks using two SCALANCE X101-1 media converters is only indirectly possible via nodes capable of redundancy (e.g. SCALANCE X-400). This applies to all SCALANCE X-100 media converters.

The following figure shows the standby coupling of two redundant rings using the master/slave concept of the SCALANCE X-400 with SCALANCE X101-1 or SCALANCE X101-1LD media converters.

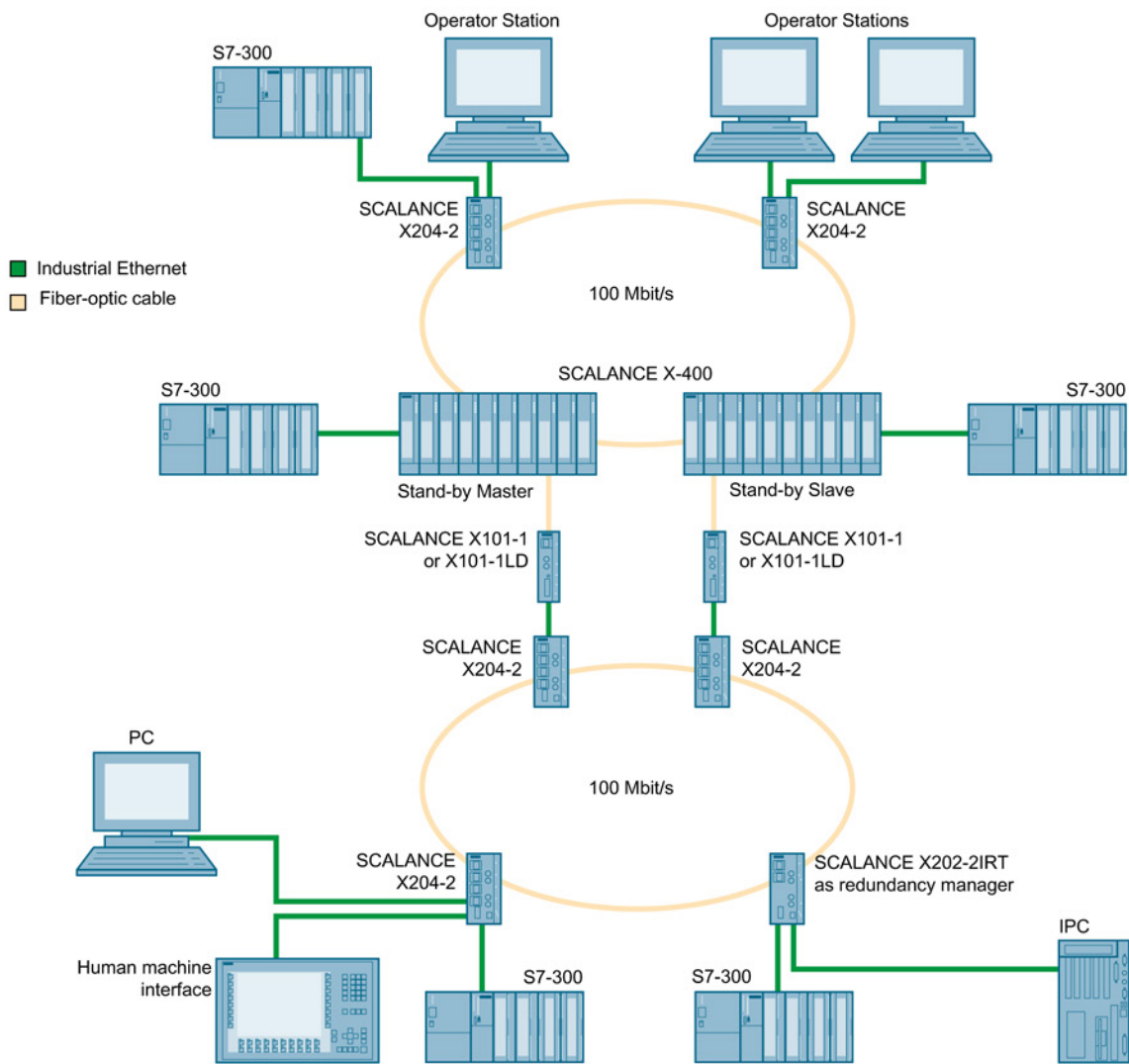

G_JK10_XX_10047

Figure 2-4 Example of a standby coupling of two redundant rings

The example of a coupling shown here illustrates the connection of an IE switch SCALANCE X108 to an existing 10Base5 segment via a SCALANCE X101-1AUI.

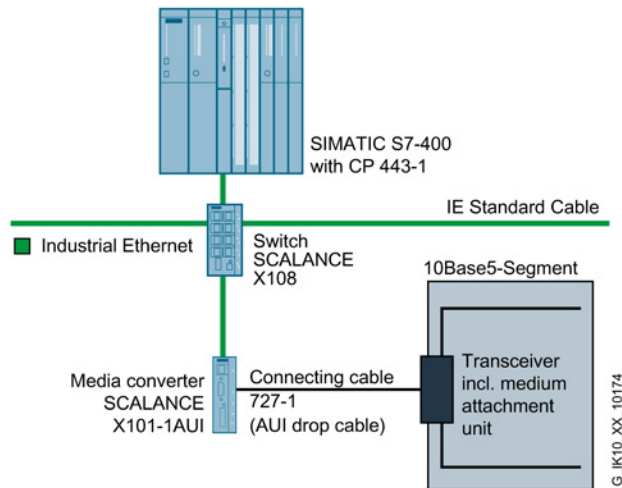

Figure 2-5 Example of a coupling via a repeater

Note

Repeater rule

The SCALANCE X101-1AUI represents a repeater. This must be taken into account when connecting up and designing the network topology.

Description of the device

3.1 Overview of the SCALANCE X-100 media converters

Table 3- 1 Overview of the product characteristics

Properties	X101-1	X101-1FL	X101-1LD	X101-1POF	X101-1AUI
SIMATIC environment	+	+	+	+	+
Diagnostics LED	+	+	+	+	+
24 VDC	+	+	+	+	+
2 x 24 VDC	+	+	+	+	+
Compact housing 40 mm (securing collar, etc.)	+	+	+	+	+
Signaling contact + on-site operation	+	+	+	+	+
Medium Attachment Unit (MAU) – supply with 12 V	-	-	-	-	+
Diagnostics: Web, SNMP, PROFINET	-	-	-	-	-
C-PLUG	-	-	-	-	-
Ring redundancy with RM	-	-	-	-	-
Passive ring redundancy	+	+	+	+	-
Standby redundancy	-	-	-	-	+
IRT capability	-	-	-	-	-
Fast learning	-	-	-	-	-
Passive listening	-	-	-	-	-
Log table	-	-	-	-	-
SNTP + SICLOCK	-	-	-	-	-
Cut Through	+	+	+	+	+

Table 3- 2 Overview of the connection options

	X101-1	X101-1FL	X101-1LD	X101-1POF	X101-1AUI
TP (RJ-45) Fast Ethernet 10 / 100 Mbps	1	1	1	1	1
Fiber multimode (BFOC) 1300 nm	1	-	-	-	-
Fiber multimode (BFOC) 820 nm	-	1	-	-	-
Fiber long distance single mode (BFOC) 1310 nm	-	-	1	-	-
Plastic optical fiber (SC-RJ) 650 nm	-	-	-	1	-
Attachment Unit Interface (AUI) to connect a Medium Attachment Unit (MAU)	-	-	-	-	1

3.2 Product characteristics

3.2.1 SCALANCE X101-1

Possible attachments

The SCALANCE X101-1 media converter has an RJ-45 jack and a BFOC socket for connecting end devices or further network segments.

Note

The BFOC socket (Bayonet Fiber Optic Connector) corresponds to the ST socket.



Figure 3-1 SCALANCE X101-1

3.2.2 SCALANCE X101-1FL

Possible attachments

The SCALANCE X101-1FL media converter has an RJ-45 jack for connection of an end device or further network segments and a BFOC socket for connection of an end device.

NOTICE

Series connection not possible

Cascading the SCALANCE X101-1FL with other media converters is not possible.

Note

The BFOC socket (Bayonet Fiber Optic Connector) corresponds to the ST socket.



Figure 3-2 SCALANCE X101-1FL

3.2.3 SCALANCE X101-1LD

Possible attachments

The SCALANCE X101-1LD media converter has an RJ-45 jack and a BFOC socket for connecting end devices or further network segments.

Note

The BFOC socket (Bayonet Fiber Optic Connector) corresponds to the ST socket.



Figure 3-3 SCALANCE X101-1LD

3.2.4 SCALANCE X101-1POF

Possible attachments

The SCALANCE X101-1POF media converter has an RJ-45 jack and an SC-RJ socket for connecting end devices or further network segments.



Figure 3-4 SCALANCE X101-1POF

3.2.5 SCALANCE X101-1AUI

Possible attachments

The SCALANCE X101-1AUI has an RJ-45 jack and a 15-pin D-sub female connector for connecting to an AUI transceiver (MAU, Medium Attachment Unit).

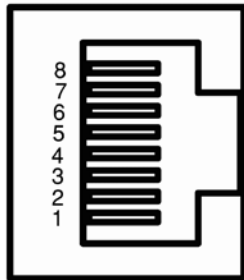

Figure 3-5 SCALANCE X101-1AUI

3.3 TP ports (twisted pair)

RJ-45 connector pinout

With SCALANCE X-100 media converters, the twisted-pair port is designed as an RJ-45 jack with the MDI-X pin assignment (Medium Dependent Interface Autocrossover) of a network component.



Pin number	Assignment
Pin 8	n. c.
Pin 7	n. c.
Pin 6	TD-
Pin 5	n. c.
Pin 4	n. c.
Pin 3	TD+
Pin 2	RD-
Pin 1	RD+

Note

Permitted cable lengths

TP cords or TP-XP cords with a maximum length of 10 m can be connected to the TP port with the RJ-45 jack.

With the IE FC cables and IE FC RJ-45 plugs 180, an overall cable length of a maximum of 100 m is permitted between two devices depending on the cable type.

Autonegotiation

Note

Support of Autonegotiation

The SCALANCE X101-1, SCALANCE X101-1LD and SCALANCE X101-1POF media converters support autonegotiation.

The SCALANCE X101-1FL and SCALANCE X101-1AUI media converters do not support autonegotiation and operate with a fixed transmission mode of 10 Mbps half duplex.

With the autonegotiation mechanism, repeaters and end devices can automatically determine the transmission speed and the transmission mode of the partner port. This makes it possible to configure different devices automatically.

Two components connected to a link segment can exchange information about the data transfer and can adapt their settings to each other. The mode with the highest possible speed is set.

Note

Devices not supporting autonegotiation must be set permanently to 100 Mbps half duplex or 10 Mbps half duplex.

Auto polarity exchange

If the pair of receiving cables is connected incorrectly (RD+ and RD- interchanged), the polarity is adapted automatically.

Note

Auto polarity is not supported by the SCALANCE X101-1FL and SCALANCE X101-1AUI.

MDI / MDI-X autocrossover function

With the MPI/MDI-X autocrossover function, the send and receive contacts of an Ethernet port are assigned automatically. The assignment depends on the cable with which the communications partner is connected. This means that it does not matter whether the port is connected using a patch cable or crossover cable. This prevents malfunctions resulting from mismatching send and receive lines. This makes installation much easier for the user.

The SCALANCE X-100 media converters all support the MDI / MDI-X autocrossover function.

3.4 FO port (fiber optic)

3.4.1 SCALANCE X101-1

Transmission speed

The transmission speed of the optical Fast Ethernet port is 100 Mbps.

Transmission mode

The transmission mode for 100Base-FX is specified in the IEEE 802.3 standard.

Since the full duplex mode and the transmission speed cannot be modified for optical transmission, autonegotiation cannot be used.

Transmission medium

Data transmission is via multimode fiber-optic cable (FO cable). The transceiver wavelength is 1300 nm.

Multimode FO cable is used with a core diameter of 50 or 62.5 μm . The light source is an LED.

The outer diameter of the FO cable is 125 μm .

Range

The maximum transmission range (segment length) is as follows:

- with 62.5/125 μm fiber multimode SIMATIC NET cable: 4 km
- with 50.0/125 μm fiber multimode SIMATIC NET cable: 5 km

Connectors

The cables are connected using BFOC sockets.

3.4.2 SCALANCE X101-1FL

Transmission speed

The transmission speed of the optical Ethernet port is 10 Mbps.

Transmission mode

The transmission mode for 10Base-FL is specified in the IEEE 802.3 standard.

Since the half duplex mode and the transmission speed cannot be modified for optical transmission, autonegotiation cannot be used.

Transmission medium

Data transmission is via multimode fiber-optic cable (FO cable). The transceiver wavelength is 820 nm.

Multimode FO cable is used with a core diameter of 50 or 62.5 μm . The light source is an LED.

The outer diameter of the FO cable is 125 μm .

Range

The maximum transmission range (segment length) is 3 km with a signal attenuation of the fiber-optic cable of ≤ 3 dB/km at 850 nm.

Connectors

The cables are connected using BFOC sockets.

3.4.3 SCALANCE X101-1LD

Transmission speed

The transmission speed of the optical Fast Ethernet port is 100 Mbps.

Transmission mode

The transmission mode for 100Base-LX is specified in the IEEE 802.3 standard.

Since the full duplex mode and the transmission speed cannot be modified for optical transmission, autonegotiation cannot be used.

Transmission medium

Data transmission is over single-mode fiber-optic cable (FO cable). The transceiver wavelength is 1310 nm.

Single-mode fiber-optic cable with a core diameter of 10 µm is used.

The outer diameter of the FO cable is 125 µm.

Sender

The light source is an "eye safe" class 1 laser with a wavelength of 1310 nm.



Range

The maximum transmission range (segment length) is 26 km with a signal attenuation of the fiber-optic cable of ≤ 0.5 dB/km.

Connectors

The cables are connected using BFOC sockets.

3.4.4 SCALANCE X101-1POF

Transmission speed

The transmission speed of the optical Fast Ethernet port is 100 Mbps.

Transmission mode

The transmission mode for 100Base-FX is specified in the IEEE 802.3 standard.

Since the full duplex mode and the transmission speed cannot be modified for optical transmission, autonegotiation cannot be used.

Transmission medium

Data is transferred via Plastic Optical Fiber cable (POF) or plastic Cladding Fiber cable (PCF).

The wavelength of POF and PCF fiber-optic cables is 650 nm.

POF fiber-optic cable with a core diameter of 980 μm is used. The light source is an LED. The outer diameter of the FO cable is 1000 μm .

PCF fiber-optic cable with a core diameter of 200 μm is used. The light source is an LED. The outer diameter of the FO cable is 230 μm .

Range

The maximum transmission range (segment length) with POF is 50 m with a signal attenuation of the fiber-optic cable of ≤ 0.23 dB/km.

The maximum transmission range (segment length) with PCF is 100 m with a signal attenuation of the fiber-optic cable of ≤ 0.01 dB/km.

Connectors

The cables are connected using SC-RJ sockets.

GI-PCF

For segment lengths longer than 100 m, you can use GI-PCF cables. Note the information of the manufacturer.

3.5 AUI port (Attachment Unit Interface)

Transmission speed

The data transmission speed is 10 Mbps.

Transmission mode

The AUI transmission mode is specified in the IEEE 802.3 standard.

Since the half duplex mode and transmission speed of 10 Mbps is specified here, autonegotiation cannot be used on the TP ports.

Transmission medium

Data is transferred via AUI cable (drop cable / EFB Ethernet transceiver cable).

Range

The maximum transmission range (segment length) is 50 m.

Medium Attachment Unit - power supply

At 12 volts, a medium attachment unit has a maximum of 500 mA available.

Connectors

The connector is a lockable 15-pin D-sub socket.

Pin assignment

The following figure shows the pinout of the 15-pin D-sub female connector.

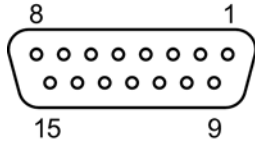

Pin number	Assignment
Shield	Ground (M-GND)
Pin 15	n. c.
Pin 14	Ground (M-GND)
Pin 13	Voltage Plus (12 V +)
Pin 12	DIN (Data In -)
Pin 11	Ground (M-GND)
Pin 10	DON (Data Out -)
Pin 9	CIN (Control In -)
Pin 8	Ground (M-GND)
Pin 7	n. c.
Pin 6	Voltage Neg (12 V -)
Pin 5	DIP (Data In +)
Pin 4	Ground (M-GND)
Pin 3	DOP (Data Out +)
Pin 2	CIP (Control In +)
Pin 1	Ground (M-GND)

3.6 LEDs

Fault LED "F" (red LED)

The fault LED indicates the incorrect functioning of the device.

LED color	LED status	Meaning
Red	Lit	The SCALANCE X-100 media converter detects a fault. At the same time, the signaling contact opens. The following faults/errors are detected: 1. Link down event on a monitored port. 2. Loss of the power supply of one of the two redundant power supplies or the power supply drops below 14 V.
-	Off	No problem has been detected by the SCALANCE X-100 media converter.

Power LED "L" (green LED)

The power LED shows the status of the power supply.

LED color	LED status	Meaning
Green	Lit	Power supply L1 or L2 is connected.
-	Off	Power supply L1 and L2 are not connected or L1 and L2 <14 V.

Note

If the green LED is not lit, no other signal LED lights up either.

Port LEDs "P" (green/yellow LEDs)

The port LEDs indicate the status of the ports.

LED color	LED status	Port LED	Meaning
Green	Lit	P1	Link exists, no data reception at port
Green	Lit	P2	Link exists, no data reception at port
Yellow	Lit	P1	Link exists, data reception at port
Yellow	Lit	P2	Link exists, data reception at port
Yellow	Flashing	P1 + P2	Setting or display of the fault mask

Note

In standalone mode, the link status of the port LEDs is only displayed if the same link status is detected at both ports P1 and P2.

In transparent link mode, the link status at the optical port (P2) is detected and displayed even without a link at the electrical port P1.

3.6 LEDs

Transparent link LED "TL" (green LED)

The transparent link LED indicates the mode of the device.

Note

Use of the SCALANCE X101-1FL or SCALANCE X101-1AUI

Direct cascading of two SCALANCE X101-1FL or SCALANCE X101-1AUI media converters is not possible and therefore also no transparent link or transparent link mode. The transparent link LED has no function.

LED color	LED status	Meaning
Green	Lit	Transparent link parameters set.
-	Off	Stand-alone mode. End devices are connected to both ports of the media converter (no cascading).

3.7 SET button

Function

With the SET button, you can display and change the set fault mask. You can also set the transparent link mode if the media converter supports cascading. For more detailed information, refer to the section "Cascade (Page 35)".

Setting the fault mask

Factory setting

When supplied (factory defaults), the fault mask is set so that the power supply L1+/M1 is monitored. No ports are monitored.

If you connect a power supply to L2+/M2, adapt the fault mask accordingly: Delete the error LED and the signaling contact or set the fault mask to the power supply L2+/M2.

Changing the setting

The changed settings remain after cycling power to the device.

Different settings are made depending on how long you hold down the SET button, as described in the following table:

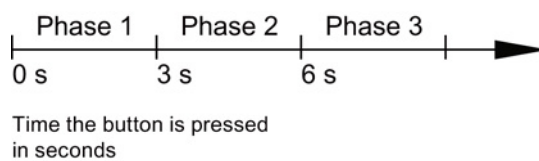

Phase	Description	
1	LEDs flash at 5 Hz	The currently set fault mask is displayed. The LEDs of the monitored ports flash. If no fault mask is set, all port LEDs flash one after the other.
	If you release the button in phase 1, this has no effect.	
2	LEDs flash at 2.5 Hz	The current status is displayed. <ul style="list-style-type: none"> The LEDs of the ports at which there is currently a link flash. The LEDs of the connected power supply flash.
	If you release the button in phase 2, this has no effect.	
3	This new status is adopted and stored as the new fault mask in phase 3.	
	LEDs flashing	If you release the SET button while the LEDs are still flashing, saving is aborted.
	LEDs lit	If you release the SET button as soon as the LEDs light up, the current settings will be stored. The stored status is displayed. <ul style="list-style-type: none"> The monitored ports are indicated by statically lit LEDs. The monitored power supply is indicated by statically lit LEDs.

3.7 SET button

Note

If an empty fault mask is set or needs to be set, the 2 port LEDs flash alternately. If the fault mask is empty, no port is monitored.

Error/fault

If the link is lost at a monitored port or a monitored power supply is lost, this is signaled as follows:

- the red fault LED lights up
- the signaling contact is opened

Setting transparent link mode

Factory setting

When shipped, the transparent link mode is disabled. The media converter is in standalone mode. A cascade is not possible.

Enabling transparent link mode

To enable the transparent link mode, press the SET button and keep it pressed for 1-2 seconds.

The transparent link LED lights up. The transparent link mode is enabled.

Disabling transparent link mode

To disable the transparent link mode, press the SET button and keep it pressed for 1-2 seconds.

The transparent link LED is off. The transparent link mode is disabled. The media converter is in standalone mode.

3.8 Cascading two media converters

If you cascade two media converters; in other words, connect them via the FO port, the transparent link mode must be enabled first using the SET button. You will find further information in the section "SET button".

Note the following restrictions:

- A maximum of two media converters can be connected in series.
- Mixed cascading of SCALANCE X-100 media converters and OMC media converters is not possible.
- Cascading is only permitted via the connection of the FO ports.
- Cascading must be set on both media converters using the SET button (transparent link LED lights up). Otherwise, there may be functional disruptions.
- The setting remains after cycling power.
- When shipped, the standalone mode is enabled; in other words no cascading.

Note

Direct cascading of two SCALANCE X101-1FL or SCALANCE X101-1AUI media converters is also not possible.

Installation

4.1 Types of installation

The devices can be installed in the following ways:

- Installation on a 35 mm DIN rail
- Installation on a SIMATIC S7-300 standard rail
- Wall mounting

WARNING

Ambient temperature between 55 °C and 60 °C

If a device is operated in an ambient temperature between 55 °C and 60 °C, the temperature of the device housing may be higher than 70 °C. The device must therefore be installed so that it is only accessible to service personnel or users that are aware of the reason for restricted access and the required safety measures at an ambient temperature of 55 °C to 60 °C.

WARNING

If the cable or conduit entry point exceeds 70 °C or the branching point of conductors exceeds 80 °C, special precautions must be taken. If the equipment is operated in an air ambient in excess of 50 °C to 60 °C, only use cables with admitted maximum operating temperature of at least 80 °C.

WARNING

Protective measures need to be taken to ensure that the rated voltage of the equipment cannot be exceeded by more than 40% by transient surges. This is achieved by operating the equipment only with SELV circuits (previously also PELV). Under no circumstances must transient surges exceed 119 V.

Note

When installing and operating the device, keep to the installation instructions and safety-related notices as described here and in the manual "SIMATIC NET Industrial Ethernet Twisted Pair and Fiber Optic Networks".

Note

Provide suitable shade to protect the device against direct sunlight. This avoids unwanted warming of the device and prevents premature aging of the device and cabling.

4.2 Installation on a DIN rail

Installation

To install the device on a 35 mm DIN rail, follow the steps below:

1. Place the second housing guide of the device on the top edge of the DIN rail.
2. Press the device down against the DIN rail until the spring catch locks in place.
3. Fit the connectors for the power supply. See also section "Power supply (Page 43)".
4. Fit the connectors for the signaling contacts. See also section "Signaling contacts (Page 45)".
5. Insert the terminal blocks into the sockets on the device.

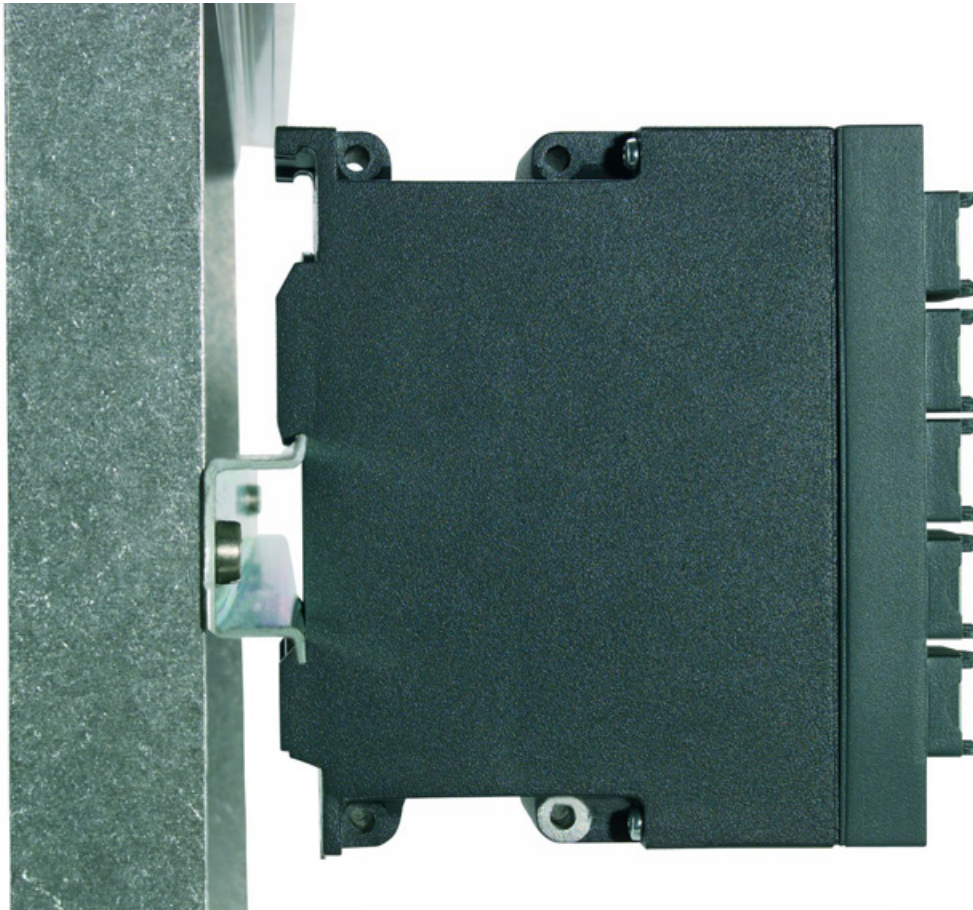

Figure 4-1 Installation on a 35 mm DIN rail

Removal

To remove the device from the DIN rail, follow the steps below:

1. Disconnect all connected cables.
2. Pull out the terminal blocks for the power supply and the signaling contact.
3. Release the DIN rail catch on the bottom of the device using a screwdriver.
4. Pull the lower part of the device away from the DIN rail.



Figure 4-2 Removal from a 35 mm DIN rail

4.3 Installation on a standard rail

Installation on a SIMATIC S7-300 standard rail

To install the device on an S7-300 standard rail, follow the steps below:

1. Place the first housing guide of the housing on the top edge of the S7-300 standard rail.
2. Screw the device to the underside of the standard rail (tightening torque 2 Nm).
3. Fit the connectors for the power supply. See also section "Power supply (Page 43)".
4. Fit the connectors for the signaling contacts. See also section "Signaling contacts (Page 45)".
5. Insert the terminal blocks into the sockets on the device.



Figure 4-3 Standard rail mounting X-100MC

Removal

To remove the device from the S7-300 standard rail, follow the steps below:

1. Disconnect all connected cables.
2. Release the screw on the bottom of the standard rail.
3. Lift the device off the standard rail.

4.4 Wall mounting

To mount the device on a wall, you require the following:

- 4 wall plugs, 6 mm in diameter and 30 mm long
- 4 screws 3.5 mm in diameter and 40 mm long

To mount the device on a wall, follow the steps below:

1. Prepare the drill holes for wall mounting. For the precise dimensions, refer to the section "Dimension drawings (Page 69)".
2. Fit the connectors for the power supply. See also section "Power supply (Page 43)".
3. Fit the connectors for the signaling contacts. See also section "Signaling contacts (Page 45)".
4. Insert the terminal blocks into the sockets on the device.
5. Screw the device to the wall.

Note

The wall mounting must be capable of supporting at least four times the weight of the device.

Connecting up

5.1 Power supply

The power supply is connected using a 4-terminal plug-in block. The power supply can be connected redundantly. Both inputs are isolated. There is no distribution of load. When a redundant power supply is used, the power supply unit with the higher output voltage supplies the SCALANCE X-100 media converter alone. The power supply is connected over a high resistance with the enclosure to allow an ungrounded setup.

The following figure shows the position of the power supply of the SCALANCE X-100 media converters and the assignment of the terminal block.

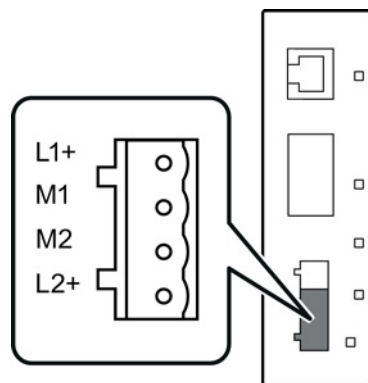

Pin number	Assignment
Pin 1	L1+ (24 VDC)
Pin 2	M1 (ground)
Pin 3	M2 (ground)
Pin 4	L2+ (24 VDC)

⚠ WARNING

Incorrect power supply

The power supply unit to supply the device must comply with NEC Class 2 (voltage range 18 - 32 V, current requirement 350 mA).

Do not operate the device with an AC voltage.

Never operate the device with DC voltages higher than 32 VDC.

 **WARNING**

The equipment is designed for operation with Safety Extra-Low Voltage (SELV) by a Limited Power Source (LPS).

This means that only SELV / LPS complying with IEC 60950-1 / EN 60950-1 / VDE 0805-1 must be connected to the power supply terminals. The power supply unit for the equipment power supply must comply with NEC Class 2, as described by the National Electrical Code (r) (ANSI / NFPA 70).

If the equipment is connected to a redundant power supply (two separate power supplies), both must meet these requirements.

5.2 Signaling contact

The signaling contact is connected to a 2-pin plug-in terminal block. The signaling contact (optical relay contact) is a floating switch with which error/fault states can be signaled by breaking the contact.

NOTICE

Damage due to voltage being too high

The signaling contact can be subjected to a maximum load of 100 mA (safety extra-low voltage SELV, 24 VDC).

Higher voltages or currents can damage the device!

The following figure shows the position of the signaling contacts of the SCALANCE X-100 media converters and the assignment of the terminal block.

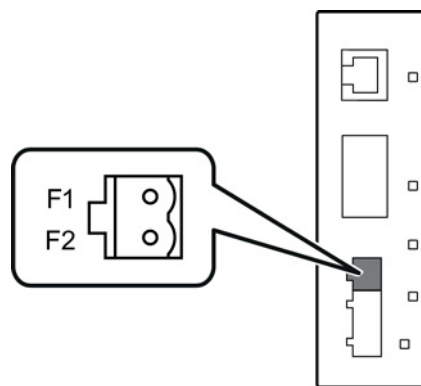

Pin number	Assignment
Pin 1	F1
Pin 2	F2

The following errors/faults can be signaled by the signaling contact:

- The failure of a link on one of the two monitored ports.
- The failure of one of the two redundant power supplies.

The connection or disconnection of a communication node on an unmonitored port does not lead to an error message.

The signaling contact remains activated until the error/fault is eliminated or until the current status is applied as the new desired status using the SET button.

When the device is turned off, the signaling contact is always activated (open).

5.3 Grounding

Installation on a DIN rail

The device is grounded over the DIN rail.

S7 standard rail

The device is grounded over its rear panel and the neck of the screw.

Wall mounting

The device is grounded by the securing screw in the unpainted hole.

Note that the device must be grounded over a securing screw with as low a low resistance as possible.

If the device is mounted on a non-conductive base, a grounding cable must be fitted. The grounding cable is not supplied with the device. Connect the paint-free surface of the device to the nearest grounding point using the grounding cable.

5.4 IE FC RJ-45 Plug 180

The rugged node connectors are designed for industry with PROFINET-compliant connectors and provide additional strain and bending relief with a locking mechanism on the casing.

Fitting the IE FC RJ45 Plug 180 to the IE FC Standard Cable

You will find the notes on installation in the instructions that ship with the IE FC RJ45 Plug 180.

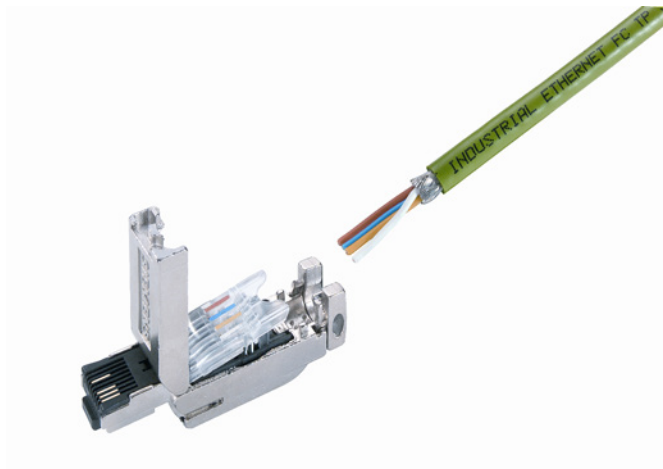

Figure 5-1 IE FC 45 Plug 180

Plugging in the IE FC RJ45 Plug 180

Plug the IE FC RJ45 Plug 180 into the twisted-pair port of the device until it locks in place.



Figure 5-2 Plugging in the IE FC RJ45 Plug 180

With its tight fit and locking mechanism with the PROFINET-compliant male connector IE FC RJ45 Plug 180, the securing collar on the TP port of the device ensures a rugged node attachment that provides strain and bending relief for the RJ-45 jack.

Pulling the IE FC RJ45 Plug 180

Press on the locking lever of the IE FC RJ45 Plug 180 gently to remove the plug.

If there is not enough space to release the lock with your hand, you can also use a 2.5 mm screwdriver. You can then remove the IE FC RJ45 Plug 180 from the RJ-45 jack.

5.5 AUI cable

Connecting and removing the AUI cable (drop cable)

The 15-pin D-sub female connector has a locking mechanism. To release the connector, the locking mechanism is pressed down and to close it, it is pressed up.



Figure 5-3 Locking mechanism in the open position



Figure 5-4 Locking or unlocking the D-sub connector

Maintenance

Fuses

The media converters of the SCALANCE°X-100 product line have a resettable fuse / PTC. If the fuse triggers (all LEDs are off despite correctly applied power supply), the device should be disconnected from the power supply for approximately 30 minutes before turning it on again.

Device defective

If any other fault develops, please send the device to your SIEMENS service center for repair. Repairs on-site are not possible.

Technical specifications

7.1 SCALANCE X101-1

Table 7- 1 Technical specifications of the SCALANCE X101-1

Technical specifications	
Order number	
SCALANCE X101-1	6GK5101-1BB00-2AA3
Attachment to Industrial Ethernet	
Quantity	1
Design	RJ-45 jack with MDI-X pinning
Properties	Full duplex
Transmission speed	100 Mbps
Optical connectors	
Quantity	1
Design	BFOC socket
Properties	Full duplex to 100 Base-FX
Transmission speed	100 Mbps
Permitted cable lengths (Industrial Ethernet)	Alternative combinations per length range
0 ... 85 m	<ul style="list-style-type: none"> • Max. 85 m IE FC TP Marine/Trailing Cable with IE FC RJ45 Plug 180 • Max. 75 m IE FC TP Marine/Trailing Cable + 10 m TP Cord via IE FC RJ45 Outlet
0 ... 100 m	<ul style="list-style-type: none"> • Max. 100 m IE FC TP Standard Cable with IE FC RJ45 Plug 180 • Max. 90 m IE FC TP Standard Cable + 10 m TP Cord via IE FC RJ45 Outlet

Technical specifications

7.1 SCALANCE X101-1

Technical specifications

Optical parameters

Cable type	Multimode glass FO cable, cable cross sections 62.5/125 μm and 50/125 μm	
Permitted cable length (glass FO cable)	Cable cross-section	Permitted cable length
	<ul style="list-style-type: none"> • 62.5/125 μm • 50/125 μm 	<ul style="list-style-type: none"> • 0 to 4000 m • 0 to 5000 m
Attenuation	≤ 1 dB/km at 1300 nm 1200 MHz x km at 1300 nm 6 dB max. permitted FO cable attenuation with 3 dB link power margin	
Bending radius	once without tensile force	100 mm
	several times with tensile force	150 mm

Electrical data

Power supply	Voltage range	18 to 32 VDC Safe Extra Low Voltage (SELV)
	Rated voltage	24 VDC
	Design	4-terminal plug-in block
Signaling contact	Design	2-terminal plug-in block
Current consumption	Typical	120 mA
Minimum rated current of the power supply unit		170 mA
Power loss at 24 VDC	Typical	3 W
Overvoltage protection at input		PTC resettable fuse (0.5 A / 60 V)

Permitted ambient conditions

Ambient temperature	During operation	-10 °C to +60 °C
	During storage	-40 °C to +80 °C
	During transportation	-40 °C to +80 °C
Relative humidity	During operation	≤ 95 % no condensation
Operating altitude	During operation	$\leq 2,000$ m above sea level at max. 56 °C ambient temperature
		$\leq 3,000$ m above sea level at max. 50 °C ambient temperature

Design, dimensions and weight

Immunity	EN 61000-6-2	
Emission	EN 61000-6-3	
Degree of protection	IP30	
MTBF (EN/IEC 61709, 40 °C)	152 years	
Housing material	Basic housing	Die cast aluminum, powder coated
	Front cover	Polyphenylene ether + polystyrene (PPE+PS plastic)

Technical specifications

Weight	550 g
Dimensions (W x H x D)	40 x 125 x 124 mm
Installation options	<ul style="list-style-type: none">• Mounting on a DIN rail• Mounting on an S7-300 standard rail• Wall mounting

Switching properties

Response to LLDP frames	Forwarding
Response to spanning tree BPDU frames	Forwarding

Note

The number of SCALANCE X Industrial Ethernet devices connected in a line influences the frame delay time.

When a frame runs through the SCALANCE X-100 media converter, this is delayed typically by approximately 8 μ s by the cut through function of the internal switch.

At 100% bus load, these times can be higher depending on the system (maximum 140 μ s).

Note**Temperature code for c-UL-us for hazardous locations, FM and ATEX Zone 2**

You will find the temperature code "T.." or the maximum ambient temperature "Ta: .." on the type plate.

7.2 SCALANCE X101-1FL

Table 7- 2 Technical specifications of the SCALANCE X101-1FL

Technical specifications		
Order number		
SCALANCE X101-1FL	6GK5101-1BY00-2AA3	
Attachment to Industrial Ethernet		
Quantity	1	
Design	RJ-45 jack with MDI-X pinning	
Properties	Half duplex	
Transmission speed	10 Mbps	
Optical connectors		
Quantity	1	
Design	BFOC socket	
Properties	Half duplex to 10 Base-FL	
Transmission speed	10 Mbps	
Permitted cable lengths (Industrial Ethernet)	Alternative combinations per length range	
0 ... 85 m	<ul style="list-style-type: none"> Max. 85 m IE FC TP Marine/Trailing Cable with IE FC RJ45 Plug 180 Max. 75 m IE FC TP Marine/Trailing Cable + 10 m TP Cord via IE FC RJ45 Outlet 	
0 ... 100 m	<ul style="list-style-type: none"> Max. 100 m IE FC TP Standard Cable with IE FC RJ45 Plug 180 Max. 90 m IE FC TP Standard Cable + 10 m TP Cord via IE FC RJ45 Outlet 	
Optical parameters		
Cable type	Multimode glass FO cable, cable cross sections 62.5/125 µm and 50/125 µm	
Permitted cable length (glass FO cable)	Cable cross-section	Permitted cable length
	<ul style="list-style-type: none"> 62.5/125 µm 50/125 µm 	<ul style="list-style-type: none"> 0 to 3000 m 0 to 3000 m
Attenuation	≤ 3 dB/km at 850 nm 600 MHz x km at 850 nm 12 dB max. permitted FO cable attenuation with 3 dB link power margin	
Bending radius	once without tensile force	100 mm
	several times with tensile force	150 mm

Technical specifications		
Electrical data		
Power supply	Voltage range	18 to 32 VDC Safe Extra Low Voltage (SELV)
	Rated voltage	24 VDC
	Design	4-terminal plug-in block
Signaling contact	Design	2-terminal plug-in block
Current consumption	Typical	120 mA
Minimum rated current of the power supply unit		200 mA
Power loss at 24 VDC	Typical	3 W
Overvoltage protection at input		PTC resettable fuse (0.5 A / 60 V)
Permitted ambient conditions		
Ambient temperature	During operation	-10 °C to +60 °C
	During storage	-40 °C to +80 °C
	During transportation	-40 °C to +80 °C
Relative humidity	During operation	≤ 95 % no condensation
Operating altitude	During operation	≤ 2,000 m above sea level at max. 56 °C ambient temperature
		≤ 3,000 m above sea level at max. 50 °C ambient temperature
Design, dimensions and weight		
Immunity	EN 61000-6-2	
Emission	EN 61000-6-3	
Degree of protection	IP30	
MTBF (EN/IEC 61709, 40 °C)	134 years	
Housing material	Basic housing	Die cast aluminum, powder coated
	Front cover	Polyphenylene ether + polystyrene (PPE+PS plastic)
Weight	550 g	
Dimensions (W x H x D)	40 x 125 x 124 mm	
Installation options	<ul style="list-style-type: none"> • Mounting on a DIN rail • Mounting on an S7-300 standard rail • Wall mounting 	

Technical specifications

Switching properties

Response to LLDP frames	Forwarding
-------------------------	------------

Response to spanning tree BPDU frames	Forwarding
---------------------------------------	------------

Note

The number of SCALANCE X Industrial Ethernet devices connected in a line influences the frame delay time.

When a frame runs through the SCALANCE X-100 media converter, this is delayed typically by approximately 40 µs by the cut through function of the internal switch.

At 100% bus load, these times can be higher depending on the system (maximum 180 µs).

Note

Temperature code for c-UL-us for hazardous locations, FM and ATEX Zone 2

You will find the temperature code "T.." or the maximum ambient temperature "Ta: .." on the type plate.

7.3 SCALANCE X101-1LD

Table 7- 3 Technical specifications of the SCALANCE X101-1LD

Technical specifications		
Order number		
SCALANCE X101-1LD	6GK5101-1BC00-2AA3	
Attachment to Industrial Ethernet		
Quantity	1	
Design	RJ-45 jack with MDI-X pinning	
Properties	Full duplex	
Transmission speed	100 Mbps	
Optical connectors		
Quantity	1	
Design	BFOC socket	
Properties	Full duplex to 100 Base-LX	
Transmission speed	100 Mbps	
Permitted cable lengths (Industrial Ethernet)	Alternative combinations per length range	
0 ... 85 m	<ul style="list-style-type: none"> • Max. 85 m IE FC TP Marine/Trailing Cable with IE FC RJ45 Plug 180 • Max. 75 m IE FC TP Marine/Trailing Cable + 10 m TP Cord via IE FC RJ45 Outlet 	
0 ... 100 m	<ul style="list-style-type: none"> • Max. 100 m IE FC TP Standard Cable with IE FC RJ45 Plug 180 • Max. 90 m IE FC TP Standard Cable + 10 m TP Cord via IE FC RJ45 Outlet 	
Optical parameters		
Cable type	Single mode glass FO cable	
Cable cross-section	10/125 µm	
Permitted cable length	0 to 26,000 m	
Attenuation	≤ 0.5 dB/km at 1310 nm 13 dB max. permitted FO cable attenuation with 2 dB link power margin	
Bending radius	once without tensile force	100 mm
	several times with tensile force	150 mm

Technical specifications

7.3 SCALANCE X101-1LD

Technical specifications		
Electrical data		
Power supply	Voltage range	18 to 32 VDC Safe Extra Low Voltage (SELV)
	Rated voltage	24 VDC
	Design	4-terminal plug-in block
Signaling contact	Design	2-terminal plug-in block
Current consumption	Typical	120 mA
Minimum rated current of the power supply unit		200 mA
Power loss at 24 VDC	Typical	3 W
Overvoltage protection at input		PTC resettable fuse (0.5 A / 60 V)
Permitted ambient conditions		
Ambient temperature	During operation	-10 °C to +60 °C
	During storage	-40 °C to +80 °C
	During transportation	-40 °C to +80 °C
Relative humidity	During operation	≤ 95 % no condensation
Operating altitude	During operation	≤ 2,000 m above sea level at max. 56 °C ambient temperature
		≤ 3,000 m above sea level at max. 50 °C ambient temperature
Design, dimensions and weight		
Immunity	EN 61000-6-2 Class A	
Emission	EN 61000-6-3	
Degree of protection	IP30	
MTBF (EN/IEC 61709, 40 °C)	134 years	
Housing material	Basic housing	Die cast aluminum, powder coated
	Front cover	Polyphenylene ether + polystyrene (PPE+PS plastic)
Weight	550 g	
Dimensions (W x H x D)	40 x 125 x 124 mm	
Installation options	<ul style="list-style-type: none">• Mounting on a DIN rail• Mounting on an S7-300 standard rail• Wall mounting	

Technical specifications

Switching properties

Response to LLDP frames	Forwarding
Response to spanning tree BPDU frames	Forwarding

Note

The number of SCALANCE X Industrial Ethernet devices connected in a line influences the frame delay time.

When a frame runs through the SCALANCE X-100 media converter, this is delayed typically by approximately 8 μ s by the cut through function of the internal switch.

At 100% bus load, these times can be higher depending on the system (maximum 140 μ s).

Note

Temperature code for c-UL-us for hazardous locations, FM and ATEX Zone 2

You will find the temperature code "T.." or the maximum ambient temperature "Ta: .." on the type plate.

7.4 SCALANCE X101-1POF

Table 7- 4 Technical specifications of the SCALANCE X101-1POF

Technical specifications		
Order number		
SCALANCE X101-1POF	6GK5101-1BH00-2AA3	
Attachment to Industrial Ethernet		
Quantity	1	
Design	RJ-45 jack with MDI-X pinning	
Properties	Full duplex	
Transmission speed	100 Mbps	
Optical connectors		
Quantity	1	
Design	SC-RJ jack	
Properties	Full duplex to 100 Base-FX	
Transmission speed	100 Mbps	
Permitted cable lengths (Industrial Ethernet)	Alternative combinations per length range	
0 ... 85 m	<ul style="list-style-type: none"> • Max. 85 m IE FC TP Marine/Trailing Cable with IE FC RJ45 Plug 180 • Max. 75 m IE FC TP Marine/Trailing Cable + 10 m TP Cord via IE FC RJ45 Outlet 	
0 ... 100 m	<ul style="list-style-type: none"> • Max. 100 m IE FC TP Standard Cable with IE FC RJ45 Plug 180 • Max. 90 m IE FC TP Standard Cable + 10 m TP Cord via IE FC RJ45 Outlet 	
Optical parameters		
Cable type	Plastic Optical Fiber cable	
Cable cross-section	980/1000 µm POF	
Permitted cable length	0 to 50 m	
Attenuation	≤ 0.23 dB/m at 660 nm; 11.5 dB max. permitted FO cable attenuation with 3 dB link power margin	
Bending radius	once without tensile force	100 mm
	several times with tensile force	150 mm

Technical specifications		
Electrical data		
Power supply	Voltage range	18 to 32 VDC Safe Extra Low Voltage (SELV)
	Rated voltage	24 VDC
	Design	4-terminal plug-in block
Signaling contact	Design	2-terminal plug-in block
Current consumption	Typical	120 mA
Minimum rated current of the power supply unit		200 mA
Power loss at 24 VDC	Typical	3 W
Overvoltage protection at input		PTC resettable fuse (0.5 A / 60 V)
Permitted ambient conditions		
Ambient temperature	During operation	-10 °C to +60 °C
	During storage	-40 °C to +80 °C
	During transportation	-40 °C to +80 °C
Relative humidity	During operation	≤ 95 % no condensation
Operating altitude	During operation	≤ 2,000 m above sea level at max. 56 °C ambient temperature
		≤ 3,000 m above sea level at max. 50 °C ambient temperature
Design, dimensions and weight		
Immunity	EN 61000-6-2	
Emission	EN 61000-6-3	
Degree of protection	IP30	
MTBF (EN/IEC 61709, 40 °C)	134 years	
Housing material	Basic housing	Die cast aluminum, powder coated
	Front cover	Polyphenylene ether + polystyrene (PPE+PS plastic)
Weight	550 g	
Dimensions (W x H x D)	40 x 125 x 124 mm	
Installation options	<ul style="list-style-type: none"> • Mounting on a DIN rail • Mounting on an S7-300 standard rail • Wall mounting 	
Switching properties		
Response to LLDP frames	Forwarding	
Response to spanning tree BPDU frames	Forwarding	

Note

The number of SCALANCE X Industrial Ethernet devices connected in a line influences the frame delay time.

When a frame runs through the SCALANCE X-100 media converter, this is delayed typically by approximately 8 μ s by the cut through function of the internal switch.

At 100% bus load, these times can be higher depending on the system (maximum 140 μ s).

Note

Temperature code for c-UL-us for hazardous locations, FM and ATEX Zone 2

You will find the temperature code "T.." or the maximum ambient temperature "Ta: .." on the type plate.

7.5 SCALANCE X101-1AUI

Table 7- 5 Technical specifications of the SCALANCE X101-1POF

Technical specifications		
Order number		
SCALANCE X101-1AUI	6GK5101-1BX00-2AA3	
Attachment to Industrial Ethernet		
Quantity	1	
Design	RJ-45 jack with MDI-X pinning	
Properties	Half duplex to BaseT	
Transmission speed	10 Mbps	
Quantity	1	
Design	15-pin D-sub female connector	
Properties	Half duplex	
Transmission speed	10 Mbps	
Permitted cable lengths (Industrial Ethernet)	Alternative combinations per length range	
0 ... 85 m	<ul style="list-style-type: none"> • Max. 85 m IE FC TP Marine/Trailing Cable with IE FC RJ45 Plug 180 • Max. 75 m IE FC TP Marine/Trailing Cable + 10 m TP Cord via IE FC RJ45 Outlet 	
0 ... 100 m	<ul style="list-style-type: none"> • Max. 100 m IE FC TP Standard Cable with IE FC RJ45 Plug 180 • Max. 90 m IE FC TP Standard Cable + 10 m TP Cord via IE FC RJ45 Outlet 	
Permitted cable lengths (AUI cable length)	Alternative combinations per length range	
0 to 50 m	AUI cable (Drop Cable)	
Electrical data		
Power supply	Voltage range	18 to 32 VDC Safe Extra Low Voltage (SELV)
	Rated voltage	24 VDC
	Design	4-terminal plug-in block
Signaling contact	Design	2-terminal plug-in block
Current consumption	Typical	
	<ul style="list-style-type: none"> • at 2.1 W at the 12 V AUI output • at 6.0 W at the 12 V AUI output 	<ul style="list-style-type: none"> • 160 mA • 350 mA
	Power loss at 24 VDC	Typical

Technical specifications		
Overvoltage protection at input		PTC resettable fuse (1.0 A)
Maximum permitted power consumption of the consumer at the 12 V AUI output (MAU)		6 W (500 mA / 12 V)
Permitted ambient conditions		
Ambient temperature	During operation	-10 °C to +60 °C
	During storage	-40 °C to +80 °C
	During transportation	-40 °C to +80 °C
Relative humidity	During operation	≤ 95 % no condensation
Operating altitude	During operation	≤ 2,000 m above sea level at max. 56 °C ambient temperature
		≤ 3,000 m above sea level at max. 50 °C ambient temperature
Design, dimensions and weight		
Immunity	EN 61000-6-2	
Emission	EN 61000-6-3	
Degree of protection	IP30	
MTBF (EN/IEC 61709, 40 °C)	136 years	
Housing material	Basic housing	Die cast aluminum, powder coated
	Front cover	Polyphenylene ether + polystyrene (PPE+PS plastic)
Weight	560 g	
Dimensions (W x H x D)	40 x 125 x 124 mm	
Installation options	<ul style="list-style-type: none"> • Mounting on a DIN rail • Mounting on an S7-300 standard rail • Wall mounting 	
Switching properties		
Response to LLDP frames	Forwarding	
Response to spanning tree BPDU frames	Forwarding	

Note

The number of SCALANCE X Industrial Ethernet devices connected in a line influences the frame delay time.

When a frame runs through the SCALANCE X-100 media converter, this is delayed typically by approximately 40 µs by the cut through function of the internal switch.

At 100% bus load, these times can be higher depending on the system (maximum 180 µs).

Note

Temperature code for c-UL-us for hazardous locations, FM and ATEX Zone 2

You will find the temperature code "T.." or the maximum ambient temperature "Ta: .." on the type plate.

Approvals

The SIMATIC NET products described in these Operating Instructions have the approvals listed below.

Note

Issued approvals on the type plate of the device

The specified approvals apply only when the corresponding mark is printed on the product. You can check which of the following approvals have been granted for your product by the markings on the type plate.

EMC directive

The devices meet the requirements of the EC Directive 2004/108/EC "Electromagnetic Compatibility".

Area of application

The devices are designed for installation in an industrial environment:

Area of application	Requirements for	
	Emission	Immunity
Industrial area	EN 61000-6-4 : 2007 + A1 : 2011	EN 61000-6-2 : 2005 + AC : 2005

Installation Guidelines

The devices meet the requirements if you keep to the installation instructions and safety-related notices as described here and in the manual "SIMATIC NET Industrial Ethernet Twisted Pair and Fiber Optic Networks (<http://support.automation.siemens.com/WW/view/en/8763736>)" when installing and operating the device.

Declaration of Conformity

The EC Declaration of Conformity is available for the responsible authorities according to the above-mentioned EC Directive at the following address:

Siemens Aktiengesellschaft
Postfach 4848
D-90026 Nürnberg, Germany

Notes for the Manufacturers of Machines

The devices are not machines in the sense of the EC Machinery Directive. There is therefore no declaration of conformity relating to the EC Machinery Directive 2006/42/EC for these devices.

If the devices are part of the equipment of a machine, they must be included in the declaration of conformity procedure by the manufacturer of the machine.

ATEX (explosion protection directive)

WARNING

When using SIMATIC NET products in hazardous area zone 2, make absolutely sure that the associated conditions in the following document are adhered to:

"SIMATIC NET Product Information Use of subassemblies/modules in a Zone 2 Hazardous Area".

You will find this document

- on the data medium that ships with some devices.
- on the Internet pages of Siemens Industry Online Support (<http://support.automation.siemens.com/WW/view/en>).

Enter the document identification number C234 as the search term.

SIMATIC NET products meet the requirements of the EC directive:94/9/EC "Equipment and Protective Devices for Use in Potentially Explosive Atmospheres".

ATEX classification:

II 3 G Ex nA IIC T4 Gc

KEMA 07ATEX0145 X

The products meet the requirements of the following standards:

- EN 60079-15: 2010 (electrical apparatus for potentially explosive atmospheres; Type of protection "n")
- EN 60079-0: 2009 (Explosive atmospheres - Part 0: Equipment - General requirements)

IECEX

The SIMATIC NET products meet the requirements of explosion protection according to IECEX.

IECEX classification:

Ex nA IIC T4 Gc

DEK 14.0025X

The products meet the requirements of the following standards:

- IEC 60079-15 : 2010 (Explosive atmospheres - Part 15: Equipment protection by type of protection "n")
- IEC 60079-0 : 2011 (Explosive atmospheres - Part 0: Equipment - General requirements)

FM

The product meets the requirements of the standards:

- Factory Mutual Approval Standard Class Number 3611
- FM Hazardous (Classified) Location Electrical Equipment:
Non Incendive / Class I / Division 2 / Groups A,B,C,D / T4 and
Non Incendive / Class I / Zone 2 / Group IIC / T4

C-Tick

The product meets the requirements of the AS/NZS 2064 standard (Class A).

cULus for Hazardous Locations

ANSI/ISA 12.12.01-2007, CSA C22.2 No. 213-M1987

CL. 1, Div. 2 GP. A.B.C.D T..

CL. 1, Zone 2, GP, IIC, T..

CL. 1, Zone 2, AEx nC IIC T..

(T.. = For detailed information on the temperature class, refer to the type plate)

cULus Approval for Information Technology Equipment

cULus Listed I. T. E.

Underwriters Laboratories Inc. complying with

- UL 60950-1 (Information Technology Equipment)
- CSA C22.2 No. 60950-1-03

Report no. E115352

Mechanical stability (in operation)

Device	DIN EN 60068-2-6 oscillation	DIN EN 60068-2-29 permanent shock
	10 - 58 Hz: 0.075 mm	100 m/s ² , 16 ms duration
	58 - 500 Hz: 10 m/s ²	100 shocks per axis
	10 cycles	
X101-1	•	•
X101-1FL	•	•
X101-1LD	•	•
X101-1POF	•	•

Device	DIN EN 60068-2-6 oscillation	DIN EN 60068-2-27 shock
	5 - 8.51 Hz: 3.5 mm	150 m/s ² , 11 ms duration
	8.51 - 150 Hz: 5 m/s ²	6 shocks per axis
	1 oct/min, 10 cycles	
X101-1AUI	•	•

Dimension drawings

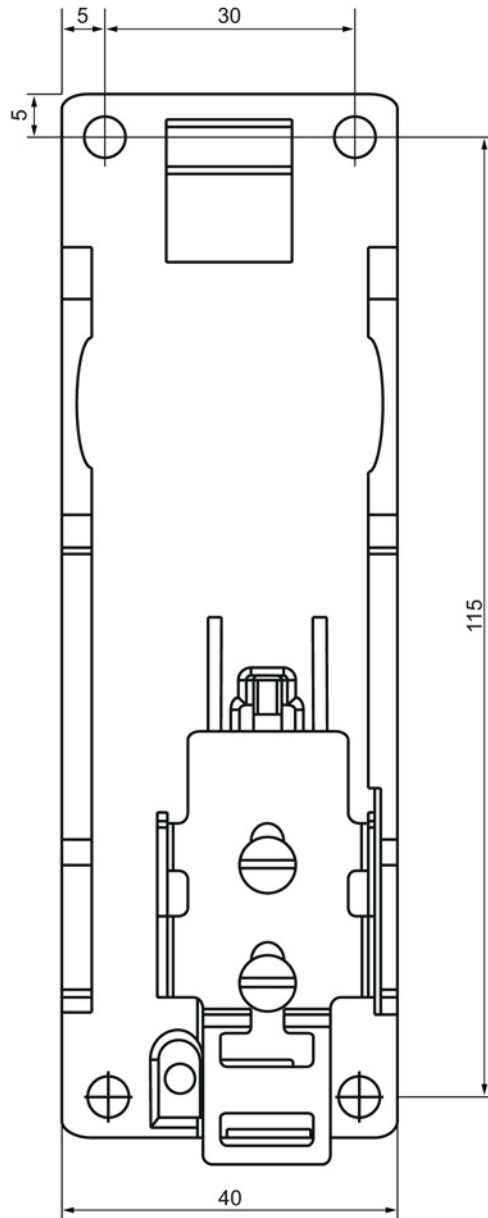

Figure 9-1 Dimension drawing, rear view

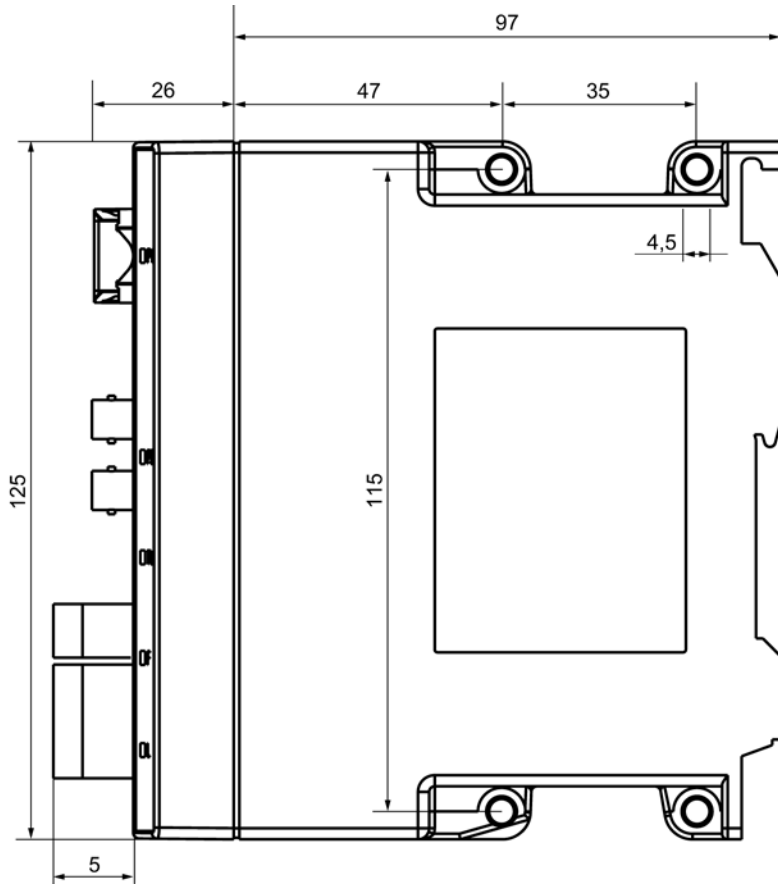

Figure 9-2 Dimension drawing, side view

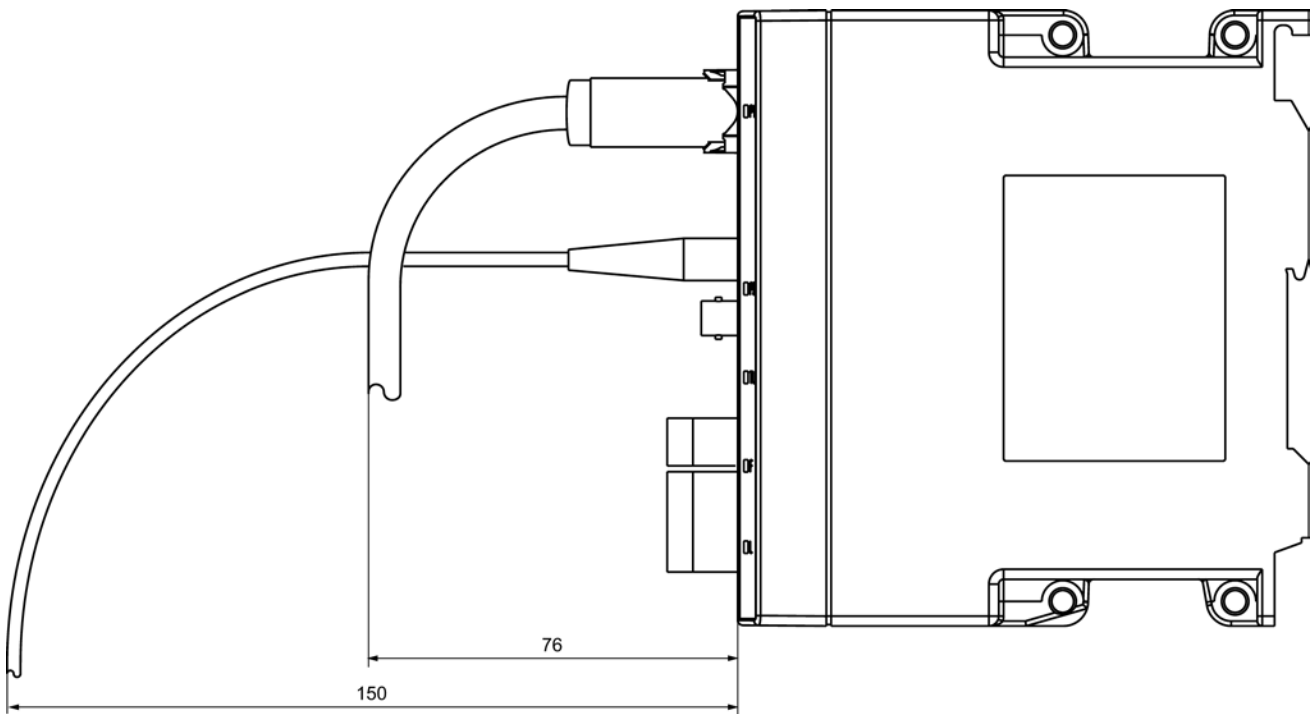

Figure 9-3 Dimension drawing, bending radii

Index

A

- Accessories, 8
- Approvals, 65
- Attachment to Industrial Ethernet, 51, 54, 57, 60, 63
- AUI port, 29
- Auto polarity exchange, 24
- Autonegotiation, 24

B

- Bus topology, 11

C

- Cable type, 17
- Cascade, 35
- CE mark, 65
- Connecting in series, 35
- Connectors
 - SCALANCE X101-1, 25
 - SCALANCE X101-1FL, 26
 - SCALANCE X101-1LD, 27
 - SCALANCE X101-1POF, 28
- Coupling of network segments, 14

D

- Declaration of Conformity, 65
- Design, dimensions and weight, 52, 55, 58, 61, 64
- Dimension drawing, 69
 - Bending radii, 71
 - Rear view, 69
 - Side view, 70

E

- Electrical data, 52, 55, 58, 61, 63

F

- Fault mask
 - Changing the setting, 33
 - Error/fault, 34

- Factory setting, 33
- FO port, 25
 - SCALANCE X101-1, 25
 - SCALANCE X101-1FL, 26
 - SCALANCE X101-1LD, 27
 - SCALANCE X101-1POF, 28
- Further documentation, 5

G

- GI-PCF, 28
- Glossary, 6
- Grounding, 46
 - Installation on a DIN rail, 46
 - S7 standard rail, 46
 - Wall mounting, 46

I

- IE FC RJ-45 Plug 180, 46
 - Installation, 46
 - Plugging in, 47
 - Pulling, 47
- Installation
 - Installation on a DIN rail, 38
 - Installation on a standard rail, 40
 - Types of installation, 37
 - Wall mounting, 41

L

- LEDs, 31
 - Fault LED (red LED), 31
 - Port LEDs (green/yellow LEDs), 31
 - Power LED (green LED), 31
 - Transparent link LED (green LED), 32

M

- Maintenance, 49
- MDI / MDI-X autocrossover function, 24

N

- Network topologies, 11
 - Coupling of network segments, 14

Network topology
 Bus topology, 11
 Ring topology, 13
 Star topology, 12

O

Optical connectors, 51, 54, 57, 60
Optical parameters, 52, 54, 57, 60
Order numbers, 5, 51, 54, 57, 60, 63

P

Permitted ambient conditions, 52, 55, 58, 61, 64
Permitted cable lengths, 23, 51, 54, 57, 60, 63
Pin assignment, 23
Possible attachments
 SCALANCE X101-1, 18
 SCALANCE X101-1FL, 19
 SCALANCE X101-1LD, 20
 SCALANCE X101-1POF, 21
Power supply, 43
Product characteristics, 17

R

Range
 SCALANCE X101-1, 25
 SCALANCE X101-1LD, 27
 SCALANCE X101-1POF, 28
Ring topology, 13
 Electrical ring, 13
RJ-45, 23

S

SCALANCE X101-1
 Attachment to Industrial Ethernet, 51
 Design, dimensions and weight, 52
 Electrical data, 52
 Frame delay time, 53
 Optical connectors, 51
 Optical parameters, 52
 Order numbers, 51
 Permitted ambient conditions, 52
 Permitted cable lengths, 51
 Switching properties, 53
 Transmission speed, 25
SCALANCE X101-1AUI
 Attachment to Industrial Ethernet, 63

 Design, dimensions and weight, 64
 Electrical data, 63
 Frame delay time, 64
 Order numbers, 63
 Permitted ambient conditions, 64
 Permitted cable lengths, 63
 Switching properties, 64
SCALANCE X101-1FL
 Attachment to Industrial Ethernet, 54
 Design, dimensions and weight, 55
 Electrical data, 55
 Frame delay time, 56
 Optical connectors, 54
 Optical parameters, 54
 Order numbers, 54
 Permitted ambient conditions, 55
 Permitted cable lengths, 54
 Switching properties, 56
SCALANCE X101-1LD
 Attachment to Industrial Ethernet, 57
 Design, dimensions and weight, 58
 Electrical data, 58
 Frame delay time, 59
 Optical connectors, 57
 Optical parameters, 57
 Order numbers, 57
 Permitted ambient conditions, 58
 Permitted cable lengths, 57
 Switching properties, 59
SCALANCE X101-1POF
 Attachment to Industrial Ethernet, 60
 Design, dimensions and weight, 61
 Electrical data, 61
 Frame delay time, 62
 Optical connectors, 60
 Optical parameters, 60
 Order numbers, 60
 Permitted ambient conditions, 61
 Permitted cable lengths, 60
 Switching properties, 61
Scope of delivery, 8
Sender, 27
 SCALANCE X101-1LD, 27
SET button, 33
 Function, 33
Signaling contact, 45
SIMATIC NET glossary, 6
Star topology, 12
Switching properties, 53, 56, 59, 61, 64

T

- Technical specifications, 51
 - SCALANCE X101-1, 51
 - SCALANCE X101-1AUI, 63
 - SCALANCE X101-1FL, 54
 - SCALANCE X101-1LD, 57
 - SCALANCE X101-1POF, 60
- TP ports, 23
- Transceiver wavelength, 17
- Transmission medium
 - SCALANCE X101-1, 25
 - SCALANCE X101-1FL, 26
 - SCALANCE X101-1LD, 27
 - SCALANCE X101-1POF, 28
- Transmission mode
 - SCALANCE X101-1, 25
 - SCALANCE X101-1FL, 26
 - SCALANCE X101-1LD, 27
 - SCALANCE X101-1POF, 28
- Transmission speed
 - SCALANCE X101-1FL, 26
 - SCALANCE X101-1LD, 27
 - SCALANCE X101-1POF, 28
- Transparent link mode
 - disabling, 34
 - enabling, 34
 - Factory setting, 34

