

# SIEMENS

## SIMATIC NET

### Industrial Ethernet Switches SCALANCE X-200



#### Operating Instructions

<u>Preface</u>	
<u>Functions</u>	<b>1</b>
<u>Description of the device</u>	<b>2</b>
<u>Safety notices</u>	<b>3</b>
<u>Installation</u>	<b>4</b>
<u>Connecting up</u>	<b>5</b>
<u>Approvals</u>	<b>6</b>
<u>Technical specifications</u>	<b>7</b>
<u>Dimension drawings</u>	<b>A</b>
<u>Test of mechanical stability</u>	<b>B</b>
<u>Training, Service &amp; Support</u>	<b>C</b>

## Legal information

### Warning notice system

This manual contains notices you have to observe in order to ensure your personal safety, as well as to prevent damage to property. The notices referring to your personal safety are highlighted in the manual by a safety alert symbol, notices referring only to property damage have no safety alert symbol. These notices shown below are graded according to the degree of danger.

 <b>DANGER</b>
indicates that death or severe personal injury <b>will</b> result if proper precautions are not taken.
 <b>WARNING</b>
indicates that death or severe personal injury <b>may</b> result if proper precautions are not taken.
 <b>CAUTION</b>
indicates that minor personal injury can result if proper precautions are not taken.
<b>NOTICE</b>
indicates that property damage can result if proper precautions are not taken.

If more than one degree of danger is present, the warning notice representing the highest degree of danger will be used. A notice warning of injury to persons with a safety alert symbol may also include a warning relating to property damage.

### Qualified Personnel

The product/system described in this documentation may be operated only by **personnel qualified** for the specific task in accordance with the relevant documentation, in particular its warning notices and safety instructions. Qualified personnel are those who, based on their training and experience, are capable of identifying risks and avoiding potential hazards when working with these products/systems.

### Proper use of Siemens products

Note the following:

 <b>WARNING</b>
Siemens products may only be used for the applications described in the catalog and in the relevant technical documentation. If products and components from other manufacturers are used, these must be recommended or approved by Siemens. Proper transport, storage, installation, assembly, commissioning, operation and maintenance are required to ensure that the products operate safely and without any problems. The permissible ambient conditions must be complied with. The information in the relevant documentation must be observed.

### Trademarks

All names identified by ® are registered trademarks of Siemens AG. The remaining trademarks in this publication may be trademarks whose use by third parties for their own purposes could violate the rights of the owner.

### Disclaimer of Liability

We have reviewed the contents of this publication to ensure consistency with the hardware and software described. Since variance cannot be precluded entirely, we cannot guarantee full consistency. However, the information in this publication is reviewed regularly and any necessary corrections are included in subsequent editions.

# Preface

## Components of the product

The following components are supplied with a **SCALANCE X-200** IE switch:

- One device
- One 2-pin plug-in terminal block
- One 4-pin plug-in terminal block
- One DVD (configuration manual, operating instructions, Primary Setup Tool, GSD file, SNMP OPC profile)

The following components are supplied with a **SCALANCE X-200** IE switch with the **PRO** supplement:

- One device
- Protective caps for the data interfaces
- Protective caps for the connectors of the power supply
- One protective cap for the signaling contact
- One DVD (configuration manual, operating instructions, Primary Setup Tool, GSD file, SNMP OPC profile)

## Unpacking, checking

 <b>WARNING</b>
<p>Do not use any parts that show evidence of damage. If you use damaged parts, there is no guarantee that the device will function according to the specification.</p> <p>If you use damaged parts, this can lead to the following problems:</p> <ul style="list-style-type: none"><li>• Injury to persons</li><li>• Loss of the approvals</li><li>• Violation of the EMC regulations</li></ul> <p>Use only undamaged parts.</p>

1. Make sure that the package is complete.
2. Check all the parts for transport damage.

If the consignment is incomplete or damaged, contact your supplier or your local Siemens office.

## Purpose of the Operating Instructions

These operating instructions support you when commissioning networks with the devices of the product line SCALANCE X-200.

## Overview of the technical documentation of the IE Switches X-200

The technical documentation of the X-200 product line is divided into hardware and software and can be found in the following documents:

- **PH SCALANCE X-200 configuration manual**  
Software description of the X-200 product line
- **SCALANCE X-200 BA Operating Instructions**  
Hardware description for all product groups and general information.

You will find the documents here:

- On the data medium that ships with some products:
  - Product CD / product DVD
  - SIMATIC NET Manual Collection
- On the Internet pages of Siemens Industry Online Support (<http://support.automation.siemens.com/WW/view/en/33118791/133300>).

## Validity of the Operating Instructions

These operating instructions are valid for the following devices:

<b>SCALANCE X200 and SCALANCE XF200</b>	
Product name:	Order number:
X204-2	6GK5 204-2BB10-2AA3
X204-2TS	6GK5 204-2BB10-2CA2
X204-2FM	6GK5 204-2BB11-2AA3
X204-2LD	6GK5 204-2BC10-2AA3
X204-2LD TS	6GK5 204-2BC10-2CA2
X206-1	6GK5 206-1BB10-2AA3
X206-1LD	6GK5 206-1BC10-2AA3
X208	6GK5 208-0BA10-2AA3
X208PRO	6GK5 208-0HA10-2AA6
X212-2	6GK5 212-2BB00-2AA3
X212-2LD	6GK5 212-2BC00-2AA3
X216	6GK5 216-0BA00-2AA3
X224	6GK5 224-0BA00-2AA3

<b>SCALANCE X200 and SCALANCE XF200</b>	
Flat design:	
XF204	6GK5 204-0BA00-2AF2
XF204-2	6GK5 204-2BC00-2AF2
XF206-1	6GK5 206-1BC00-2AF2
XF208	6GK5 208-0BA00-2AF2

<b>SCALANCE X200IRT and XF200IRT</b>	
Product name:	Order number:
X200-4P IRT	6GK5 200-4AH00-2BA3
X201-3P IRT	6GK5 201-3BH00-2BA3
X201-3P IRT PRO	6GK5 201-3JR00-2BA6
X202-2IRT	6GK5 202-2BB00-2BA3
X202-2P IRT	6GK5 202-2BH00-2BA3
X202-2P IRT PRO	6GK5 202-2JR00-2BA6
X204IRT	6GK5 204-0BA00-2BA3
X204IRT PRO	6GK5 204-0JA00-2BA6
Flat design:	
XF204IRT	6GK5 204-0BA00-2BF2

## Purpose

The SCALANCE X-200 devices are switches for setting up Ethernet networks for industrial applications.

### Restricted area of application according to Hazardous Locations (HazLoc)

The devices are only suitable for use in the following areas:

- In areas according to Class I, Division 2, Groups A, B, C and D and in areas without explosive atmospheres.
- In areas according to Class I, Zone 2 Groups IIC and in areas without explosive atmospheres.

## Names of the devices in these operating instructions

Unless mentioned otherwise, the descriptions in these operating instructions refer to all devices of the SCALANCE X-200 product line named above in the section on Validity.

In the remainder of the instructions, these will also be referred to as **IE switches** or also simply as **X-200**.

## Further documentation

In the system manuals "Industrial Ethernet / PROFINET Industrial Ethernet" and "Industrial Ethernet / PROFINET passive network components", you will find information on other SIMATIC NET products that you can operate along with the devices of this product line in an Industrial Ethernet network.

You will find the system manuals on the Internet pages of Siemens Industry Online Support under the following entry IDs:

- 27069465 (<http://support.automation.siemens.com/WW/view/en/27069465>)  
Industrial Ethernet / PROFINET Industrial Ethernet System Manual
- 84922825 (<http://support.automation.siemens.com/WW/view/en/84922825>)  
Industrial Ethernet / PROFINET - Passive network components System Manual

## Finding information

To help orientation, there is not only a table of contents but also an Index in the Appendix.

The SIMATIC NET Glossary also provides additional help, see below.

## Audience

These operating instructions are intended for persons involved in commissioning networks in which IE switches are used.

## SIMATIC NET Selection Tool

The SIMATIC NET selection tool supports you when selecting Industrial Ethernet switches and components for Industrial Wireless Communication. You will find current information on the Product Support pages under the following entry ID:

39134641 (<http://support.automation.siemens.com/WW/view/en/39134641>)

## Where to find Siemens documentation

- Article numbers

You will find the article numbers for the Siemens products of relevance here in the following catalogs:

- SIMATIC NET - Industrial Communication / Industrial Identification, catalog IK PI
- SIMATIC - Products for Totally Integrated Automation and Micro Automation, catalog ST 70

You can request the catalogs and additional information from your Siemens representative. You will also find the product information in the Siemens Industry Mall at the following address:

(<https://mall.industry.siemens.com>)

- Manuals on the Internet

You will find SIMATIC NET manuals on the Internet pages of Siemens Industry Online Support:

10805878 (<http://support.automation.siemens.com/WW/view/en/10805878>)

Go to the required product in the product tree and make the following settings:

Entry type "Manuals"

- Manuals on the data medium

You will find manuals of SIMATIC NET products on the data medium that ships with many of the SIMATIC NET products.

## See also

Link to Customer Support (<http://support.automation.siemens.com/WW/view/en>)

## Security information

Siemens provides products and solutions with industrial security functions that support the secure operation of plants, solutions, machines, equipment and/or networks. They are important components in a holistic industrial security concept. With this in mind, Siemens' products and solutions undergo continuous development. Siemens recommends strongly that you regularly check for product updates.

For the secure operation of Siemens products and solutions, it is necessary to take suitable preventive action (e.g. cell protection concept) and integrate each component into a holistic, state-of-the-art industrial security concept. Third-party products that may be in use should also be considered. For more information about industrial security, visit <http://www.siemens.com/industrialsecurity>.

To stay informed about product updates as they occur, sign up for a product-specific newsletter. For more information, visit <http://support.automation.siemens.com>.

## **SIMATIC NET glossary**

Explanations of many of the specialist terms used in this documentation can be found in the SIMATIC NET glossary.

You will find the SIMATIC NET glossary on the Internet at the following address:

50305045 (<http://support.automation.siemens.com/WW/view/en/50305045>)

## **Trademarks**

The following and possibly other names not identified by the registered trademark sign ® are registered trademarks of Siemens AG:

SIMATIC NET, SCALANCE, C-PLUG, OLM



# Table of contents

	<b>Preface .....</b>	<b>3</b>
<b>1</b>	<b>Functions .....</b>	<b>11</b>
<b>2</b>	<b>Description of the device .....</b>	<b>15</b>
2.1	Device views .....	15
2.2	Accessories .....	17
2.3	The LEDs .....	18
2.3.1	LED display when the device starts up .....	18
2.3.2	Power LED "L" (green/yellow LED) .....	19
2.3.3	Fault LED "F" (yellow/red LED) .....	19
2.3.4	Redundancy manager LED "RM" (green LED) .....	20
2.3.5	Standby LED "RM" (yellow LED) .....	20
2.3.6	Port LEDs "P" (green/yellow LEDs) .....	21
2.3.7	Diagnostics LEDs for optical connectors "F" (yellow LED) .....	21
2.3.8	Show Location .....	22
2.4	The SET button .....	22
2.5	The C-PLUG .....	23
<b>3</b>	<b>Safety notices .....</b>	<b>27</b>
3.1	Safety notices in general .....	27
3.2	Safety notices for hazardous areas .....	28
3.3	Security recommendations .....	29
<b>4</b>	<b>Installation .....</b>	<b>35</b>
4.1	Safety notices for installation .....	35
4.2	Installation options .....	37
4.3	Installation on a DIN rail .....	38
4.4	Installation on a standard rail .....	39
4.5	Wall mounting .....	40
<b>5</b>	<b>Connecting up .....</b>	<b>41</b>
5.1	Safety when connecting up .....	41
5.2	Wiring rules .....	44
5.3	Power supply .....	45
5.3.1	Power supply via terminal block .....	45
5.3.2	Supply for X208PRO .....	46
5.3.3	Supply for IRT-PRO devices .....	46
5.4	Grounding .....	49
5.5	Signaling contact .....	50

5.6	Attachment to Industrial Ethernet.....	52
5.6.1	Electrical connections .....	52
5.6.1.1	Electrical attachments to Industrial Ethernet .....	52
5.6.1.2	Electrical connectors of the X208PRO .....	54
5.6.2	Optical attachments to Industrial Ethernet.....	56
5.6.2.1	Multimode fiber-optic cable .....	56
5.6.2.2	Single mode fiber-optic cable.....	57
5.6.2.3	POF and PCF cables .....	58
5.6.3	Push-pull connector for IRT-PRO devices .....	59
<b>6</b>	<b>Approvals .....</b>	<b>61</b>
<b>7</b>	<b>Technical specifications .....</b>	<b>69</b>
<b>A</b>	<b>Dimension drawings.....</b>	<b>79</b>
<b>B</b>	<b>Test of mechanical stability .....</b>	<b>85</b>
<b>C</b>	<b>Training, Service &amp; Support .....</b>	<b>87</b>
	<b>Index .....</b>	<b>89</b>

# Functions

## Functions of the X-200 IE Switches

The X-200 IE switches are ideally suited for setting up Industrial Ethernet networks in bus, star and ring structures with transmission rates of 10/100 Mbps. All X-200 switches operate in the SIMATIC environment.

### Hardware properties:

- X devices have a rugged metal housing and can be installed on a DIN rail, a standard rail or directly on a wall.
- XF devices have a plastic housing and a flat design. They are suitable for installation on a DIN rail.
- Redundant power supply, 2 x 24 VDC (exception: IRT-PRO devices)
- Diagnostics LED
- Signaling contact
- SET button for local configuration of the signaling contact
- Slot for C-PLUG
- Reliable plug-in connections thanks to rugged device connectors suitable for industry in conjunction with PROFINET-compliant FastConnect plugs.
- TS devices meet the railway standard EN 50155

### Software properties:

- PROFINET Diagnostics
- Topology support (LLDP)
- CLI - Command Line Interface / Telnet
- WBM - Web Based Management
- Configuration with STEP 7
- SNMP
- Ring redundancy including redundancy manager
- Passive Listening
- FM devices support the Fiber Monitoring Protocol and allow the monitoring of optical line sections.

### Special features of the X-200IRT IE switches

The IRT variants were designed specifically for setting up Industrial Ethernet networks with isochronous/clock synchronous real-time communication. In addition to the properties named above, the IRT switches also provide the following functions:

- IRT communication based on the combination of the switching methods cut through and store and forward.
- Fast media redundancy thanks to an integrated redundancy manager for Fast Ethernet.
- Standby redundancy

### Special features of the PRO variants

The devices with the "PRO" supplement are designed with degree of protection IP65 or IP67 for use outside a cabinet.

### Frame delay times

The number of IE Switches X-200 connected in a line influences the frame delay.

---

#### Note

##### Frame delay time with X-200 without IRT

When a frame passes through X-200 IE switches, it is delayed by the Store&Forward function of the X-200 IE switches.

- With a 64 byte frame length by approx. 10 microseconds (at 100 Mbps).
- With a 1500 byte frame length by approx. 130 microseconds (at 100 Mbps).

This means that the more IE Switch X-200 devices the frame passes through, the longer the frame delay.

---

#### Note

##### Frame delay time with X-200 with IRT

The more X-200IRT IE switches a frame runs through, the higher the frame delay. By using the "cut through" switching mechanism, the X-200IRT IE switches are ideal to meet the real-time requirements of PROFINET.

Cut through is, however, not possible:

- Between a port set to 10 Mbps and a port set to 100 Mbps.
- When two packets are to be sent at the same time on one port.

In this case, an X-200 IE switch changes to Store&Forward and the delay increases.

---

### Overview of the functions

The following table shows the hardware and software properties for each product variant of the X-200 switches in detail:

Device type	Hardware									Software										
	Flat design	Compact housing	Diagnostics LED	SIMATIC environment	Redundant power supply	Signaling contact	SET button	Slot for C-PLUG	Railway approval	PROFINET Diagnostics	Topology support (LLDP)	Comman Line Interface (CLI) / Telnet	Web Based Management (WBM)	Configuration with STEP 7	SNMP	Ring redundancy incl. Redundancy manager	Standby redundancy	IRT communication	Passive Listening	Fiber Monitoring Protocol
SCALANCE X-200	X204-2		•	•	•	•	•	•	•	•	•	•	•	•	•				•	
	X204-2TS		•	•	•	•	•	•	•		•	•	•	•	•	•				
	X204-2FM		•	•	•	•	•	•	•		•	•	•	•	•	•			•	•
	X204-2LD		•	•	•	•	•	•	•		•	•	•	•	•	•			•	
	X204-2LD TS		•	•	•	•	•	•	•	•	•	•	•	•	•	•			•	
	X206-1		•	•	•	•	•	•	•		•	•	•	•	•	•			•	
	X206-1LD		•	•	•	•	•	•	•		•	•	•	•	•	•			•	
	X208		•	•	•	•	•	•	•		•	•	•	•	•	•			•	
	X208PRO		•	•	•	•	•	•	•		•	•	•	•	•	•			•	
	X212-2		•	•	•	•	•	•	•		•	•	•	•	•	•			•	
	X212-2LD		•	•	•	•	•	•	•		•	•	•	•	•	•			•	
	X216		•	•	•	•	•	•	•		•	•	•	•	•	•			•	
	X224		•	•	•	•	•	•	•		•	•	•	•	•	•			•	
	XF204	•		•	•	•	•	•	•		•	•	•	•	•	•			•	
	XF204-2	•		•	•	•	•	•	•		•	•	•	•	•	•			•	
	XF206-1	•		•	•	•	•	•	•		•	•	•	•	•	•			•	
	XF208	•		•	•	•	•	•	•		•	•	•	•	•	•			•	
SCALANCE X-200IRT	X200-4P IRT		•	•	•	•	•	•		•	•	•	•	•	•	•	•	•	•	
	X201-3P IRT		•	•	•	•	•	•		•	•	•	•	•	•	•	•	•	•	
	X201-3P IRT PRO		•	•	•	•	•	•		•	•	•	•	•	•	•	•	•	•	
	X202-2IRT		•	•	•	•	•	•		•	•	•	•	•	•	•	•	•	•	
	X202-2P IRT		•	•	•	•	•	•		•	•	•	•	•	•	•	•	•	•	
	X202-2P IRT PRO		•	•	•	•	•	•		•	•	•	•	•	•	•	•	•	•	
	X204IRT		•	•	•	•	•	•		•	•	•	•	•	•	•	•	•	•	
	X204IRT PRO		•	•	•	•	•	•		•	•	•	•	•	•	•	•	•	•	
	XF204IRT	•		•	•	•	•	•		•	•	•	•	•	•	•	•	•	•	

• applies

### Number of electrical and optical connectors in the product name

The number before the hyphen in the product name indicates the number of electrical connectors. The number following the hyphen indicates the number of optical connectors of the device. For example, the switch X212-2 has twelve electrical and two optical connectors.



## Description of the device

### 2.1 Device views

#### Device view based on the example of an X204-2TS

The following figure describes the individual components of an IE switch X200.

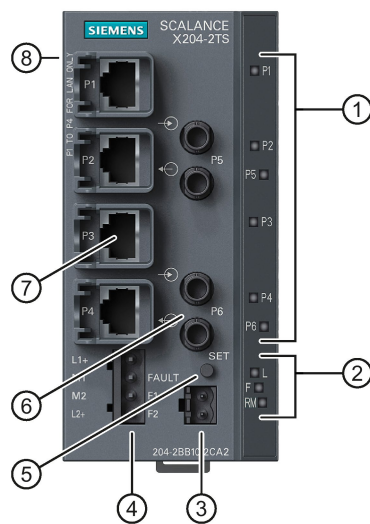

- 1 LEDs for attachments to Industrial Ethernet
- 2 LEDs
  - L: Power LED, power supply
  - F: Fault LED
  - RM: Redundancy manager or standby
- 3 Connector for signaling contact
- 4 Connector for power supply
- 5 SET button
- 6 Optical attachment to Industrial Ethernet
- 7 Electrical attachment to Industrial Ethernet
- 8 (on rear of device, not shown in figure:) Slot for C-PLUG

Device view based on the example of an X202-2P IRT PRO

The following figure describes the individual components of a PRO version of an IE switch X-200.

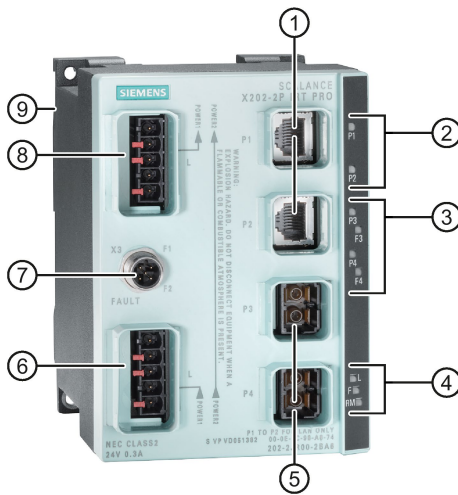

- 1 Electrical attachments to Industrial Ethernet
- 2 LEDs for electrical connectors
- 3 LEDs for optical connectors with diagnostics LEDs
- 4 LEDs
  - L: Power LED, power supply
  - F: Fault LED
  - RM:
    - green = redundancy manager
    - yellow = standby indicator
- 5 Optical attachments to Industrial Ethernet
- 6 Connector for the power supply (supplied with L1, additionally looped through to L2)
- 7 Connector for signaling contact
- 8 Power supply for further devices (looped through from L1 to L2)
- 9 (on rear of device, not shown in figure): Slot for the C-PLUG and SET button

Device view based on the example of an XF204

The following figure describes the individual components of an IE switch X-200, flat design.

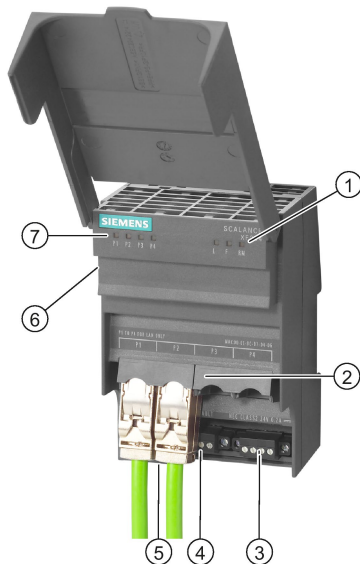

- 1 LEDs
  - L: Power LED, power supply
  - F: Fault LED
  - RM: Redundancy manager
- 2 Attachments to Industrial Ethernet
- 3 Connector for power supply
- 4 Connector for signaling contact
- 5 (behind the connectors, not shown in figure:) SET button
- 6 (on side of device, not shown in figure:) Slot for C-PLUG
- 7 LEDs for attachments to Industrial Ethernet



## 2.2 Accessories

### C-PLUG

Component	Description	Article number
C-PLUG	Configuratiioon plug, exchangeable storage medium for configuration data	6GK1 900-0AB00

### Power limiter

Component	Description	Article number
Redundancy module SITOP PSE202U NEC Class 2	Extension module for limiting the output power according to NEC Class 2 (power limiter)	6EP1 962-2BA00

### Plug Power Plug PRO

Component	Description	Article number
Power Plug PRO	5-pin push-pull-connector for installation on site 1 connector per package	6GK1 907-0AB10-6AA0

### RJ-45 data plug-in connector

Component	Description	Article number
IE FC RJ-45 PLUG PRO (push pull)	RJ-45 data plug-in connector for IE FC TP cables 2x2, IP65 1 connector per package	6GK1 901-1BB20-6AA0
IE RJ-45 PLUG PRO (push pull)	RJ-45 data plug-in connector for IE TP cables 2x2, IP65 1 connector per package	6GK1 901-1BB10-6AA0
IE FC RJ-45 PLUG 180 2x2	RJ-45 data plug-in connector for IE FC cables 2x2, 180° cable outlet 10/100 Mbps, rugged metal housing, 1 connector per package	6GK1 901-1BB10-2AA0
IE FC RJ-45 PLUG 180 2x2	RJ-45 data plug-in connector for IE FC cables 2x2, 180° cable outlet, 10/100 Mbps, rugged metal housing 10 connectors per package	6GK1 901-1BB10-2AB0
IE FC RJ-45 PLUG 180 2x2	RJ-45 data plug-in connector for IE FC cables 2x2, 180° cable outlet, 10/100 Mbps, rugged metal housing 50 connectors per package	6GK1 901-1BB10-2AE0
IE FC RJ-45 PLUG 180 4x2	RJ-45 data plug-in connector for IE FC cables 4x2 (24 AWG), 180° cable outlet, CAT6A, 10/100/1000/10000 Mbps, rugged metal housing 1 connector per package	6GK1 901-1BB12-2AA0

### 2.3 The LEDs

Component	Description	Article number
IE FC RJ-45 PLUG 180 4x2	RJ-45 data plug-in connector for IE FC cables 4x2 (24 AWG), 180° cable outlet, CAT6A, 10/100/1000/10000 Mbps, rugged metal housing 10 connectors per package	6GK1 901-1BB12-2AB0
IE FC RJ-45 PLUG 180 4x2	RJ-45 data plug-in connector for IE FC cables 4x2 (24 AWG), 180° cable outlet, CAT6A, 10/100/1000/10000 Mbps, rugged metal housing 50 connectors per package	6GK1 901-1BB12-2AE0

### SC RJ plug-in connector

Component	Description	Article number
IE SC RJ POF PLUG PRO (push pull)	SC RJ plug-in connector for POF fiber-optic cables 1 duplex connector per package	6GK1 900-0MB00-6AA0
IE SC RJ PCF PLUG PRO (push pull)	SC RJ plug-in connector for PCF fiber-optic cables 1 duplex connector per package	6GK1 900-0NB00-6AA0

## 2.3 The LEDs

### 2.3.1 LED display when the device starts up

When the X-200 starts up, the LEDs light up in the following sequence:

- The green power LED lights up immediately after turning on the device.
- The LEDs of the Ethernet connectors light up for approximately 6 seconds.
- When the Ethernet LEDs go off, the red fault LED is lit for approximately 20 seconds.
- Following this, after approximately 2 seconds the correct link status is displayed.

The X-200 is now ready for operation.

### 2.3.2 Power LED "L" (green/yellow LED)

The power LED shows the status of the power supply on the X-200 IE switch. The power LED can light up either green or yellow. The meanings of the display are as follows:

LED color	LED status	Meaning
Green	Lit	Both power supplies are connected; in other words, redundant power supply.
Yellow	Lit	Only one power supply is connected.
-	Off	No power supply is connected or the voltage is < 14 VDC or with TS devices < 8 VDC.

#### Note

The following devices do not have a redundant power supply:

- X201-3P IRT PRO
- X202-2P IRT PRO
- X204IRT PRO

### 2.3.3 Fault LED "F" (yellow/red LED)

The fault LED indicates a fault/error on the X-200. If the X-200 detects an error, the signaling contact is opened at the same time assuming that the response of the signaling contact was not configured differently.

The meanings of the fault LED display are as follows:

LED color	LED status	Meaning
Yellow	Lit	The LED can only adopt this status with FM devices. Check the received power or the loss of power on optical connections. If necessary, replace the parts.
Red	Lit	The fault LED lighting up can have the following meanings: <ul style="list-style-type: none"> <li>• Link down event on a monitored port</li> <li>• Loss of the power supply</li> <li>• C-PLUG error</li> <li>• Device is in PROFINET mode: <ul style="list-style-type: none"> <li>– There is no connection to the controller.</li> <li>– There is a connection to the controller. A configured diagnostics interrupt is also pending, for example power fail interrupt, C-PLUG interrupt etc.</li> </ul> </li> <li>• Redundancy manager connected through</li> <li>• Switchover of standby connection</li> <li>• A defined value was undershot in a monitored optical connection.</li> <li>• A loop was detected.</li> <li>• Device startup. The LED lights up for approximately 20 seconds.</li> </ul>
Red	Flashing	Internal error detected. Notify maintenance personnel. If necessary, send the device in for repair.
-	Off	No error detected.

### 2.3.4 Redundancy manager LED "RM" (green LED)

The green LED shows the following statuses of the X-200:

LED color	LED status	Meaning
Green	Lit	The device is operating in the role of redundancy manager. The ring is operating free of errors. The monitoring is enabled.
Green	Flashing	The device is operating in the role of redundancy manager. An interruption was detected in the ring. The device has switched through.
-	Off	The device is not operating in the role of redundancy manager.

---

#### Note

This LED labeled on the device with "RM" has a dual function. The color of the display changes depending on the function:

- If the LED is lit green, the redundancy manager function is indicated.
- If the LED is lit yellow, the standby function is indicated.

In Web Based Management (WBM), the LED is labeled differently depending on the function:

- The redundancy manager function (as shipped) is labeled "RM".
  - The standby function is labeled "SB" in the WBM.
- 

### 2.3.5 Standby LED "RM" (yellow LED)

You will find the standby LED only on devices with the IRT function.

---

#### Note

This LED labeled on the device with "RM" has a dual function. The color of the display changes depending on the function:

- If the LED is lit green, the redundancy manager function is indicated.
- If the LED is lit yellow, the standby function is indicated.

In Web Based Management (WBM), the LED is labeled differently depending on the function:

- The redundancy manager function (as shipped) is labeled "RM".
  - The standby function is labeled "SB" in the WBM.
-

The yellow LED indicates the following statuses of the X-200IRT:

LED color	LED status	Meaning
Yellow	Lit	The standby function is activated, the switch is in active mode.
Yellow	Flashes slowly	The standby function is activated, the switch is in passive mode.
Yellow	Flashes quickly	Standby partner lost.
-	Off	The standby function is not activated.

### 2.3.6 Port LEDs "P" (green/yellow LEDs)

The LEDs of the Ethernet connectors can be lit green or yellow. The meanings of the display are as follows:

LED color	LED status	Meaning
Green	Lit	Link exists, no data reception
Yellow	Lit	Link exists, data being received Device startup. The LED lights up for approximately 6 seconds.
Yellow	Flashing	Setting or display of the fault mask

The following statuses of the port LEDs do not exist on devices with the IRT function:

LED color	LED status	Meaning
Green	flashes once per period	Link exists and port in "blocking" status. In this status, the port only receives management data (no user data).
Green	flashes three times per period	Link exists and port is deactivated by the management. In this status, no data is sent or received via the port.
Green	flashes four times per period	Port exists and is in the "monitor port" status. In this status, the data traffic of another port is mirrored to this port.

### 2.3.7 Diagnostics LEDs for optical connectors "F" (yellow LED)

You will find the diagnostics LEDs only on the devices with the IRT function.

The status of the optical connectors is indicated by an additional yellow LED per connector. The LEDs signal the following statuses:

LED color	LED status	Meaning
Yellow	Lit	Check the plug-in connection and the quality of the fiber-optic cable. If necessary, replace the parts.
-	Off	Relevant only if the link exists. The existing link power margin is adequate for error-free operation.

### 2.3.8 Show Location

#### Localizing an IE Switches X-200

To identify an IE Switch X-200 locally and with certainty, you can use the "show location" function on a programming device to select the node over the network and make it flash. This can be used, for example, when assigning addresses to make sure that the correct node receives the address. All port LEDs of the addressed node flash green at 2 Hz.

With the Primary Setup Tool (PST) V3.0 or higher, you can trigger this function with "Module \ Flash".

## 2.4 The SET button

### Function of the SET button

With the SET button, you can change various settings of the device. The changed settings remain after cycling power to the device.

Different settings are made depending on how long you hold down the SET button, as described in the following table:

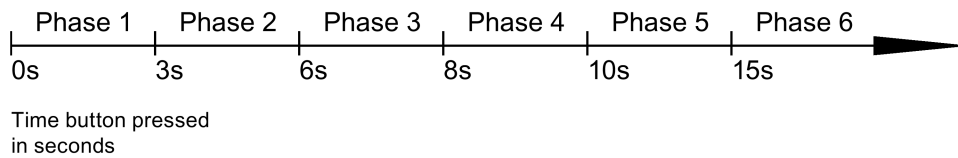

Image 2-1 Phases for changing settings using the SET button

Phase	Description
1	The currently set fault mask is displayed. If no fault mask has been set, all ports flash one after the other. If you release the button in phase 1, this has no effect.
2	The LEDs of the ports at which there is currently a link flash at 2.5 Hz. If you release the button in phase 2, this has no effect.
3	The LEDs of the ports at which there is currently a link and the LEDs of the connected power supply are lit permanently. If you release the button in phase 3, the fault mask corresponding to the lit LEDs is adopted.
4	The RM LED flashes. If you release the button in phase 4, the redundancy manager is deactivated. The redundancy function remains enabled. The device changes to "Automatic Redundancy Detect" mode.

Phase	Description
5	The RM LED is lit permanently. If you release the button in phase 5, the redundancy function is activated and the device is configured as HRP manager.
6	All LEDs flash. The device is reset to the factory defaults.

## 2.5 The C-PLUG

### Area of application

The C-PLUG is an exchangeable medium for storage of the configuration and project engineering data of the basic device. This means that the configuration data remains available if the basic device is replaced.

### How it works

Power is supplied by the basic device. The C-PLUG retains all data permanently when the power is turned off.

If an empty C-PLUG (factory settings) is inserted, all configuration data of an IE Switch X-200 is saved to it when the device starts up. Changes to the configuration during operation are also saved on the C-PLUG without any operator intervention being necessary.

If a C-PLUG is inserted, the configuration stored internally on the basic device is no longer changed. All changes made to the configuration during ongoing operation are only stored on the C-PLUG.

A basic device with an inserted C-PLUG automatically uses the configuration data of the C-PLUG when it starts up. This is, however, only possible when the data was written by a compatible device type.

This allows fast and simple replacement of the basic device. If a device is replaced, the C-PLUG is taken from the failed component and inserted in the replacement device. The first time it is started up, the replacement device has the same configuration as the failed device except for the MAC address set by the vendor.

### Compatible devices

As a general rule, the data on the C-PLUG is only compatible with devices having an identical order number and the same device name.

2.5 The C-PLUG

The device combinations shown in the following table are exceptions. With these devices, the exchange of the C-PLUG is possible in one direction.

Device type	C-PLUG created by device with order number		Compatible with device with order number
X204-2	6GK5 204-2BB00-2AA3	➔	6GK5 204-2BB10-2AA3
X204-2LD	6GK5 204-2BC00-2AA3		6GK5 204-2BC10-2AA3
X206-1	6GK5 206-1BB00-2AA3		6GK5 206-1BB10-2AA3
X206-1LD	6GK5 206-1BC00-2AA3		6GK5 206-1BC10-2AA3
X208	6GK5 208-0BA00-2AA3		6GK5 208-0BA10-2AA3
X208PRO	6GK5 208-0HA00-2AA6		6GK5 208-0HA10-2AA6

**Note**

Combinations other than those shown in the table are not compatible with each other.

**Note**

If you insert a C-PLUG in a compatible device, the system name of the original device is entered both in the system name as well as in the PROFINET IO device name of the compatible device.

**Using a previously written C-PLUG**

If you want to insert a C-PLUG that has already been used and written to into a new differently configured X-200 IE switch, you will first need to delete the existing data on the C-PLUG. You will find information about this in the configuration manual of the SCALANCE X-200 in the section on the WBM menu items.

**Note**

The X-200 IE switches normally start up with the configuration of the C-PLUG, assuming this was written to by a compatible device type. If the C-PLUG was written to by an incompatible device type, the basic device will not start up fully and signals an error. The WBM menu "System C-PLUG" is displayed automatically. Here, use the "Modify C-PLUG" function to specify whether or not the device operates with a C-PLUG.

If you operate a device with a C-PLUG, the C-PLUG can either be initialized with the factory settings or with the settings stored internally on the device.



## Diagnostics

The following events are signaled by the diagnostics mechanisms of the X-200, such as LEDs, WBM etc.:

- Inserting a C-PLUG that contains the configuration of an incompatible device type.
- The accidental removal of a C-PLUG
- General malfunctions of the C-PLUG.

## The C-PLUG does not ship with the product

The C-PLUG is not supplied with the IE switches X-200, see section “Accessories (Page 17)”.

## Inserting in the slot

### NOTICE

- Insert and remove the C-PLUG only when power is off.
- In a device with a varnished printed circuit board, you may only use a C-PLUG with a varnished board.



Image 2-2 C-PLUG and slot

## *2.5 The C-PLUG*

The slot for the C-PLUG is located as follows:

- On the IE Switch X-200 on the back of the device.
- On the IE Switch XF-200 on the left hand side of the device.

Follow the steps below to insert the C-PLUG:

1. Remove the screw cover.
2. Insert the C-PLUG in the slot.
3. Close the slot with the screw cover.

### **Removing the C-PLUG**

It is only necessary to remove the C-PLUG if the IE Switch X-200 develops a fault.

You can lever the C-PLUG out of the slot carefully using flat pliers, tweezers, or a small screwdriver.

If no C-PLUG is inserted in the device, when the device restarts, an error message is output in Web Based Management and in the Command Line Interface. In this case, you will need to set the device to operation without C-PLUG. For further information, refer to the section "System C-PLUG" in the section on the WBM menu in the configuration manual.

# Safety notices

## 3.1 Safety notices in general

Note the following safety notices. These relate to the entire working life of the device.

 <b>WARNING</b>
<b>Do not use any parts that show evidence of damage</b>
If you use damaged parts, there is no guarantee that the device will function according to the specification.
If you use damaged parts, this can lead to the following problems:
<ul style="list-style-type: none"><li>• Injury to persons</li><li>• Loss of the approvals</li><li>• Violation of the EMC regulations</li><li>• Damage to the device and other components</li></ul>
Use only undamaged parts.

### Installation guidelines

The product meets the requirements if you adhere to the installation and safety notices contained in this documentation and in the following documentation when installing and operating the product.

#### Current documentation on the Internet

The current descriptions of the currently available products can be found on the Product Support pages under the entry IDs below:

- Configuration manual SIMATIC NET PH SCALANCE X-200 63203259 (<http://support.automation.siemens.com/WW/view/en/63203259>)
- System manual SIMATIC NET Industrial Ethernet Network Manual 27069465 (<http://support.automation.siemens.com/WW/view/en/27069465>)
- Configuration manual EMC Installation Guidelines 60612658 (<http://support.automation.siemens.com/WW/view/en/60612658>)

### Special safety notices

You should also read the safety notices relating to handling in the individual sections, particularly in the sections "Installation" and "Connecting up".

### Electrostatic discharge



**NOTICE**

**Electrostatic sensitive devices (ESD)**

Electronic modules contain electrostatic sensitive components

These components can easily be destroyed if handled incorrectly.

Note the following instructions to avoid damage.

- Touch electronic modules only when you absolutely need to work on them.
- If electronic modules need to be touched, the body of the person involved must first be electrostatically discharged and grounded.
- Do not bring electronic modules in contact with electrically isolating materials such as plastic film, isolating table top pads or clothing made of synthetic fibers.
- Place the modules only on conductive surfaces.
- Pack, store and transport electronic modules and components only in conductive packaging such as metalized plastic or metal containers, conductive foam or household aluminum foil.

## 3.2 Safety notices for hazardous areas

### Safety notices on use in hazardous areas

#### General safety notices relating to protection against explosion



**WARNING**

**EXPLOSION HAZARD**

Do not open the device when the supply voltage is turned on.

#### Safety notices when using the device according to Hazardous Locations (HazLoc)

If you use the device under HazLoc conditions you must also keep to the following safety notices in addition to the general safety notices for protection against explosion:

This equipment is suitable for use in Class I, Division 2, Groups A, B, C and D or non-hazardous locations only.

This equipment is suitable for use in Class I, Zone 2, Group IIC or non-hazardous locations only.

## 3.3 Security recommendations

<b>NOTICE</b>
<b>Information security</b> Connect to the device and change the standard passwords for the users "admin" and "user" before you operate the device. To be able to change passwords you need to be logged in with write access to the configuration data.

To prevent unauthorized access, note the following security recommendations.

### General

- You should make regular checks to make sure that the device meets these recommendations and/or other security guidelines.
- Evaluate your plant as a whole in terms of security. Use a cell protection concept with suitable products.
- When confidential zones are used, the internal and external network are disconnected, an attacker cannot access the data from the outside.
- Operate the device only within a protected network area.
- Use VPN to encrypt and authenticate communication from and to the devices.
- For data transmission via a non-secure network use an encrypted VPN tunnel (IPsec).
- For operation of the device in a non-secure infrastructure no product liability will be accepted.
- Separate connections correctly (WBM, Telnet, SSH etc.).

### Physical access

- Limit physical access to the device to qualified personnel.  
The memory card or the C-PLUG contains sensitive data such as certificates, keys etc. that can be read out and modified.
- Lock unused physical ports on the device. Unused ports can be used to gain forbidden access to the plant.

### Software (security functions)

- Keep the software up to date. Check regularly for security updates of the product. You will find information on this on the Internet pages "Industrial Security (<http://www.siemens.com/industrialsecurity>)"
- Inform yourself regularly about security advisories and bulletins published by Siemens productCERT (<http://www.siemens.com/cert/en/cert-security-advisories.htm>).
- Only activate protocols that you really require to use the device.

### 3.3 Security recommendations

- Restrict access to the device with a firewall or rules in an access control list (ACL - Access Control List).
- Restrict access to the management of the device with rules in an access control list (ACL).
- The option of VLAN structuring provides good protection against DoS attacks and unauthorized access. Check whether this is practical or useful in your environment.
- Enable logging functions. Use the central logging function to log changes and access attempts centrally. Check the logging information regularly.
- Configure a Syslog server to forward all logs to a central location.

#### Passwords

- Define rules for the use of devices and assignment of passwords.
- Regularly update passwords and keys to increase security.
- Change all default passwords for users before you operate the device.
- Only use passwords with a high password strength. Avoid weak passwords for example password1, 123456789, abcdefgh.
- Make sure that all passwords are protected and inaccessible to unauthorized personnel.
- Do not use the same password for different users and systems or after it has expired.

#### Keys and certificates

This section deals with the security keys and certificates you require to set up SSL.

- We strongly recommend that you create your own SSL certificates and make them available.

There are preset certificates and keys on the device. The preset and automatically created SSL certificates are self-signed. We recommend that you use SSL certificates signed either by a reliable external or by an internal certification authority.

The device has an interface via which you can import the certificates and keys.

- Use the certification authority including key revocation and management to sign the certificates.
- Handle user-defined private keys with great caution if you use user-defined SSH or SSL keys.
- Verify certificates and fingerprints on the server and client to avoid "man in the middle" attacks.
- We recommend that you use certificates with a key length of 2048 bits.
- Change keys and certificates immediately, if there is a suspicion of compromise.

## Secure/non-secure protocols

- Avoid or disable non-secure protocols, for example Telnet and TFTP. For historical reasons, these protocols are still available, however not intended for secure applications. Use non-secure protocols on the device with caution.
- Avoid or disable non-secure protocols. Check whether use of the following protocols is necessary:
  - PROFINET
  - Broadcast pings
  - Non authenticated and unencrypted interfaces
  - ICMP (redirect)
  - MRP, HRP
  - LLDP
  - DHCP Options 66/67

The following protocols provide secure alternatives:

- SNMPv1/v2 → SNMPv3

Check whether use of SNMPv1 is necessary. SNMPv1 is classified as non-secure. Use the option of preventing write access. The product provides you with suitable setting options.

If SNMP is enabled, change the community names. If no unrestricted access is necessary, restrict access with SNMP.

Use SNMPv3 in conjunction with passwords.

- HTTP → HTTPS
- TFTP → FTPS
- Telnet → SSH
- SNTP → NTP
- Use secure protocols when access to the device is not prevented by physical protection measures.
- To prevent unauthorized access to the device or network, take suitable protective measures against non-secure protocols.
- If you require non-secure protocols and services, operate the device only within a protected network area.
- Restrict the services and protocols available to the outside to a minimum.
- For the DCP function, enable the "DCP read-only" mode after commissioning.

### Available protocols per port

The following list provides you with an overview of the open ports on this device. Keep this in mind when configuring a firewall.

The table includes the following columns:

- **Protocol**  
All protocols that the device supports
- **Port number**  
Port number assigned to the protocol
- **Port status**
  - Open  
The port is always open and cannot be closed.
  - Open (when configured)  
The port is open if it has been configured.

---

**Note**

With some protocols the port may be open although the corresponding protocol is disabled, for example TFTP.

---

- **Default status of the port**
  - Open  
As default the port is open.
  - Closed  
As default the port is closed.
- **Authentication**  
Specifies whether or not the protocol is authenticated during access.

Protocol	Port number	Port status	Default status of the port	Authentication
SSH	TCP/22	Open	Open	Yes
HTTP	TCP/80	Open	Open	Yes
HTTPS	TCP/443	Open	Open	Yes
SNTP NTP (secure)	UDP/123	Open (when configured)	Closed	No
SNMP	UDP/161	Open (when configured)	Open	Yes
PROFINET IO	UDP/34964 UDP/1026, 1027 *)	Open	Open	No
PROFINET IO Service	TCP/84	Open	Open	No
TELNET	TCP/23	Open (when configured)	Open	Yes



Protocol	Port number	Port status	Default status of the port	Authentication
DHCP	UDP/67, 68	Open (when configured)	Closed	No
TFTP	UDP/69	Open (when configured)	Closed	No

\*) These ports are assigned dynamically and can differ from the values specified here.



# Installation

## 4.1 Safety notices for installation

### Safety notices

When installing the device, keep to the notices listed below.

 **WARNING**

**When used in ships, a DIN rail does provide adequate support**

For the following devices, installation on a 35 mm DIN rail for use in ships is not permitted:

- X201-3P IRT PRO
- X202-2P IRT PRO
- X204IRT PRO
- X208PRO
- X212-2
- X212-2LD
- X216
- X224

In ships, the DIN rail does not provide adequate support.

 **WARNING**

If a device is operated in an ambient temperature of more than 50 °C, the temperature of the device housing may be higher than 70 °C. The device must therefore be installed so that it is only accessible to service personnel or users that are aware of the reason for restricted access and the required safety measures at an ambient temperature higher than 50 °C.

 **WARNING**

If the cable or conduit entry point exceeds 70 °C or the branching point of conductors exceeds 80 °C, special precautions must be taken. If the equipment is operated in an air ambient in excess of 50 °C, only use cables with admitted maximum operating temperature of at least 80 °C.

### Safety notices on use in hazardous areas

#### General safety notices relating to protection against explosion

 <b>WARNING</b>
The device may only be operated in an environment with pollution degree 1 or 2 (see IEC 60664-1).

 <b>WARNING</b>
When used in hazardous environments corresponding to Class I, Division 2 or Class I, Zone 2, the device must be installed in a cabinet or a suitable enclosure.

 <b>WARNING</b>
<b>EXPLOSION HAZARD</b>
Replacing components may impair suitability for Class 1, Division 2 or Zone 2.

#### Safety notices for use according to ATEX and IECEx

If you use the device under ATEX or IECEx conditions you must also keep to the following safety notices in addition to the general safety notices for protection against explosion:

 <b>WARNING</b>
To comply with EU Directive 94/9 (ATEX95), this enclosure or the cabinet must meet the requirements of at least IP54 in compliance with EN 60529.

#### Devices with approval [op is Gb] for optical ports

Some devices have an additional ATEX approval according to II 3 (2) G Ex nA [op is Gb] IIC T4 and an additional IECEx approval according to Ex nA [op is Gb] IIC T4 Gc, refer to the section Approvals (Page 61). This is indicated on the type plate. With these devices the FO bus connections may run through or in a Zone 1 hazardous area.

## Further notes

**NOTICE****Warming and premature aging of the IE switch due to direct sunlight**

Direct sunlight can heat up the device and can lead to premature aging of the IE switch and its cabling.

Provide suitable shade to protect the IE switch against direct sunlight.

**Note****Note the mounting position for XF and TS devices**

With the following IE switches, an ambient temperature of maximum +40 °C is permitted if the device is installed on a vertical rail:

- X204-2TS
- X204-2LD TS
- XF204
- XF204-2
- XF206-1
- XF208
- XF204IRT

## 4.2 Installation options

### Types of installation

IE Switches X-200 can be installed in the following ways:

- Installation on a 35 mm DIN rail complying with DIN EN 60715
- Installation on a SIMATIC S7-300 standard rail
- Wall mounting

Unless stated otherwise, the mounting options listed below apply to all X-200 IE switches.

**Exception XF-200**

The XF devices (flat design) can only be installed on a 35 mm DIN rail.

## 4.3 Installation on a DIN rail

### Installation



Image 4-1 Installation on a 35 mm DIN rail

To install an X-200 on a 35 mm DIN rail complying with DIN EN 60715, follow the steps below:

1. Place the upper catch of the device over the top of the DIN rail and then push in the lower part of the device against the rail until it clips into place.
2. Fit the connectors for the power supply.
3. Fit the connectors for the signaling contact
4. Insert the terminal blocks or M12 cable connectors into the sockets on the device.

### Removal



Image 4-2 Removing from a 35 mm DIN rail

To remove an X-200 from a DIN rail, follow the steps below:

1. First disconnect all connected cables.
2. Use a screwdriver to release the lower DIN rail catch of the device and pull the lower part of the device away from the rail.

## 4.4 Installation on a standard rail

### Installation on a SIMATIC S7-300 standard rail

To install an X-200 on a standard rail, follow the steps below:

1. Fit the housing guide on the top of the housing into the standard rail.
2. Screw the X-200 to the underside of the standard rail.
3. Fit the connectors for the power supply.
4. Fit the connectors for the signaling contact.
5. Insert the terminal blocks or M12 cable connectors into the sockets on the X-200.



Image 4-3 Installation on a SIMATIC S7-300 standard rail

### Removal

To remove an X-200 from a standard rail, follow the steps below:

1. First disconnect all connected cables.
2. Release the screws on the bottom of the standard rail.
3. Then lift the X-200 away from the standard rail.

## 4.5 Wall mounting

### Wall mounting

---

**Note**

The wall mounting must be capable of supporting at least four times the weight of the X-200, see section Technical specifications (Page 69).

---

When mounting on a wall, use mounting fittings suitable for the type of wall. To secure the device in concrete, you could, for example use the following material:

- 4 wall plugs, 6 mm in diameter and 30 mm long
- 4 screws 3.5 mm in diameter and 40 mm long

Follow the steps below to install the X-200 on a wall:

1. Prepare the drill holes for wall mounting.  
You will find the precise dimensions in the Appendix Dimension drawings (Page 79).
2. Connect the electrical cable connecting cables.
3. Fit the connectors for the signaling contact.
4. Insert the terminal blocks or M12 cable connectors into the sockets on the IE Switch X-200.
5. Screw the device to the wall.



## Connecting up

### 5.1 Safety when connecting up

#### Safety notices

When connecting up the device, keep to the safety notices listed below.

 **WARNING**

The equipment is designed for operation with Safety Extra-Low Voltage (SELV) by a Limited Power Source (LPS).

This means that only SELV / LPS complying with IEC 60950-1 / EN 60950-1 / VDE 0805-1 must be connected to the power supply terminals. The power supply unit for the equipment power supply must comply with NEC Class 2, as described by the National Electrical Code (r) (ANSI / NFPA 70).

If the equipment is connected to a redundant power supply (two separate power supplies), both must meet these requirements.

---

**Note**

**Limitation of the output voltage according to NEC Class 2 by redundancy module**

To meet the requirements according to NEC Class 2, you can use a power supply with SELV along with a power limiter, see e.g. the section "Accessories (Page 17)".

---

**Note**

**Safety extra-low voltage**

The supply of the devices by PELV (Protective Extra Low Voltage) according to DIN VDE 0100-410 or IEC 60364-4-41 is permitted when the generated nominal voltage does not exceed the voltage limits 25 VAC or 60 VDC.

---

### Safety notices on use in hazardous areas

#### General safety notices relating to protection against explosion

 <b>WARNING</b>
<b>EXPLOSION HAZARD</b>
Do not connect or disconnect cables to or from the device when a flammable or combustible atmosphere is present.

#### Exceptions

For the devices listed below, there are no requirements according to NEC Class 2 or LPS. For these devices, note the conditions described in the section Supply for IRT-PRO devices (Page 46).

- X201-3P IRT PRO
- X202-2P IRT PRO
- X204IRT PRO

#### Safety notices when using the device according to Hazardous Locations (HazLoc)

If you use the device under HazLoc conditions you must also keep to the following safety notices in addition to the general safety notices for protection against explosion:

 <b>WARNING</b>
<b>EXPLOSION HAZARD</b>
DO NOT DISCONNECT WHILE CIRCUIT IS LIVE UNLESS AREA IS KNOWN TO BE NON-HAZARDOUS.

#### Safety notices for use according to ATEX and IECEx

If you use the device under ATEX or IECEx conditions you must also keep to the following safety notices in addition to the general safety notices for protection against explosion:

 <b>WARNING</b>
Take measures to prevent transient voltage surges of more than 40% of the rated voltage. This is the case if you only operate devices with SELV (safety extra-low voltage).

## Further notes

 **WARNING**

If the cable or conduit entry point exceeds 70 °C or the branching point of conductors exceeds 80 °C, special precautions must be taken. If the equipment is operated in an air ambient in excess of 50 °C, only use cables with admitted maximum operating temperature of at least 80 °C.

 **CAUTION****Electric shock - turn off the power supply**

Turn off the power supply before you connect or disconnect cables from the device.

**NOTICE****Overvoltage protection**

If IE Switches X-200 are supplied over long 24 V power supply lines or networks, measures are necessary to prevent interference by strong electromagnetic pulses on the supply lines. These can result, for example, due to lightning or switching of large inductive loads.

One of the tests used to attest the immunity of devices of the IE Switches X-200 to electromagnetic interference was the "surge immunity test" according to EN61000-4-5. This test requires overvoltage protection for the power supply lines. A suitable device is, for example, the Dehn Blitzductor BVT AVD 24 V type no. 918 422 or a comparable protective element.

Manufacturer: DEHN+SÖHNE GmbH+Co.KG, Hans-Dehn-Str.1, Postfach 1640, D-92306 Neumarkt, Germany.

## 5.2 Wiring rules

When wiring use cables with the following AWG categories or cross sections.

Wiring rules for ...		Screw/spring-loaded terminals
connectable cable cross sections for flexible cables ...	without wire end ferrule	0.2 - 2.5 mm <sup>2</sup> AWG: 24 - 13
	with wire end ferrule with plastic ferrule**	0.25 - 2.5 mm <sup>2</sup> AWG: 24 - 13
	with wire end ferrule without plastic ferrule**	0.25 - 2.5 mm <sup>2</sup> AWG: 24 - 13
	with TWIN wire end ferrule**	0.5 - 1 mm <sup>2</sup> AWG: 20 - 17
Stripped length of the cable		8 - 10 mm
Wire end ferrule according to DIN 46228 with plastic ferrule**		8 - 10 mm

\* AWG: American Wire Gauge

\*\* See note "Wire end ferrules"

### Note

#### Wire end ferrules

Use crimp shapes with smooth surfaces, such as provided by square and trapeze shaped crimp cross sections.

Crimp shapes with wave-shaped profile are unsuitable.

## 5.3 Power supply

### 5.3.1 Power supply via terminal block

#### Power supply

The power supply is connected via a 4-pin plug-in terminal block that ships with the device.

- The power supply can be connected redundantly.
  - Both inputs are isolated.
  - No load distribution.
  - The power supply unit with the higher output voltage supplies the device alone.
- Power: 24 VDC
- Cable cross section for X-200: 2.5 mm<sup>2</sup>
- Cable cross section for XF-200: 1.5 mm<sup>2</sup>
- The power supply is connected over a high resistance with the enclosure to allow an ungrounded set up.
- The power supply is non-floating.
- The signal cables of the electrical Ethernet interfaces are floating.

The following table shows the pin assignment:

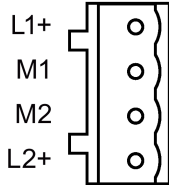
Assignment	
L1+: 24 VDC	
<b>With TS devices:</b> L1+: 12 to 24 VDC	
M1: Ground	
M2: Ground	
L2+ 24 VDC	
<b>With TS devices:</b> L2+ 12 to 24 VDC	

#### Note

##### Special features with X208PRO and the IRT-PRO devices

Note the special requirements for the power supply for the devices in the following sections.

### 5.3.2 Supply for X208PRO

#### Power supply for X208PRO

With the IE switch SCALANCE X208PRO, the power supply is connected via two 4-pin a-coded M12 sockets.

- The power supply can be connected redundantly.
  - Both inputs are isolated.
  - No load distribution.
  - The power supply unit with the higher output voltage supplies the device alone.
- Power: 24 VDC
- The power supply is connected over a high resistance with the enclosure to allow an ungrounded set up.
- The power supply is non-floating.
- The signal cables of the electrical Ethernet interfaces are floating.

The following table shows the pin assignment:

Pin no.:	Assignment
1	L1 or L2: 24 VDC
2	n. c.
3	M1 or M2
4	n. c.

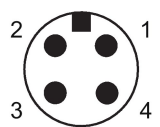

### 5.3.3 Supply for IRT-PRO devices

#### Power supply for the devices of the IRT PRO version

The following descriptions of the power supply apply to the following devices:

- X201-3P IRT PRO
- X202-2P IRT PRO
- X204IRT PRO

The power supply is connected via the push-pull Power Plug PRO. This plug has a high degree of protection (IP65) and is suitable for use outside cabinets and complies with PROFINET connector technology.

The Power Plug PRO does not ship with the device, see the section “Accessories (Page 17)“:

## Power supply

- Power: 24 VDC
- The power supply is connected over a high resistance with the enclosure to allow an ungrounded set up.
- The power supply is non-floating.
- The signal cables of the electrical Ethernet interfaces are floating.

---

### Note

#### No redundant power supply

Since the IRT PRO version of the devices does not have a redundant power supply, connect the power supply to L1 and N1.

---

### Note

#### Plug in metal casing

- If the devices are operated at an ambient temperature in excess of 40 °C or if currents higher than 6 A flow via the connector, the connector with the metal casing must be used.
  - In areas subject to the National Electric Code (NEC), the Canadian Electric Code (CEC) and the EC directive 94/9 (ATEX) and IECEx, metal connectors must be used.
- 

### Note

#### Maximum current 16 A

The current through the Power Plug PRO must not exceed 16 A. You should therefore include a fuse that trips at a current higher than 16 A.

In areas subject to the NEC or CEC, the fuse must meet the following requirements:

- Suitable for DC (min. 60 V / max. 16 A)
- Breaking current at least 10 kA
- UL / CSA listed (UL 248-1 / CSA 22.2 No. 248.1)
- Classes R, J, L, T or CC.

Otherwise the following requirements must be met:

- Suitable for DC (min. 60 V / max. 16 A)
  - Breaking current at least 10 kA
  - Approved according to IEC/EN 60127-1
  - Breaking characteristics
    - With circuit breakers: B or C
    - With fuses: slow blow
-

### Power supply looped through

The devices also have a connector for the switched mode and unswitched power supply of other devices with 24 VDC. Via these interfaces (L1+, N1 and L2+, N2) it is possible to loop the power through with connector technology compliant with PROFINET.

**Note**

**Notes on operating under marginal conditions**

When looping through the power supply, take into account the limit values; in other words, the maximum permitted current depending on the ambient temperature; refer to the table "Operation under marginal conditions" below.

When looping through the power supply under the marginal conditions described below, the device may only be operated if it is installed horizontally. Horizontal installation position means that the device is mounted, for example on a horizontal DIN or standard rail or that the labeling on the device can be read in the normal reading direction.

If no power is looped through, any installation position is permitted.

Table 5- 1 Operation under marginal conditions

Environment	Max Power 1 (L1+, N1)	Max Power 2 (L2+, N2)
+40°C	16 A	16 A
+50°C	12 A	12 A
+60°C	8 A	8 A
SCALANCE X204IRT PRO only:		
+70°C	6 A	6 A

### Pin assignment of the connectors

The following table shows the pin assignment of the two power supply connectors:

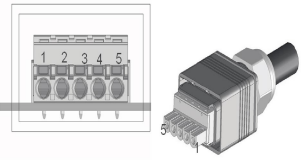
Pin no.:	Assignment	
1	L1: 24 VDC	
2	N1	
3	L2: 24 VDC	
4	N2	
5	FE (Functional Earth)	



## **5.4 Grounding**

### **Grounding when installing on a DIN rail**

The device is grounded over the DIN rail.

### **Grounding when installing on an S7 standard rail**

The device is grounded over its rear panel and the neck of the screw.

### **Grounding with wall mounting**

The device is grounded by the securing screw in the unpainted hole.

Please note that X-200 IE switches must be grounded over one securing screw with minimum resistance.

If an IE Switch X-200 is mounted on a non-conducting base, a grounding cable must be installed. The grounding cable is not supplied with the device. Connect the paint-free surface of the device to the nearest grounding point using the grounding cable.

## 5.5 Signaling contact

### Signaling contact

The signaling contact or relay contact is a floating switch with which error/fault states can be signaled by breaking the contact.

The following errors/faults can be signaled by the signaling contact:

- The loss and the establishment of a link on a monitored port.
- The failure of one of the two redundant power supplies.  
Note: Devices of the IRT PRO version do not have a redundant power supply
- The loss of the connection to the controller in PROFINET IO mode.
- The redundancy manager signals an error
- An incompatible C-PLUG was inserted.

The connection or disconnection of a communication node on an unmonitored port does not lead to an error message.

The signaling contact remains activated until the error/fault is eliminated or until the current status is applied as the new desired status using the SET button.

When the IE Switch X-200 is turned off, the signaling contact is always activated, i.e. opened.

**NOTICE**

**Load on the signaling contact**

The signaling contact can be subjected to a **maximum** load of **100 mA** (safety extra-low voltage (SELV), 24 VDC).

### Connection via 2-pin terminal block

The signaling contact is connected to a 2-pin plug-in terminal block.

The following table shows the pin assignment:

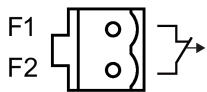
Assignment	
F1: Fault contact 1	
F2: Fault contact 2	

### Connection via M12 socket

With the X-200 IRT PRO devices and with the X208PRO, the connection is via a 5-pin, b-coded M12 socket.

The following table shows the pin assignment:

Pin no.:	Assignment	
1	F1	
2	n.c.	
3	n.c.	
4	F2	
5	n.c.	

## 5.6 Attachment to Industrial Ethernet

---

### Note

#### Redundancy mechanisms

If you use redundancy mechanisms such as media redundancy "HRP" or "MRP" and/or redundant linking of rings via a standby link, remember the following:

Open the redundant path before you insert a new device or replacement device in an operating network. A bad configuration or attachment of the Ethernet cables to incorrectly configured ports causes overload in the network and a breakdown in communication.

A device may only be inserted in a network and connected in the following situations:

- HRP / MRP
  - The ring ports of the device being inserted in the ring were configured as ring ports.
  - The required redundancy mode is also enabled.
  - If the device is intended to operate as the redundancy manager, "Enable Ring Redundancy" must also be set.
- Standby link
  - Select "Enable Standby Master".
  - The "Standby Connection Name" must match the name of the partner device.
  - You must also configure the standby port.

You will find detailed information in the SCALANCE X-200 configuration manual.

---

### 5.6.1 Electrical connections

#### 5.6.1.1 Electrical attachments to Industrial Ethernet

##### Connection via RJ-45 jacks

The electrical connectors for Industrial Ethernet on the X-200 IE switch are designed as RJ-45 jacks with the following properties:

- MDI-X assignment
- Autonegotiation
- Auto polarity exchange

## MDI / MDI-X autocrossover function

The advantage of this function is that straight-through cables can be used throughout and external Ethernet crossover cables are unnecessary. This prevents malfunctions resulting from mismatching send and receive wires. This makes installation much easier for the user.

---

### Note

#### Formation of loops

Please note that the direct connection of two ports on the switch or accidental connection over several switches causes an illegal loop. Such a loop can lead to network overload and network failures.

---

## Autonegotiation

Autonegotiation means the automatic detection of the functionality of the port at the opposite end. Using autonegotiation, repeaters or end devices can detect the functionality available at the port of a partner device allowing automatic configuration of different types of device. With autonegotiation, two components connected to a link segment can exchange parameters and set themselves to match the supported communication functionality.

---

### Note

- If a port operating in autonegotiation mode is connected to a partner device that is not operating in autonegotiation mode, the partner device must be set permanently to half duplex mode.
  - If a port is set permanently to full duplex, the connected partner device must also be set to full duplex.
  - If the autonegotiation function is disabled, the MDI/MDI-X autocrossover function is also inactive. This means it may be necessary to use a crossover cable.
- 

## Auto polarity exchange

If the pair of receiving cables is incorrectly connected, in other words, RD+ and RD- are swapped over, the polarity is reversed automatically.

### PIN assignment

The following table shows the pin assignment of the RJ-45 connectors:

Pin no.:	Assignment
8	n. c.
7	n. c.
6	TD-
5	n. c.
4	n. c.
3	TD
2	RD-
1	RD+

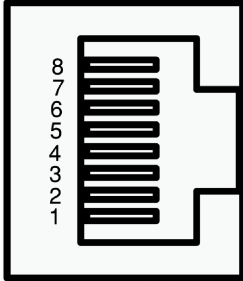

### Permitted cable lengths

- With connection using TP cords or TP-XP cords: maximum 10 m
- When connected using IE FC cable with IE RJ-45 plug:  
Depending on the cable type, a total length of up to 100 m is permitted between two devices.

#### 5.6.1.2 Electrical connectors of the X208PRO

### Connection via M12 sockets

With the IE switch SCALANCE X208PRO, the connection to Industrial Ethernet is via 4-pin, d-coded M12 sockets with MDI-X assignment.

### MDI / MDI-X autocrossover function

The advantage of this function is that straight-through cables can be used throughout and external Ethernet crossover cables are unnecessary. This prevents malfunctions resulting from mismatching send and receive wires. This makes installation much easier for the user.

---

#### Note

##### Formation of loops

Please note that the direct connection of two ports on the switch or accidental connection over several switches causes an illegal loop. Such a loop can lead to network overload and network failures.

---

## PIN assignment

The following table shows the pin assignment of the M12 sockets:

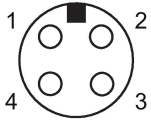
Pin no.:	Assignment	
1	RX+	
2	TX+	
3	RX-	
4	TX-	

## Permitted cable lengths

- With connection using TP cords or TP-XP cords: maximum 10 m
- When connected using IE FC cable with IE RJ-45 plug:  
Depending on the cable type, a total length of up to 100 m is permitted between two devices.

## IE FC M12 plug PRO

The IE FC M12 Plug PRO has a high degree of protection (IP65/67) and is suitable for connecting the X208PRO to Industrial Ethernet. You can obtain this plug using the following order number: 6GK1 901-0DB20-6AA0.

## 5.6.2 Optical attachments to Industrial Ethernet

<p><b>NOTICE</b></p> <p><b>Failure of the data traffic due to contamination of optical plug-in connections</b></p> <p>Optical sockets and plugs are sensitive to contamination of the end face. Contamination can lead to the failure of the optical transmission network.</p> <p>Close unused optical sockets and plugs as well as pluggable transceivers and slots with the supplied protective caps.</p> <p>Remove the protective caps only immediately before you use the plug-in connection.</p>
---

### 5.6.2.1 Multimode fiber-optic cable

#### Transmission medium

The following X-200 IE switches use multimode fiber-optic cables as the transmission medium:

- X204-2
- X204-2TS
- X204-2FM
- X206-1
- X212-2
- XF204-2
- XF206-1
- X202-2IRT

#### Characteristics:

Transmission speed	100 Mbps
Transmission mode	100Base-FX according to IEEE 802.3
Connectors	BFOC sockets
Wavelength	1310 nm
Core diameter	50 or 62.5 µm
Outer diameter	125 µm
Light source	LED
Maximum range (segment length)	5 km



---

**Note**

**No autonegotiation**

With optical transmission, the full duplex mode and transmission speed cannot be changed. For this reason, the autonegotiation function cannot be selected.

---

### 5.6.2.2 Single mode fiber-optic cable

#### Transmission medium

The following X-200 IE switches use single mode fiber-optic cables as the transmission medium:

- X204-2LD
- X204-2LD TS
- X206-1LD
- X212-2LD

#### Characteristics:

Transmission speed	100 Mbps
Transmission mode	100Base-FX according to IEEE 802.3
Connectors	BFOC sockets
Wavelength	1310 nm
Core diameter	9 µm
Outer diameter	125 µm
Light source	LED
Maximum range (segment length)	26 km

---

**Note**

**No autonegotiation**

With optical transmission, the full duplex mode and transmission speed cannot be changed. For this reason, the autonegotiation function cannot be selected.

---

### 5.6.2.3 POF and PCF cables

#### Transmission medium

The following X-200 IE switches use Plastic Optical Fiber (POF) or Polymer Cladded Fiber (PCF) as the transmission medium:

- X200-4P IRT
- X201-3P IRT
- X201-3P IRT PRO
- X202-2P IRT
- X202-2P IRT PRO

#### Characteristics:

Transmission speed	100 Mbps
Transmission mode	100Base-FX analogous to IEEE 802.3
Connectors	SC RJ jacks
Wavelength	650 nm
Core diameter	<ul style="list-style-type: none"> <li>• with POF</li> <li>• with PCF</li> </ul>
Outer diameter	<ul style="list-style-type: none"> <li>• 980 µm</li> <li>• 200 µm</li> </ul>
Light source	LED
Cable lengths	<ul style="list-style-type: none"> <li>• with POF</li> <li>• with PCF</li> </ul>
Signal attenuation	<ul style="list-style-type: none"> <li>• minimum</li> <li>• maximum segment length</li> </ul>
	<ul style="list-style-type: none"> <li>• 0 m</li> <li>• 50 m for POF</li> <li>• 100 m for PCF</li> </ul>
	<ul style="list-style-type: none"> <li>• with POF</li> <li>• with PCF</li> </ul>
	<ul style="list-style-type: none"> <li>• 0.230 dB/m</li> <li>• 0.01 dB/m</li> </ul>

---

#### Note

##### No autonegotiation

With optical transmission, the full duplex mode and transmission speed cannot be changed. For this reason, the autonegotiation function cannot be selected.

---

## GI-PCF

For segment lengths longer than 100 m, you can use GI-PCF cables. Note the information of the manufacturer.

### 5.6.3 Push-pull connector for IRT-PRO devices

#### Push-pull connector technology

With the following devices, the connection to Industrial Ethernet makes use of the PROFINET-compliant push-pull connector technology:

- X204IRT PRO
- X202-2P IRT PRO
- X201-3P IRT PRO

Due to their high degree of protection (IP65), the push-pull connectors are suitable for installation outside cabinets. The plugs do not ship with the product, see the section “Accessories (Page 17)“.



# Approvals

## Approvals issued

---

**Note****Issued approvals on the type plate of the device**

The specified approvals apply only when the corresponding mark is printed on the product. You can check which of the following approvals have been granted for your product by the markings on the type plate.

Approvals for shipbuilding are not printed on the device type plate.

---

## Current approvals on the Internet

You will find the current approvals for the product on the Internet pages of Siemens Industry Online Support.

33118791 (<http://support.automation.siemens.com/WW/view/en/33118791>)

## Approvals for SIMATIC NET products

You will find an overview of the approvals for SIMATIC NET products including approvals for shipbuilding on the Internet pages of Siemens Industry Online Support:

57337426 (<http://support.automation.siemens.com/WW/view/en/57337426>)

## Installation guidelines

The devices meet the requirements if you adhere to the installation and safety instructions contained in this documentation and in the following documentation when installing and operating the devices.

- "Industrial Ethernet / PROFINET Industrial Ethernet" System Manual
- "Industrial Ethernet / PROFINET - Passive network components" System Manual

You will find information on the system manuals in the section "Auto-Hotspot", in "Further documentation".

- "EMC Installation Guidelines" configuration manual

60612658 (<http://support.automation.siemens.com/WW/view/en/60612658>)

 **WARNING**

**Personal injury and property damage can occur**

The installation of expansions that are not approved for SIMATIC NET products or their target systems may violate the requirements and regulations for safety and electromagnetic compatibility.

Only use expansions that are approved for the system.

---

**Note**

The test was performed with a device and a connected communications partner that also meets the requirements of the standards listed above.

When operating the device with a communications partner that does not comply with these standards, adherence to the corresponding values cannot be guaranteed.

---

## EC declaration of conformity

The SIMATIC NET products described in these operating instructions meet the requirements and safety objectives of the following EC directives and comply with the harmonized European standards (EN) for programmable logic controllers which are published in the official documentation of the European Union.

- **2014/34/EU (ATEX explosion protection directive)**

Directive of the European Parliament and the Council of 26 February 2014 on the approximation of the laws of the member states concerning equipment and protective systems intended for use in potentially explosive atmospheres, official journal of the EU L96, 29/03/2014, pages. 309-356

- **2014/30/EU (EMC)**

EMC directive of the European Parliament and of the Council of February 26, 2014 on the approximation of the laws of the member states relating to electromagnetic compatibility; official journal of the EU L96, 29/03/2014, pages. 79-106

- **2011/65/EU (RoHS)**

Directive of the European Parliament and of the Council of 8 June 2011 on the restriction of the use of certain hazardous substances in electrical and electronic equipment

You will find the EC declaration of conformity for these products on the Internet pages of Siemens Industry Online Support

(<http://support.automation.siemens.com/WW/view/en/33118389/134200>).

The EC Declaration of Conformity is available for all responsible authorities at:

Siemens Aktiengesellschaft

Division Process Industries and Drives

Process Automation

DE-76181 Karlsruhe

Germany

## EC directives

SIMATIC NET products meet the requirements and aims of the following EC directives.

### EMC directive (electromagnetic compatibility)

The SIMATIC NET products described in these operating instructions meet the requirements of EC directive 2004/108/EC "Electromagnetic Compatibility" for the following areas of application:

Field of application	Requirements	
	Emission	Immunity to interference
Industry	EN 61000-6-4 : 2007	EN 61000-6-2 : 2005

### Explosion protection directive (ATEX)

The product meets the requirements of the EC directive 94/9/EC "Equipment and Protective Devices for Use in Potentially Explosive Atmospheres".

You will find the current versions of the standards in the currently valid ATEX certificates.

#### II 3 G Ex nA IICT4 Gc

The IE switches SCALANCE X-200 meet the requirements according to II 3 G Ex nA IIC T4 Gc, certificate no.: KEMA 07ATEX0145 X:

<ul style="list-style-type: none"> <li>• X204-2</li> <li>• X204-2TS</li> <li>• X204-2FM</li> <li>• X204-2LD</li> <li>• X204-2LD TS</li> <li>• X206-1</li> <li>• X206-1LD</li> <li>• X208</li> <li>• X208PRO</li> <li>• X212-2</li> <li>• X212-2LD</li> <li>• X216</li> <li>• X224</li> </ul>	<ul style="list-style-type: none"> <li>• XF204</li> <li>• XF204-2</li> <li>• XF206-1</li> <li>• XF208</li> <li>• X200-4P IRT</li> <li>• X201-3P IRT</li> <li>• X201-3P IRT PRO</li> <li>• X202-2IRT</li> <li>• X202-2P IRT</li> <li>• X202-2P IRT PRO</li> <li>• X204IRT</li> <li>• X204IRT PRO</li> <li>• XF204IRT</li> </ul>
--	--

These products meet the requirements of the following standards:

- EN 60079-15
- EN 60079-0

**II 3 (2) G Ex nA [op is] IIC T4**

The IE switches SCALANCE X-200 listed below have additional approval according to II 3 (2) G Ex nA [op is] IIC T4, certificate no.: DEKRA11ATEX0060 X:

<ul style="list-style-type: none"> <li>• X204-2</li> <li>• X204-2TS</li> <li>• X204-2FM</li> <li>• X206-1</li> </ul>	<ul style="list-style-type: none"> <li>• X212-2</li> <li>• XF204-2</li> <li>• XF206-1</li> <li>• X202-2IRT</li> </ul>
--	---

These products meet the requirements of the following standards:

- EN 60079-0
- EN 60079-15
- EN 60079-28

**IECEX**

The SIMATIC NET products meet the requirements of explosion protection according to IECEX.

IECEX classification:

Ex nA IIC T4 Gc

DEK 14.0025X

The products meet the requirements of the following standards:

- IEC 60079-15 (Explosive atmospheres - Part 15: Equipment protection by type of protection "n")
- IEC 60079-0 (Explosive atmospheres - Part 0: Equipment - General requirements)

You will find the current versions of the standards in the currently valid IECEX certificates.

The following SCALANCE X-200 IE switches meet these requirements:

<ul style="list-style-type: none"> <li>• X204-2</li> <li>• X204-2TS</li> <li>• X204-2FM</li> <li>• X204-2LD</li> <li>• X204-2LD TS</li> <li>• X206-1</li> <li>• X206-1LD</li> <li>• X208</li> <li>• X208PRO</li> <li>• X212-2</li> <li>• X212-2LD</li> <li>• X216</li> <li>• X224</li> </ul>	<ul style="list-style-type: none"> <li>• XF204</li> <li>• XF204-2</li> <li>• XF206-1</li> <li>• XF208</li> <li>• X200-4P IRT</li> <li>• X201-3P IRT</li> <li>• X201-3P IRT PRO</li> <li>• X202-2IRT</li> <li>• X202-2P IRT</li> <li>• X202-2P IRT PRO</li> <li>• X204IRT</li> <li>• X204IRT PRO</li> <li>• XF204IRT</li> </ul>
--	--



## IECEx (optical radiation)

The SIMATIC NET products meet the requirements of explosion protection according to IECEx.

IECEx classification:

Ex nA [op is Gb] IIC T4 Gc

DEK 14.0026X

The products meet the requirements of the following standards:

- IEC 60079-15 (Explosive atmospheres - Part 15: Equipment protection by type of protection "n")
- IEC 60079-0 (Explosive atmospheres - Part 0: Equipment - General requirements)
- IEC 60079-28 (Explosive atmospheres - Part 28: Protection of equipment and transmission systems using with optical radiation)

You will find the current versions of the standards in the currently valid IECEx certificates.

The following SCALANCE X-200 IE switches also meet these requirements:

<ul style="list-style-type: none"> <li>• X204-2</li> <li>• X204-2TS</li> <li>• X204-2FM</li> <li>• X206-1</li> <li>• X212-2</li> </ul>	<ul style="list-style-type: none"> <li>• XF204-2</li> <li>• XF206-1</li> <li>• X202-2IRT</li> </ul>
--	---

## FM

The product meets the requirements of the standards:

- Factory Mutual Approval Standard Class Number 3611
- FM Hazardous (Classified) Location Electrical Equipment:  
Non Incendive / Class I / Division 2 / Groups A,B,C,D / T4 and  
Non Incendive / Class I / Zone 2 / Group IIC / T4

## cULus approval for industrial control equipment

cULus Listed IND. CONT. EQ.

Underwriters Laboratories Inc. complying with

- UL 508
- CSA C22.2 No. 142-M1987

Report no. E85972

### **cULus Approval for Information Technology Equipment**

cULus Listed I. T. E.

Underwriters Laboratories Inc. complying with

- UL 60950-1 (Information Technology Equipment)
- CSA C22.2 No. 60950-1-03

Report no. E115352

### **cULus Approval Hazardous Location**

cULus Listed I. T. E. FOR HAZ. LOC.

Underwriters Laboratories Inc. complying with

- UL 60950-1 (Information Technology Equipment)
- ANSI/ISA 12.12.01-2007
- CSA C22.2 No. 213-M1987

Approved for use in

Cl. 1, Div. 2, GP A, B, C, D T4

Cl. 1, Zone 2, GP IIC T4

Report no. E240480

### **CSA Approval for Information Technology Equipment**

CSA Certification Mark

Canadian Standard Association CSA C22.2 No. 60950-1-03

### **CSA Approval for Industrial Control Equipment**

CSA Certification Mark

Canadian Standard Association CSA C22.2 No. 142-1987

## FDA and IEC approvals

The following SCALANCE X-200 switches meet the FDA and IEC requirements listed below:

- X204-2LD
- X204-2LD TS
- X206-1LD
- X212-2LD



Image 6-1 FDA and IEC approvals

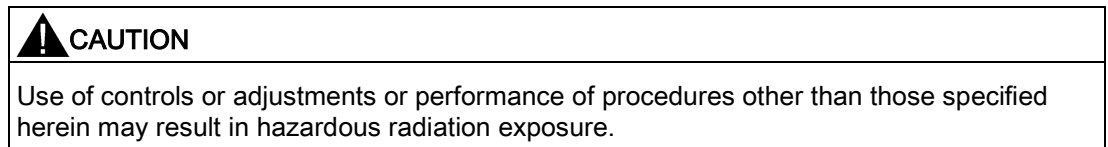

## RCM

The product meets the requirements of the AS/NZS 2064 standard (Class A).

## MSIP 요구사항 - For Korea only

### A급 기기(업무용 방송통신기자재)

이 기기는 업무용(A급) 전자파 적합기기로서 판매자 또는 사용자는 이 점을 주의하시기 바라며, 가정 외의 지역에서 사용하는 것을 목적으로 합니다.

## Marking for the customs union



EAC (Eurasian Conformity)

Customs union of Russia, Belarus and Kazakhstan

Declaration of the conformity according to the technical regulations of the customs union (TR CU)

## Railway approval

The TS variant of the device meets the requirements of the Railway standard EN 50155:2007 "Railway Applications - Electronic equipment used on rolling stock".



# Technical specifications

## Construction

Type	Dimensions (W x H x D) in mm	Weight in g	Installation options - DIN rail - S7-300 standard rail - Wall mounting
X204-2	60 x 125 x 124	780	+
X204-2TS	60 x 125 x 124	780	+
X204-2FM	60 x 125 x 124	780	+
X204-2LD	60 x 125 x 124	780	+
X204-2LD TS	60 x 125 x 124	780	+
X206-1	60 x 125 x 124	780	+
X206-1LD	60 x 125 x 124	780	+
X208	60 x 125 x 124	780	+
X208PRO	90 x 125 x 124	1000	+
X212-2	120 x 125 x 124	1200	+
X212-2LD	120 x 125 x 124	1200	+
X216	120 x 125 x 124	1200	+
X224	180 x 125 x 124	1600	+
XF204	75 x 125 x 73	250	DIN rail mounting only.
XF204-2	75 x 125 x 73	250	DIN rail mounting only.
XF206-1	75 x 125 x 73	250	DIN rail mounting only.
XF208	75 x 125 x 73	250	DIN rail mounting only.
X200-4P IRT	60 x 125 x 124	780	+
X201-3P IRT	60 x 125 x 124	780	+
X201-3P IRT PRO	90 x 125 x 124	1000	+
X202-2IRT	60 x 125 x 124	780	+
X202-2P IRT	60 x 125 x 124	780	+
X202-2P IRT PRO	90 x 125 x 124	1000	+
X204IRT	60 x 125 x 124	780	+
X204IRT PRO	90 x 125 x 124	1000	+
XF204IRT	75 x 125 x 73	250	DIN rail mounting only.

Ports

Type	Connectors for end devices or network components via twisted pair RJ-45 jacks with MDI X pinning 10/100 Mbps (half / full duplex) <sup>1)</sup>	Connections for end devices or network components via FO cable BFOC sockets (100 Mbps, full duplex to 100BaseFX)	Connectors for power supply 4-pin plug-in terminal block, redundant <sup>2)</sup>	Connectors for signaling contact 2-pin plug-in terminal block <sup>3)</sup>
X204-2	4	2	1	1
X204-2TS	4	2	1	1
X204-2FM	4	2	1	1
X204-2LD	4	2	1	1
X204-2LD TS	4	2	1	1
X206-1	6	1	1	1
X206-1LD	6	1	1	1
X208	8	-	1	1
X208PRO	8 <sup>1)</sup>	-	1 <sup>2)</sup>	1 <sup>3)</sup>
X212-2	12	2	1	1
X212-2LD	12	2	1	1
X216	16	-	1	1
X224	24	-	1	1
XF204	4	-	1	1
XF204-2	4	2	1	1
XF206-1	6	1	1	1
XF208	8	-	1	1
X202-2IRT	2	2	1	1
X204IRT	4	-	1	1
XF204IRT	4	-	1	1

1) Exception X208PRO: Connection via 4-pin, d-coded M12 socket, IP65/67.

2) Exception X208PRO: Connection via 4-pin, a-coded M12 socket, IP65/67.

3) Exception X208PRO: Connection via 5-pin, b-coded M12 socket, IP65/67.

Type	Connectors for end devices or network components via twisted pair RJ-45 jacks with MDI X pinning 10/100 Mbps (half / full duplex)	Connections for end devices or network components via FO cable SC RJ jacks (push-pull) (100 Mbps, full duplex to 100BaseFX)	Connector for power supply 4-pin plug-in terminal block, redundant	Connector for signaling contact 2-pin plug-in terminal block
X200-4P IRT	-	4	1	1
X201-3P IRT	1	3	1	1
X202-2P IRT	2	2	1	1

Type	Connectors for end devices or network components via twisted pair RJ-45 jacks with MDI X pinning 10/100 Mbps half / full duplex	Connections for end devices or network components via FO cable SC RJ jacks (push-pull), 100 Mbps, full duplex to 100BaseFX	Connector for power supply 5-pin Power Plug PRO connector (male)	Connector for signaling contact 5-pin b-coded M12 connector (male)
X201-3P IRT PRO	1	3	2	1
X202-2P IRT PRO	2	2	2	1
X204IRT PRO	4	-	2	1

## Signaling contact

The following applies to all devices:

- Voltage for the signaling contact: 24 VDC
- Current through the signaling contact: maximum 100 mA

## Electrical data

Type	Supply voltage with redundant connection Rated voltage 12 to 24 VDC SELV Voltage range 10 VDC to 28.8 VDC Permitted voltage range incl. total ripple 10 VDC to 30.2 VDC	Power loss at 12 VDC	Current consumption at rated voltage	Overcurrent protection at input Non-replaceable fuse (F)
X204-2TS	+	6.60 W	600 mA	3.0 A / 32 V
X204-2LD TS	+	6.60 W	600 mA	3.0 A / 32 V

Type	Supply voltage with redundant connection Rated voltage 24 VDC Voltage range 19.2 VDC to 28.8 VDC Permitted voltage range incl. total ripple 18.5 VDC to 30.2 VDC	Power loss at 24 VDC	Current consumption at rated voltage	Overcurrent protection at input PTC resettable fuse
X204-2	+	6.36 W	265 mA	600 mA / 60 V
X204-2FM	+	6.36 W	265 mA	600 mA / 60 V
X204-2LD	+	6.36 W	265 mA	600 mA / 60 V
X206-1	+	5.28 W	220 mA	600 mA / 60 V
X206-1LD	+	5.28 W	220 mA	600 mA / 60 V
X208	+	3.84 W	185 mA	600 mA / 60 V
X208PRO	+	4.4 W	185 mA	600 mA / 60 V
X212-2	+	7.92 W	330 mA	1.1 A / 33 V
X212-2LD	+	7.92 W	330 mA	1.1 A / 33 V
X216	+	5.76 W	240 mA	1.1 A / 33 V

Type	Supply voltage with redundant connection Rated voltage 24 VDC Voltage range 19.2 VDC to 28.8 VDC Permitted voltage range incl. total ripple 18.5 VDC to 30.2 VDC	Power loss at 24 VDC	Current consumption at rated voltage	Overcurrent protection at input PTC resettable fuse
X224	+	8.40 W	350 mA	1.1 A / 33 V
XF204	+	2.64 W	110 mA	1.1 A / 33 V
XF204-2	+	5.28 W	220 mA	1.1 A / 33 V
XF206-1	+	4.08 W	170 mA	1.1 A / 33 V
XF208	+	3.12 W	130 mA	1.1 A / 33 V
X200-4P IRT	+	9.6 W	400 mA	1.1 A / 33 V
X201-3P IRT	+	8.4 W	350 mA	1.1 A / 33 V
X201-3P IRT PRO	no redundancy	7.2 W	300 mA	1.1 A / 33 V
X202-2IRT	+	6.0 W	300 mA	600 mA / 60 V
X202-2P IRT	+	7.2 W	300 mA	1.1 A / 33 V
X202-2P IRT PRO	no redundancy	7.2 W	300 mA	1.1 A / 33 V
X204IRT	+	4.8 W	200 mA	600 mA / 60 V
X204IRT PRO	no redundancy	4.8 W	200 mA	600 mA / 60 V
XF204IRT	+	4.8 W	200 mA	600 mA / 60 V

### Optical data

Type	Transmitter output (optical)		Receiver input	
	min. [dBm]	max. [dBm]	Sensitivity min. [dBm]	Input power max. [dBm]
X204-2 X204-2TS X204-2FM X206-1 X212-2 XF204-2 XF206-1 X202-2IRT	-19	-14	-32	-3
X204-2LD X204-2LD TS X206-1LD X212-2LD	-15	-8	-34	-3
X200-4P IRT X201-3P IRT X201-3P IRT PRO X202-2P IRT X202-2P IRT PRO	-8	-2	-23	+1



## Permitted cable lengths - copper

### For devices with degree of protection IP20/30

The following cables are permitted in the specified lengths:

- **0 to 55 m:**

IE TP torsion cable with IE FC RJ-45 Plug 180

– Alternative:

0 to 45 m IE TP Torsion Cable + 10 m TP Cord via IE Outlet RJ-45

- **0 to 85 m:**

IE FC TP marine / trailing / flexible / FRNC / festoon / food cable with IE FC RJ-45 Plug 180

– Alternative:

0 to 75 m IE FC TP marine / trailing / flexible / FRNC / festoon / food cable + 10 m TP cord over IE FC outlet RJ-45

- **0 to 100 m:**

IE FC TP standard cable with IE FC RJ-45 plug 180

– Alternative:

0 to 90 m IE FC TP standard cable + 10 m TP cord via IE FC outlet RJ-45

### For devices with the "PRO" supplement (degree of protection IP65)

With these devices, splitting of the cables (as above) is not permitted. The following cables are permitted in the specified lengths:

- **0 to 55 m:**

IE TP torsion cable with IE FC RJ-45 Plug 180

- **0 to 85 m:**

IE FC TP marine / trailing / flexible / FRNC / festoon / food cable with IE FC RJ-45 Plug 180

- **0 to 100 m:**

IE FC TP standard cable with IE FC RJ-45 plug 180

**For X208PRO (degree of protection IP65/67)**

Also with the X208PRO, splitting of the cables (as above) is not permitted. The following cables are permitted in the specified lengths:

- **0 to 55 m:**  
IE TP torsion cable with IE FC M12 Plug PRO
- **0 to 85 m:**  
IE FC TP marine / trailing / flexible / FRNC / festoon / food cable with IE FC M12 Plug PRO
- **0 to 100 m:**  
IE FC TP standard cable with IE FC M12 plug PRO

**Permitted cable lengths - fiber-optic**

Type	1 - 50 m 980/1000 plastic optical fiber (POF)	1 - 100 m 200/230 polymer clad fiber (PCF) 6 dB max. permitted cable attenuation with 3 dB link power margin	0 - 4000 Glass FO cable 62.5/125 µm glass fibers 0 - 5000 Glass FO cable 50/125 µm glass fibers  ≤ 1 dB/km at 1300 nm; 600 MHz x km; 6 dB max. permitted cable attenuation with 3 dB link power margin	0 - 26000 m glass FO cable 9/125 µm single mode fiber; 0.5 dB/km at 1300 nm; 13 dB max. permitted cable attenuation with 2 dB link power margin
X204-2	-	-	+	-
X204-2TS	-	-	+	-
X204-2FM	-	-	+	-
X204-2LD	-	-	-	+
X204-2LD TS	-	-	-	+
X206-1	-	-	+	-
X206-1LD	-	-	-	+
X212-2	-	-	+	-
X212-2LD	-	-	-	+
XF204-2	-	-	+	-
XF206-1	-	-	+	-
X200-4P IRT	+	+	-	-
X201-3P IRT	+	+	-	-
X201-3P IRT PRO	+	+	-	-
X202-2IRT	-	-	+	-
X202-2P IRT	+	+	-	-
X202-2P IRT PRO	+	+	-	-

## Degree of protection and MTBF

Type	Degree of protection	MTBF
X204-2	IP30	64 years
X204-2TS	IP20	63 years
X204-2FM	IP30	87 years
X204-2LD	IP30	60 years
X204-2LD TS	IP20	85 years
X206-1	IP30	72 years
X206-1LD	IP30	69 years
X208	IP30	83 years
X208PRO	IP65/67	83 years
X212-2	IP30	46 years
X212-2LD	IP30	43 years
X216	IP30	52 years
X224	IP30	45 years
XF204	IP20	48 years
XF204-2	IP20	60 years
XF206-1	IP20	69 years
XF208	IP20	54 years
X200-4P IRT	IP30	73 years
X201-3P IRT	IP30	78 years
X201-3P IRT PRO	IP65	85 years
X202-2IRT	IP30	62 years
X202-2P IRT	IP30	84 years
X202-2P IRT PRO	IP65	85 years
X204IRT	IP30	81 years
X204IRT PRO	IP65	99 years
XF204IRT	IP20	81 years

## Switching properties

Type	Max. number of learnable addresses	Aging time	Switching technique	Latency
X-200	8000	30 s	Store and forward	5 $\mu$ s
XF-200	8000	30 s	Store and forward	5 $\mu$ s
X-200IRT	4096	30 s (configurable)	Store and forward / cut through	< 5 $\mu$ s
XF204IRT	4096	30 s (configurable)	Store and forward / cut through	< 5 $\mu$ s

## Permitted ambient conditions

### Note

#### Note the mounting position for XF and TS devices

With the following switches an ambient temperature of maximum +40 °C is permitted if the device is installed on a vertical rail:

- XF204
- XF208
- XF204-2
- XF206-1
- XF204IRT
- X204-2TS
- X204-2LD TS

Type	Operating temperature	Storage/transport temperature	Rel. humidity in operation (no condensation)	Operating altitude at max. xx °C ambient temperature
X204-2	-40 °C to +60 °C	-40 °C to +70 °C	< 95 %	2000 m at max. 56 °C 3000 m at max. 50 °C
X204-2TS	-40 °C to +70 °C *)	-40 °C to +70 °C	< 95 %	2000 m at max. 56 °C 3000 m at max. 50 °C
X204-2FM	-40 °C to +60 °C	-40 °C to +70 °C	< 95 %	2000 m at max. 56 °C 3000 m at max. 50 °C
X204-2LD	-40 °C to +60 °C	-40 °C to +70 °C	< 95 %	2000 m at max. 56 °C 3000 m at max. 50 °C
X204-2LD TS	-40 °C to +70 °C *)	-40 °C to +70 °C	< 95 %	2000 m at max. 56 °C 3000 m at max. 50 °C
X206-1	-40 °C to +60 °C	-40 °C to +70 °C	< 95 %	2000 m at max. 56 °C 3000 m at max. 50 °C
X206-1LD	-40 °C to +60 °C	-40 °C to +70 °C	< 95 %	2000 m at max. 56 °C 3000 m at max. 50 °C
X208	-40 °C to +60 °C	-40 °C to +70 °C	< 95 %	2000 m at max. 56 °C 3000 m at max. 50 °C
X208PRO	-40 °C to +70 °C	-40 °C to +70 °C	< 95 %	2000 m at max. 56 °C 3000 m at max. 50 °C
X212-2	-40 °C to +60 °C	-40 °C to +70 °C	< 95 %	2000 m at max. 56 °C 3000 m at max. 50 °C
X212-2LD	-40 °C to +60 °C	-40 °C to +70 °C	< 95 %	2000 m at max. 56 °C 3000 m at max. 50 °C
X216	-40 °C to +60 °C	-40 °C to +70 °C	< 95 %	2000 m at max. 56 °C 3000 m at max. 50 °C
X224	-40 °C to +60 °C	-40 °C to +70 °C	< 95 %	2000 m at max. 56 °C 3000 m at max. 50 °C
XF204 *)	-40 °C to +60 °C	-40 °C to +70 °C	< 95 %	2000 m at max. 56 °C 3000 m at max. 50 °C
XF204-2	-40 °C to +60 °C *)	-40 °C to +70 °C	< 95 %	2000 m at max. 56 °C 3000 m at max. 50 °C
XF206-1	-40 °C to +60 °C *)	-40 °C to +70 °C	< 95 %	2000 m at max. 56 °C 3000 m at max. 50 °C

Type	Operating temperature	Storage/transport temperature	Rel. humidity in operation (no condensation)	Operating altitude at max. xx °C ambient temperature
XF208	-40 °C to +60 °C *)	-40 °C to +70 °C	< 95 %	2000 m at max. 56 °C 3000 m at max. 50 °C
X200-4P IRT	-25 °C to +40 °C	-40 °C to +70 °C	< 95 %	2000 m at max. 35 °C 3000 m at max. 30 °C
X201-3P IRT	-25 °C to +50 °C	-40 °C to +70 °C	< 95 %	2000 m at max. 45 °C 3000 m at max. 40 °C
X201-3P IRT PRO	-25 °C to +60 °C	-40 °C to +70 °C	< 95 %	2000 m at max. 56 °C 3000 m at max. 50 °C
X202-2IRT	-40 °C to +60 °C	-40 °C to +70 °C	< 95 %	2000 m at max. 56 °C 3000 m at max. 50 °C
X202-2P IRT	-25 °C to +60 °C	-40 °C to +70 °C	< 95 %	2000 m at max. 56 °C 3000 m at max. 50 °C
X202-2P IRT PRO	-25 °C to +60 °C	-40 °C to +70 °C	< 95 %	2000 m at max. 56 °C 3000 m at max. 50 °C
X204IRT	-40 °C to +70 °C	-40 °C to +70 °C	< 95 %	2000 m at max. 56 °C 3000 m at max. 50 °C
X204IRT PRO	-25 °C to +70 °C	-40 °C to +70 °C	< 95 %	2000 m at max. 56 °C 3000 m at max. 50 °C
XF204IRT	-40 °C to +60 °C *)	-40 °C to +70 °C	< 95 %	2000 m at max. 56 °C 3000 m at max. 50 °C

\*) Note the information on the mounting position above.

## Frame delay times

The number of IE Switches X-200 connected in a line influences the frame delay.

---

### Note

#### Frame delay time with X-200 without IRT

When a frame passes through X-200 IE switches, it is delayed by the Store&Forward function of the X-200 IE switches.

- With a 64 byte frame length by approx. 10 microseconds (at 100 Mbps).
- With a 1500 byte frame length by approx. 130 microseconds (at 100 Mbps).

This means that the more X-200 IE switches the frame passes through, the longer the frame delay.

---

### Note

#### Frame delay time with X-200 with IRT

The more X-200IRT IE switches a frame runs through, the higher the frame delay. By using the "cut through" switching mechanism, the X-200IRT IE switches are ideal to meet the real-time requirements of PROFINET.

Cut through is, however, not possible:

- Between a port set to 10 Mbps and a port set to 100 Mbps.
- When two packets are to be sent at the same time on one port.

In this case, an X-200 IE switch changes to Store&Forward and the delay increases.

---



# Dimension drawings

# A

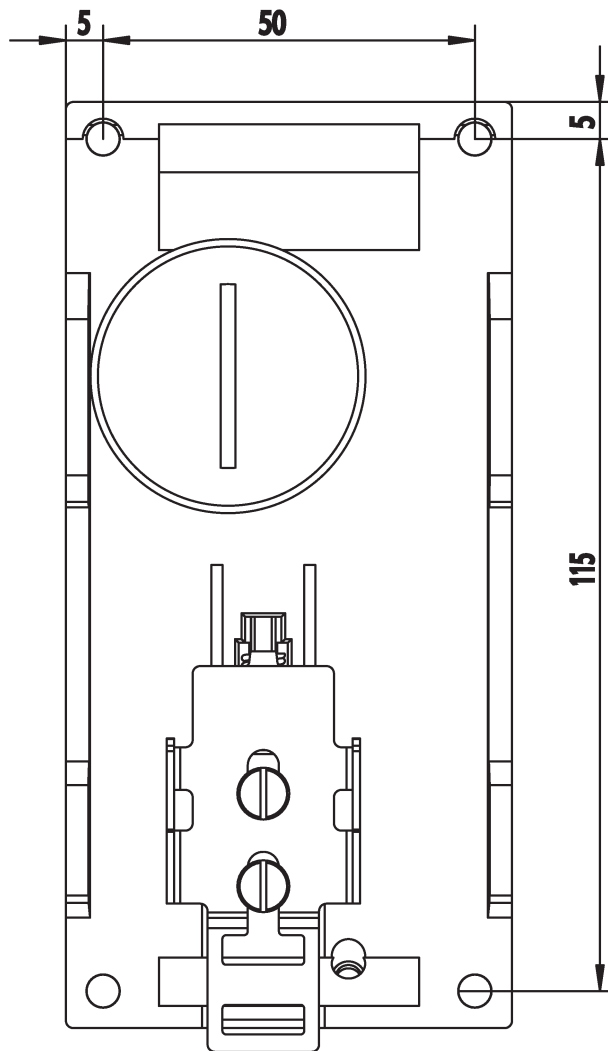

Image A-1 Drilling pattern SCALANCE X204-2, X204-2TS, X204-2FM, X204-2LD, X204-2LD TS, X206-1, X206-1LD, X208, X200-4P IRT, X201-3P IRT, X202-2IRT, X202-2P IRT, X204IRT

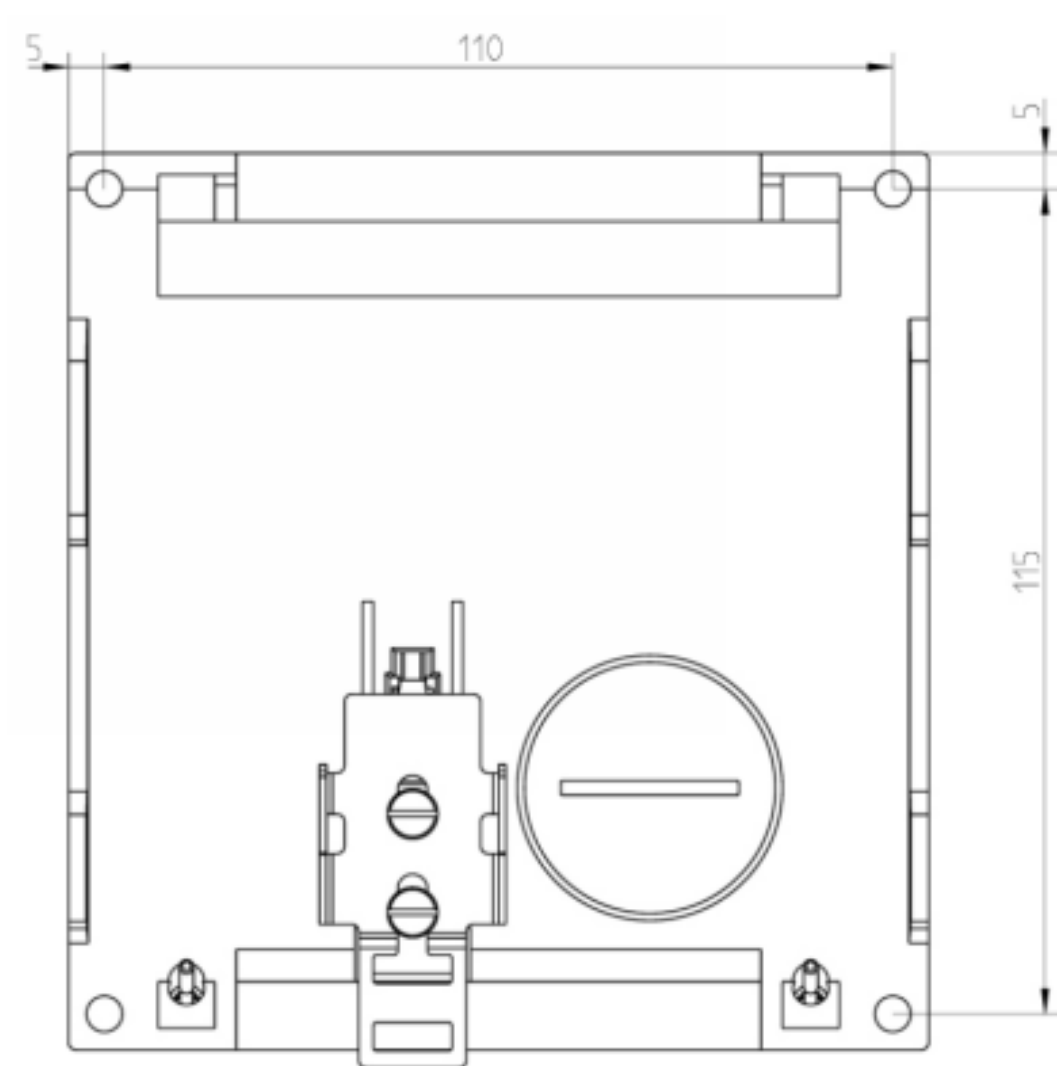

Image A-2 Drilling pattern SCALANCE X212-2, X212-2LD and X216



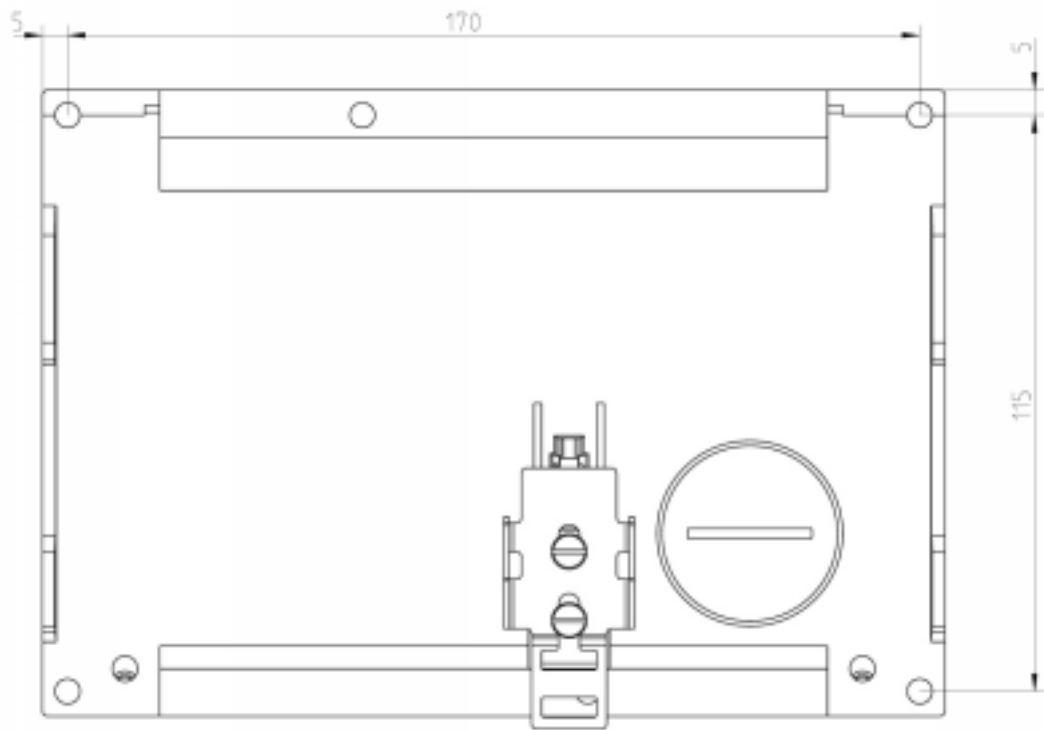

Image A-3 Drilling pattern SCALANCE X224

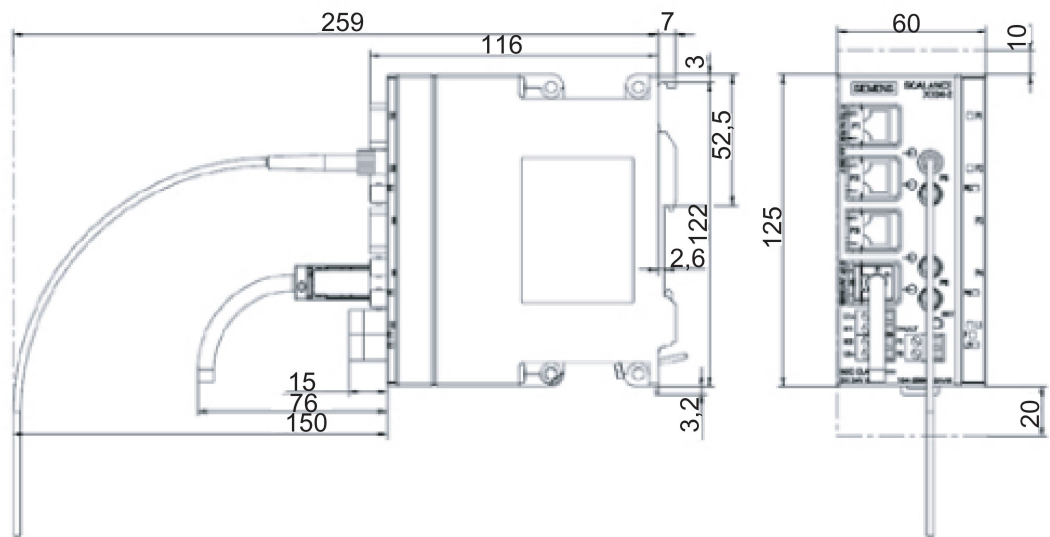

Image A-4 Side view SCALANCE X-200

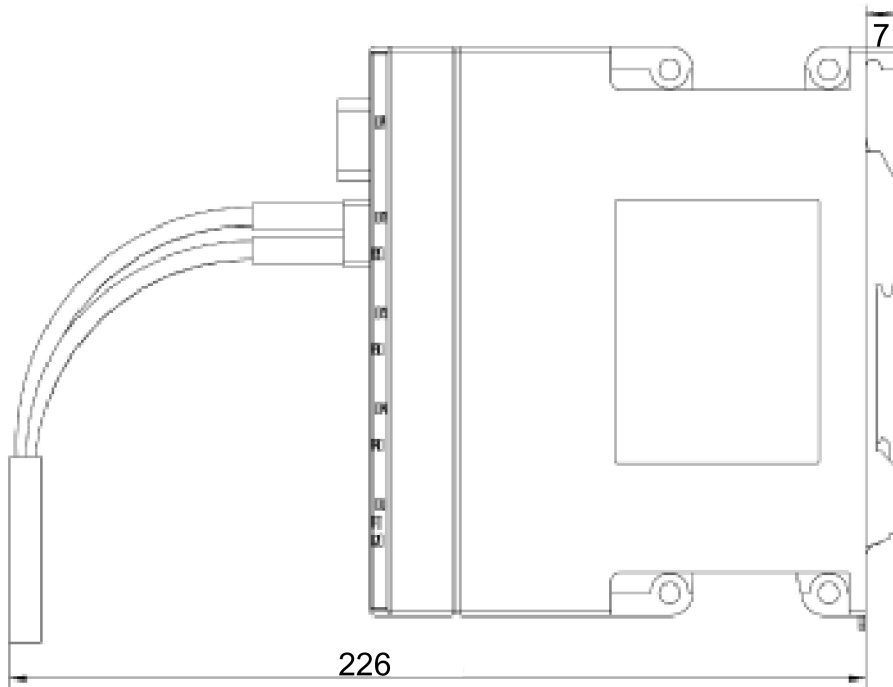

Image A-5 Side view SCALANCE X-200 POF with POF interface

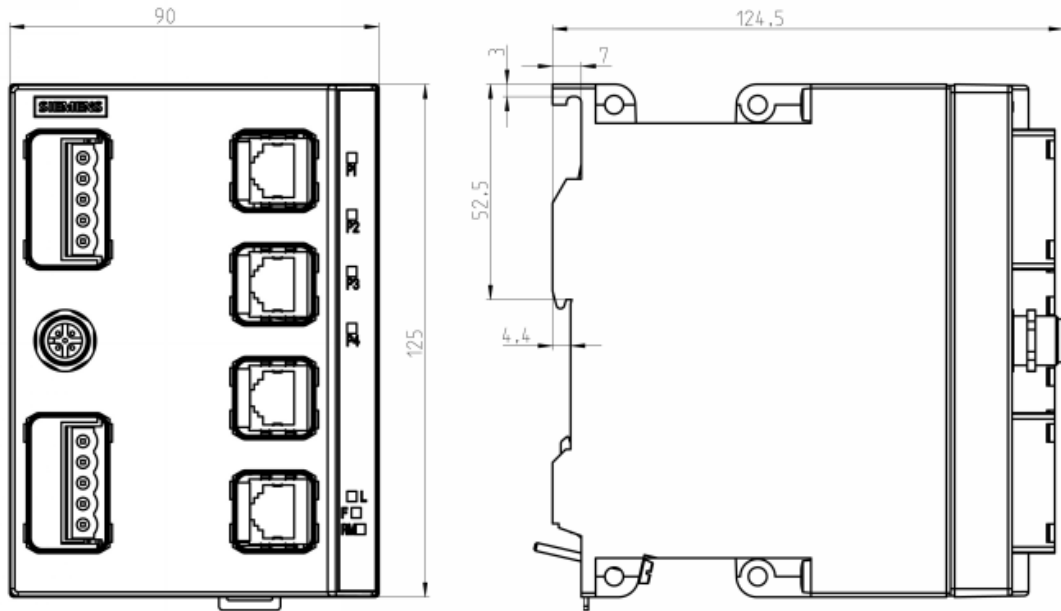

Image A-6 Dimension drawings of the SCALANCE X208PRO, SCALANCE X201-3P IRT PRO, SCALANCE X202-2P IRT PRO and SCALANCE X204IRT PRO

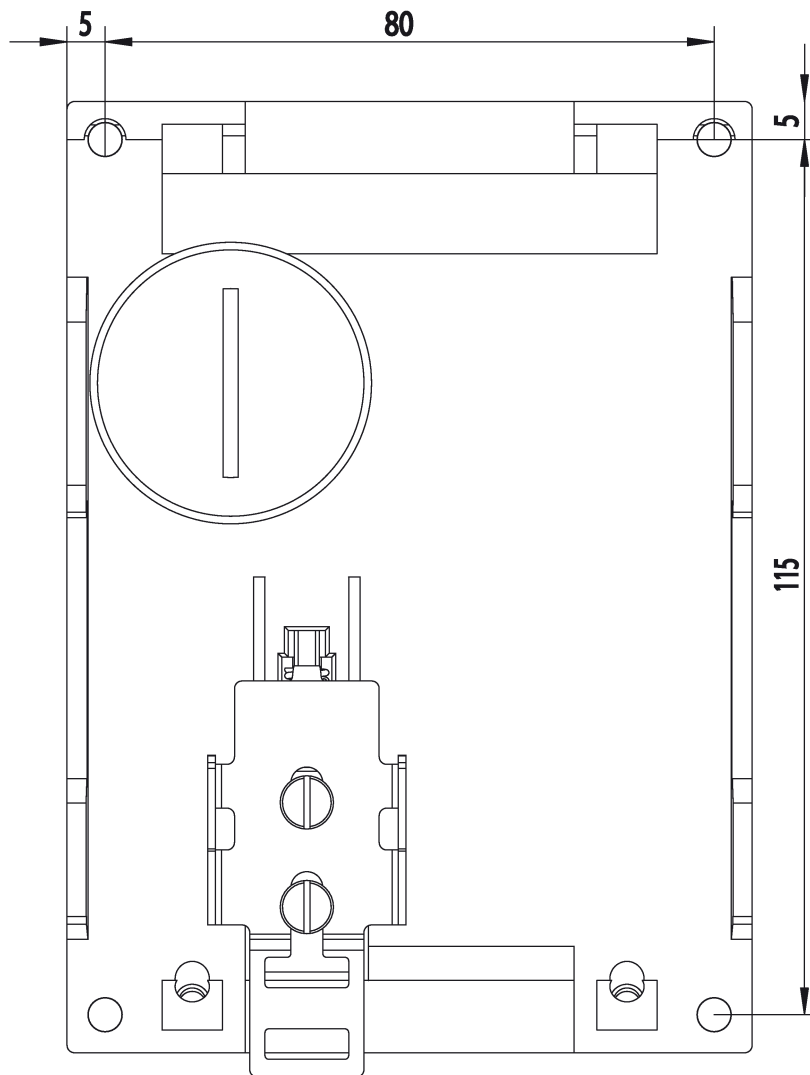

Image A-7 Drilling pattern of the SCALANCE X208PRO, SCALANCE X201-3P IRT PRO, SCALANCE X202-2P IRT PRO and SCALANCE X204IRT PRO

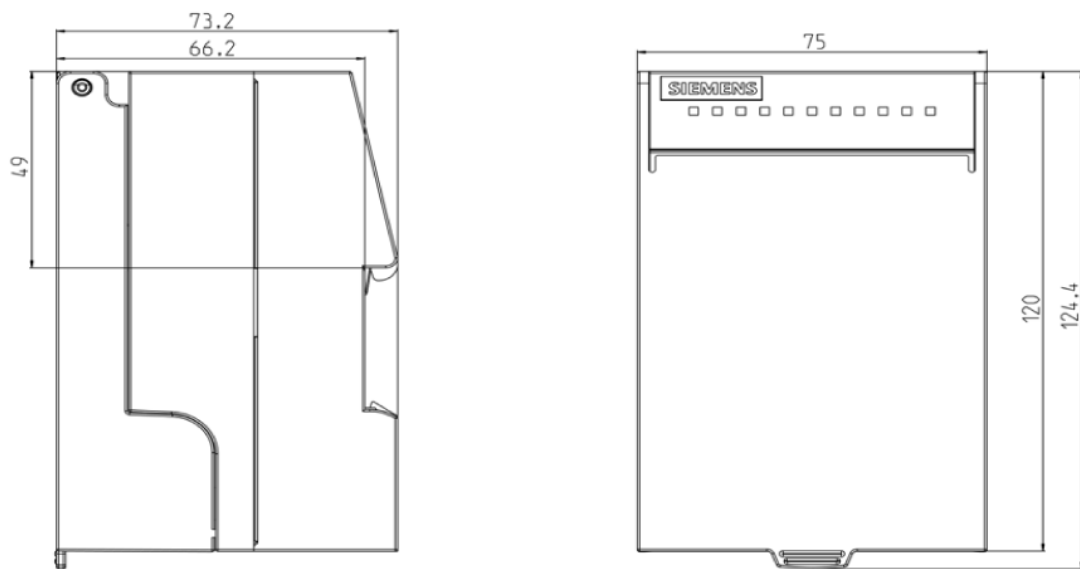

Image A-8 SCALANCE XF-200 dimension drawings

## Test of mechanical stability

### Mechanical stability

Device type SCALANCE	IEC 60068-2-6 vibration		IEC 60068-2-27 shock	
X204-2	5 – 9 Hz: 3.5 mm 9 – 500 Hz: 1 g 1 octave/min, 20 sweeps		15 g, 6 ms duration 6 shocks per axis	
X204-2TS	5 – 9 Hz: 3.5 mm 9 – 500 Hz: 1 g 1 octave/min, 20 sweeps	5 – 150 Hz: Max. 7.9 g random	15 g, 6 ms duration 6 shocks per axis	50 g, 30 ms duration 6 shocks per axis
X204-2FM	5 – 9 Hz: 3.5 mm 9 – 500 Hz: 1 g 1 octave/min, 20 sweeps		15 g, 6 ms duration 6 shocks per axis	
X204-2LD	5 – 9 Hz: 3.5 mm 9 – 500 Hz: 1 g 1 octave/min, 20 sweeps		15 g, 11 ms duration 6 shocks per axis	
X204-2LD TS	5 – 9 Hz: 3.5 mm 9 – 500 Hz: 1 g 1 octave/min, 20 sweeps	5 – 150 Hz: Max. 7.9 g random	15 g, 6 ms duration 6 shocks per axis	50 g, 30 ms duration 6 shocks per axis
X206-1	5 – 9 Hz: 3.5 mm 9 – 500 Hz: 1 g 1 octave/min, 20 sweeps		15 g, 6 ms duration 6 shocks per axis	
X206-1 LD	5 – 9 Hz: 3.5 mm 9 – 500 Hz: 1 g 1 octave/min, 20 sweeps		15 g, 6 ms duration 6 shocks per axis	
X208	5 – 9 Hz: 3.5 mm 9 – 500 Hz: 1 g 1 octave/min, 20 sweeps		15 g, 6 ms duration 6 shocks per axis	
X208PRO	5 - 9 Hz 3.5 mm 9 - 150 Hz 1 g 10 cycles		15 g, 11 ms duration 6 shocks/axis	
X212-2	5 – 9 Hz: 3.5 mm 9 – 500 Hz: 1 g 1 octave/min, 20 sweeps		15 g, 11 ms duration 6 shocks per axis	
X212-2LD	5 – 9 Hz: 3.5 mm 9 – 500 Hz: 1 g 1 octave/min, 20 sweeps		15 g, 6 ms duration 6 shocks per axis	
X216	5 – 9 Hz: 3.5 mm 9 – 500 Hz: 1 g 1 octave/min, 20 sweeps		15 g, 11 ms duration 6 shocks per axis	
X224	5 – 9 Hz: 3.5 mm 9 – 500 Hz: 1 g 1 octave/min, 20 sweeps		15 g, 11 ms duration 6 shocks per axis	
XF204	5 – 9 Hz: 3.5 mm 9 – 500 Hz: 1 g 1 octave/min, 20 sweeps		15 g, 6 ms duration 6 shocks per axis	
XF204-2	5 – 9 Hz: 3.5 mm 9 – 500 Hz: 1 g 1 octave/min, 20 sweeps		15 g, 6 ms duration 6 shocks per axis	

Device type SCALANCE	IEC 60068-2-6 vibration	IEC 60068-2-27 shock
XF206-1	5 – 9 Hz: 3.5 mm 9 – 500 Hz: 1 g 1 octave/min, 20 sweeps	15 g, 6 ms duration 6 shocks per axis
XF208	5 – 9 Hz: 3.5 mm 9 – 500 Hz: 1 g 1 octave/min, 20 sweeps	15 g, 6 ms duration 6 shocks per axis
X200-4P IRT	5 – 9 Hz: 3.5 mm 9 – 500 Hz: 1 g 1 octave/min, 20 sweeps	15 g, 11 ms duration 6 shocks per axis
X201-3P IRT	5 – 9 Hz: 3.5 mm 9 – 500 Hz: 1 g 1 octave/min, 20 sweeps	15 g, 11 ms duration 6 shocks per axis
X201-3P IRT PRO	5 – 9 Hz: 3.5 mm 9 – 150 Hz: 1 g 10 cycles per axis	15 g, 11 ms duration 6 shocks per axis
X202-2IRT	10 - 58 Hz: 0.075 mm 58 - 500 Hz: 1 g 10 cycles per axis	10 g, 16 ms duration 6 shocks per axis
X202-2P IRT	5 – 9 Hz: 3.5 mm 9 – 500 Hz: 1 g 1 octave/min, 20 sweeps	15 g, 11 ms duration 6 shocks per axis
X202-2P IRT PRO	5 – 9 Hz: 3.5 mm 9 – 150 Hz: 1 g 10 cycles per axis	15 g, 11 ms duration 6 shocks per axis
X204IRT	10 - 58 Hz: 0.075 mm 58 - 500 Hz: 1 g 10 cycles per axis	10 g, 16 ms duration 6 shocks per axis
X204IRT PRO	5 – 9 Hz: 3.5 mm 9 – 150 Hz: 1 g 10 cycles per axis	15 g, 11 ms duration 6 shocks per axis
XF204IRT	10 - 58 Hz: 0.075 mm 58 - 500 Hz: 1 g 10 cycles per axis	10 g, 16 ms duration 6 shocks per axis

**Note**

The interfaces of the X-200 IE switches can be divided into groups each with 4 ports:

- P1 to P4
- P5 to P8
- P9 to P12
- etc.

If only ports of different port groups are used, the device meets the requirements for Environment B in compliance with IEEE 802.3, Section 33.4.1.1. If ports of the same port group are used, the requirements for Environment A are met.



# Training, Service & Support

## Industry Online Support

In addition to the product documentation, the comprehensive online information platform of Siemens Industry Online Support at the following Internet address:

<http://support.automation.siemens.com/WW/llisapi.dll?func=cslib.csinfo2&aktprim=99&lang=en>

Apart from news, there you will also find:

- Project information: Manuals, FAQs, downloads, application examples etc.
- Contacts, Technical Forum
- The option submitting a support query:

<https://support.automation.siemens.com/WW/llisapi.dll?func=cslib.csinfo&lang=en&objid=38718979&caller=view>

- Our service offer:

Right across our products and systems, we provide numerous services that support you in every phase of the life of your machine or system - from planning and implementation to commissioning, through to maintenance and modernization.

You will find contact data on the Internet at the following address:

<http://www.automation.siemens.com/partner/guiwelcome.asp?lang=en>

## SITRAIN - Training for Industry

The training offer includes more than 300 courses on basic topics, extended knowledge and special knowledge as well as advanced training for individual sectors - available at more than 130 locations. Courses can also be organized individually and held locally at your location.

You will find detailed information on the training curriculum and how to contact our customer consultants at the following Internet address:

[www.siemens.com/sitrain](http://www.siemens.com/sitrain)





# Index

## A

Article number  
  C-PLUG, 17, 17  
  Power Plug PRO, 46  
  Redundancy module, 17  
  RJ-45 data plug-in connector, 17  
  SC RJ plug-in connector, 18  
Auto polarity exchange, 53  
Autonegotiation, 53, 53

## C

Components of the product, 3  
Configuration Manual, 4

## E

ESD directives, 28  
Extension module, 17, 41

## F

Factory settings, 23  
Frame delay times, 12  
Function, 11

## G

GI-PCF, 59  
Glossary, 8

## M

MDI / MDI-X autocrossover, 53, 54

## N

Node localization, 22  
Number of connectors, 13

## O

Operating instructions, 4  
Order number  
  C-PLUG, 25  
Overview of the functions, 13

## P

Polarity reversal, 53  
Power limiter, 17, 41  
Power Plug PRO  
  Article number, 46

## R

Redundancy module, 41

## S

Safety notices  
  Use in hazardous areas, 41  
  when connecting up, 41  
Selection Tool, 6  
SET button, 22  
SIMATIC NET glossary, 8  
SIMATIC NET Selection Tool, 6  
Support, 87  
System manual, 6, 61

## T

Training, 87

