

SIEMENS

SIMATIC NET

Industrial Ethernet switches SCALANCE XP-200

Operating Instructions

Introduction

Safety notices

1

Description of the device

2

Installation

3

Connecting up

4

Upkeep and maintenance

5

Technical specifications

6

Dimension drawings

7



Approvals

A

Legal information

Warning notice system

This manual contains notices you have to observe in order to ensure your personal safety, as well as to prevent damage to property. The notices referring to your personal safety are highlighted in the manual by a safety alert symbol, notices referring only to property damage have no safety alert symbol. These notices shown below are graded according to the degree of danger.

 DANGER
indicates that death or severe personal injury will result if proper precautions are not taken.
 WARNING
indicates that death or severe personal injury may result if proper precautions are not taken.
 CAUTION
indicates that minor personal injury can result if proper precautions are not taken.
NOTICE
indicates that property damage can result if proper precautions are not taken.

If more than one degree of danger is present, the warning notice representing the highest degree of danger will be used. A notice warning of injury to persons with a safety alert symbol may also include a warning relating to property damage.

Qualified Personnel

The product/system described in this documentation may be operated only by **personnel qualified** for the specific task in accordance with the relevant documentation, in particular its warning notices and safety instructions. Qualified personnel are those who, based on their training and experience, are capable of identifying risks and avoiding potential hazards when working with these products/systems.

Proper use of Siemens products

Note the following:

 WARNING
Siemens products may only be used for the applications described in the catalog and in the relevant technical documentation. If products and components from other manufacturers are used, these must be recommended or approved by Siemens. Proper transport, storage, installation, assembly, commissioning, operation and maintenance are required to ensure that the products operate safely and without any problems. The permissible ambient conditions must be complied with. The information in the relevant documentation must be observed.

Trademarks

All names identified by ® are registered trademarks of Siemens AG. The remaining trademarks in this publication may be trademarks whose use by third parties for their own purposes could violate the rights of the owner.

Disclaimer of Liability

We have reviewed the contents of this publication to ensure consistency with the hardware and software described. Since variance cannot be precluded entirely, we cannot guarantee full consistency. However, the information in this publication is reviewed regularly and any necessary corrections are included in subsequent editions.

Introduction

Purpose of the Operating Instructions

These operating instructions support you when installing and connecting up devices of the SCALANCE XP-200 product group.

The configuration and the integration of the devices in a network are not described in these operating instructions.

Validity of the Operating Instructions

These operating instructions apply to the following devices:

- SCALANCE XP208
- SCALANCE XP208EEC
- SCALANCE XP208PoE EEC
- SCALANCE XP216
- SCALANCE XP216EEC
- SCALANCE XP216PoE EEC

Unless mentioned otherwise, the descriptions in these operating instructions refer to all devices of the SCALANCE XP-200 product group named above in the section on validity.

There are two variants of some devices, refer to the section "Product overview (Page 17)".

Designations used

Classification	Description	Terms used
Product line	The product line includes all devices and variants of all product groups. If information applies to all product groups within the product line, the term SCALANCE X-200 is used.	SCALANCE X-200
Product group	If information applies to all devices and variants of a product group, the term SCALANCE XP-200 is used.	SCALANCE XP-200
Device	If information relates to a specific device, the device name is used.	e.g. SCALANCE XP208PoE EEC

Documentation on configuration

You will find detailed information on configuring the devices in the following configuration manuals:

- SCALANCE XB-200/XP-200 Web Based Management
- SCALANCE XB-200/XP-200 Command Line Interface

You will find the configuration manuals here:

- on the data medium that ships with some products:
 - Product CD / product DVD
 - SIMATIC NET Manual Collection
- On the Internet pages of Siemens Industry Online Support (<https://support.industry.siemens.com/cs/ww/en/ps/21869/man>).

Further documentation

In the system manuals "Industrial Ethernet / PROFINET Industrial Ethernet" and "Industrial Ethernet / PROFINET passive network components", you will find information on other SIMATIC NET products that you can operate along with the devices of this product line in an Industrial Ethernet network.

There, you will find among other things optical performance data of the communications partner that you require for the installation.

You will find the system manuals here:

- On the data medium that ships with some products:
 - Product CD / product DVD
 - SIMATIC NET Manual Collection
- On the Internet pages of Siemens Industry Online Support under the following entry IDs:
 - 27069465 (<http://support.automation.siemens.com/WW/view/en/27069465>)
Industrial Ethernet / PROFINET Industrial Ethernet System Manual
 - 84922825 (<http://support.automation.siemens.com/WW/view/en/84922825>)
Industrial Ethernet / PROFINET - Passive network components System Manual

SIMATIC NET manuals

You will find the SIMATIC NET manuals here:

- On the data medium that ships with some products:
 - Product CD / product DVD
 - SIMATIC NET Manual Collection
- On the Internet pages of Siemens Industry Online Support (<https://support.industry.siemens.com/cs/ww/en/ps/15247>).

SIMATIC NET glossary

Explanations of many of the specialist terms used in this documentation can be found in the SIMATIC NET glossary.

You will find the SIMATIC NET glossary on the Internet at the following address:

50305045 (<http://support.automation.siemens.com/WW/view/en/50305045>)

Catalogs

You will find the order numbers for the Siemens products of relevance here in the following catalogs:

- SIMATIC NET Industrial Communication / Industrial Identification, catalog IK PI
- SIMATIC Products for Totally Integrated Automation and Micro Automation, catalog ST 70
- Industry Mall - catalog and ordering system for automation and drive technology, Online catalog
(<https://eb.automation.siemens.com/goos/WelcomePage.aspx?regionUrl=/en&language=en>)

You can request the catalogs and additional information from your Siemens representative.

Unpacking and checking

 WARNING
Do not use any parts that show evidence of damage
If you use damaged parts, there is no guarantee that the device will function according to the specification.
If you use damaged parts, this can lead to the following problems:
<ul style="list-style-type: none">• Injury to persons• Loss of the approvals• Violation of the EMC regulations• Damage to the device and other components
Use only undamaged parts.

1. Make sure that the package is complete.
2. Check all the parts for transport damage.

Security information

Siemens provides products and solutions with industrial security functions that support the secure operation of plants, systems, machines and networks.

In order to protect plants, systems, machines and networks against cyber threats, it is necessary to implement – and continuously maintain – a holistic, state-of-the-art industrial security concept. Siemens' products and solutions only form one element of such a concept.

Customer is responsible to prevent unauthorized access to its plants, systems, machines and networks. Systems, machines and components should only be connected to the enterprise network or the internet if and to the extent necessary and with appropriate security measures (e.g. use of firewalls and network segmentation) in place.

Additionally, Siemens' guidance on appropriate security measures should be taken into account. For more information about industrial security, please visit <http://www.siemens.com/industrialsecurity> (<http://www.siemens.com/industrialsecurity>)

Siemens' products and solutions undergo continuous development to make them more secure. Siemens strongly recommends to apply product updates as soon as available and to always use the latest product versions. Use of product versions that are no longer supported, and failure to apply latest updates may increase customer's exposure to cyber threats.

To stay informed about product updates, subscribe to the Siemens Industrial Security RSS Feed under

<https://support.industry.siemens.com/cs/ww/en/ps/15247/pm>
(<https://support.industry.siemens.com/cs/ww/en/ps/15247/pm>).

Trademarks

The following and possibly other names not identified by the registered trademark sign ® are registered trademarks of Siemens AG:

SIMATIC NET, SCALANCE, C-PLUG, OLM

Electrostatic discharge



NOTICE

Electrostatic sensitive devices (ESD)

Electronic modules contain electrostatic sensitive components

These components can easily be destroyed if handled incorrectly.

Note the following instructions to avoid damage.

- Touch electronic modules only when you absolutely need to work on them.
- If electronic modules need to be touched, the body of the person involved must first be electrostatically discharged and grounded.
- Do not bring electronic modules in contact with electrically isolating materials such as plastic film, isolating table top pads or clothing made of synthetic fibers.
- Place the modules only on conductive surfaces.
- Pack, store and transport electronic modules and components only in conductive packaging such as metalized plastic or metal containers, conductive foam or household aluminum foil.

Table of contents

	Introduction	3
1	Safety notices	11
1.1	Security recommendations	12
2	Description of the device	17
2.1	Product overview	17
2.2	Device views	24
2.2.1	Device view of a SCALANCE XP208 and SCALANCE XP208EEC	24
2.2.2	Device view of a SCALANCE XP208PoE EEC	25
2.2.3	Device view of a SCALANCE XP216 and SCALANCE XP216EEC	26
2.2.4	Device view of a SCALANCE XP216PoE EEC	27
2.3	LED display	28
2.3.1	Overview	28
2.3.2	"RM" LED	28
2.3.3	"SB" LED	29
2.3.4	"F" LED	29
2.3.5	LEDs "DM1" and "DM2"	29
2.3.6	LEDs "L1" and "L2"	30
2.3.7	Port LEDs	31
2.4	RESET button	33
2.5	SELECT / SET button	35
2.6	C-PLUG	37
2.6.1	Function of the C-PLUG	37
2.6.2	Replacing the C-PLUG	38
2.7	Power over Ethernet (PoE)	41
3	Installation	45
3.1	Safety notices for installation	45
3.2	Types of installation	47
3.3	Wall mounting	47
3.4	Wall mounting	48
3.5	Rack mounting	49
4	Connecting up	51
4.1	Safety when connecting up	51
4.2	Industrial Ethernet	53
4.3	24 VDC power supply	56
4.4	54 VDC power supply	58

4.5	Signaling contact.....	60
4.6	Serial interface	62
4.7	Functional ground	64
5	Upkeep and maintenance	67
5.1	Downloading new firmware using TFTP without WBM and CLI	67
5.2	Restoring the factory settings	69
6	Technical specifications	71
6.1	Technical specifications SCALANCE XP208 and SCALANCE XP208EEC.....	71
6.2	Technical specifications of the SCALANCE XP208PoE EEC	73
6.3	Technical specifications SCALANCE XP216 and SCALANCE XP216EEC.....	75
6.4	Technical specifications of the SCALANCE XP216PoE EEC	77
6.5	Cable lengths	78
6.6	Switching properties.....	79
7	Dimension drawings.....	81
A	Approvals	85
	Index	93

Safety notices

Read the safety notices

Note the following safety notices. These relate to the entire working life of the device.

You should also read the safety notices relating to handling in the individual sections, particularly in the sections "Installation" and "Connecting up".

NOTICE
Loss of water and dust protection If you open the device, it loses its water and dust protection. <ul style="list-style-type: none">• Do not open the device. If this is not adhered to, the manufacturer's guarantee is lost.

NOTICE
Cleaning the housing Only clean the outer parts of the housing with a dry cloth. Do not use any liquids or solvents.

Safety notices on use in hazardous areas

General safety notices relating to protection against explosion

 WARNING
EXPLOSION HAZARD Do not open the device when the supply voltage is turned on.

Safety notices when using the device according to Hazardous Locations (HazLoc)

If you use the device under HazLoc conditions you must also keep to the following safety notices in addition to the general safety notices for protection against explosion:

This equipment is suitable for use in Class I, Division 2, Groups A, B, C and D or non-hazardous locations only.

This equipment is suitable for use in Class I, Zone 2, Group IIC or non-hazardous locations only.

1.1 Security recommendations

NOTICE
Information security Connect to the device and change the standard passwords for the users "admin" and "user" before you operate the device. To be able to change passwords you need to be logged in with write access to the configuration data.

To prevent unauthorized access, note the following security recommendations.

General

- You should make regular checks to make sure that the device meets these recommendations and/or other security guidelines.
- Evaluate your plant as a whole in terms of security. Use a cell protection concept with suitable products.
- When confidential zones are used, the internal and external network are disconnected, an attacker cannot access the data from the outside.
- Operate the device only within a protected network area.
- Use additional devices with VPN functionality (e.g. SCALANCE S) to encrypt and authenticate communication from and to the devices.
- For data transfer via a non-secure network, use an encrypted VPN tunnel (IPsec) by using additional devices with VPN functionality (e.g. SCALANCE S).
- For operation of the device in a non-secure infrastructure no product liability will be accepted.
- Separate connections correctly (WBM, Telnet, SSH etc.).

Physical access

- Limit physical access to the device to qualified personnel.
The memory card or the C-PLUG contains sensitive data such as certificates, keys etc. that can be read out and modified.
- Lock unused physical ports on the device. Unused ports can be used to gain forbidden access to the plant.

Software (security functions)

- Keep the software up to date. Check regularly for security updates of the product. You will find information on this on the Internet pages "Industrial Security (<http://www.siemens.com/industrialsecurity>)"
- Inform yourself regularly about security advisories and bulletins published by Siemens productCERT (<http://www.siemens.com/cert/en/cert-security-advisories.htm>).
- Only activate protocols that you really require to use the device.

- Restrict access to the device with a firewall or rules in an access control list (ACL - Access Control List).
- Restrict access to the management of the device with rules in an access control list (ACL).
- The option of VLAN structuring provides good protection against DoS attacks and unauthorized access. Check whether this is practical or useful in your environment.
- Enable logging functions. Use the central logging function to log changes and access attempts centrally. Check the logging information regularly.
- Configure a Syslog server to forward all logs to a central location.

Passwords

- Define rules for the use of devices and assignment of passwords.
- Regularly update passwords and keys to increase security.
- Change all default passwords for users before you operate the device.
- Only use passwords with a high password strength. Avoid weak passwords for example password1, 123456789, abcdefgh.
- Make sure that all passwords are protected and inaccessible to unauthorized personnel.
- Do not use the same password for different users and systems or after it has expired.

Keys and certificates

This section deals with the security keys and certificates you require to set up SSL.

- We strongly recommend that you create your own SSL certificates and make them available.

There are preset certificates and keys on the device. The preset and automatically created SSL certificates are self-signed. We recommend that you use SSL certificates signed either by a reliable external or by an internal certification authority. The device has an interface via which you can import the certificates and keys.

- Use the certification authority including key revocation and management to sign the certificates.
- Handle user-defined private keys with great caution if you use user-defined SSH or SSL keys.
- Verify certificates and fingerprints on the server and client to avoid "man in the middle" attacks.
- We recommend that you use certificates with a key length of 2048 bits.
- Change keys and certificates immediately, if there is a suspicion of compromise.

Secure/non-secure protocols

- Avoid or disable non-secure protocols, for example Telnet and TFTP. For historical reasons, these protocols are still available, however not intended for secure applications. Use non-secure protocols on the device with caution.
- Avoid or disable non-secure protocols. Check whether use of the following protocols is necessary:
 - PROFINET
 - Broadcast pings
 - Non authenticated and unencrypted interfaces
 - ICMP (redirect)
 - MRP, HRP
 - GMRP and IGMP
 - LLDP
 - Syslog
 - RADIUS
 - DHCP Options 66/67
 - TFTP
 - GMRP and GVRP
 - Multicast routing
- The following protocols provide secure alternatives:
 - SNMPv1/v2 → SNMPv3

Check whether use of SNMPv1 is necessary. SNMPv1 is classified as non-secure. Use the option of preventing write access. The product provides you with suitable setting options.

If SNMP is enabled, change the community names. If no unrestricted access is necessary, restrict access with SNMP.

Use SNMPv3 in conjunction with passwords.
 - HTTP → HTTPS
 - TFTP → FTPS
 - Telnet → SSH
 - SNTP → NTP
- Use secure protocols when access to the device is not prevented by physical protection measures.
- To prevent unauthorized access to the device or network, take suitable protective measures against non-secure protocols.
- If you require non-secure protocols and services, operate the device only within a protected network area.

- Restrict the services and protocols available to the outside to a minimum.
- For the DCP function, enable the "DCP read-only" mode after commissioning.

Port security

- Use port security functions (IEEE 802.1X).
- Enable port authentication on the ports of end devices.
- Use the function "Locked Ports" to block ports for unknown nodes.
- Configure the ports, e.g. edge ports, receive ports, unused ports to block all unnecessary protocols and services.
- Configure the receive ports so that they discard all untagged frames (Tagged Frames Only).

Available protocols per port

The following list provides you with an overview of the open ports on this device. Keep this in mind when configuring a firewall.

The table includes the following columns:

- **Protocol**
All protocols that the device supports
- **Port number**
Port number assigned to the protocol
- **Port status**
 - Open
The port is always open and cannot be closed.
 - Open (when configured)
The port is open if it has been configured.

Note

With some protocols the port may be open although the corresponding protocol is disabled, for example TFTP.

- **Default status of the port**
 - Open
As default the port is open.
 - Closed
As default the port is closed.
- **Authentication**
Specifies whether or not the protocol is authenticated during access.

1.1 Security recommendations

Protocol	Port number	Port status	Default status of the port	Authentication
SSH	TCP/22	Open (when configured)	Open	Yes
HTTP	TCP/80	Open (when configured)	Open	Yes
HTTPS	TCP/443	Open (when configured)	Open	Yes
SNTP NTP	UDP/123	Open (when configured)	Closed	No
SNMP	UDP/161	Open (when configured)	Open	Yes
PROFINET IO	UDP/34964, UDP/49154, 49155	Open	Open	No
Syslog	UDP/514	Open (when configured)	Open	No
TELNET	TCP/23	Open (when configured)	Open	Yes
EtherNet/IP	TCP/44818, UDP/2222,4481 8	Open (when configured)	Open	No
DHCP	UDP/67,68	Open (when configured)	Closed	No
RADIUS	UDP/1812,1813	Open (when configured)	Closed	No
TFTP	UDP/69	Open (when configured)	Closed	No

Description of the device

2.1 Product overview

Article numbers

There are two variants of some devices with different article numbers. These variants differ only in their factory settings. All other properties are identical.

Device	Description	Article number (Ethernet/IP)	Article number (PROFINET)
SCALANCE XP208	8 x 10/100 Mbps M12 connector technology electrical	6GK5 208-0HA00-2TS6	6GK5 208-0HA00-2AS6
SCALANCE XP208EEC	8 x 10/100 Mbps M12 connector technology electrical, varnished circuit board	-	6GK5 208-0HA00-2ES6
SCALANCE XP208PoE EEC	8 x 10/100 Mbps M12 connector technology electrical, varnished circuit board, Power over Ethernet on 4 ports	-	6GK5 208-0UA00-5ES6 ¹⁾
SCALANCE XP216	12 x 10/100 Mbps and 4 x 10/100/1000 Mbps M12 connector technology electrical	6GK5 216-0HA00-2TS6	6GK5 216-0HA00-2AS6
SCALANCE XP216EEC	12 x 10/100 Mbps and 4 x 10/100/1000 Mbps M12 connector technology electrical, varnished circuit board	-	6GK5 216-0HA00-2ES6
SCALANCE XP216PoE EEC	12 x 10/100 Mbps und 4 x 10/100/1000 Mbps M12 connector technology electrical, varnished circuit board, Power over Ethernet on 8 ports	-	6GK5 216-0UA00-5ES6 ¹⁾

¹⁾ The PoE variants SCALANCE XP-200 are expected to be available as of the second half of 2016.

Factory settings

EtherNet/IP variants

- Industrial Ethernet protocol: EtherNet/IP
- Base bridge mode: 802.1Q VLAN Bridge
- Redundancy mechanism: RSTP
- Trust mode: Trust COS-DSCP

PROFINET variants

- Industrial Ethernet protocol: PROFINET
- Base bridge mode: 802.1D transparent bridge
- Redundancy mechanism: Ring redundancy
- Trust mode: Trust COS

Type designation

The type designation of a SCALANCE XP-200 is made up of several parts that have the following meaning:

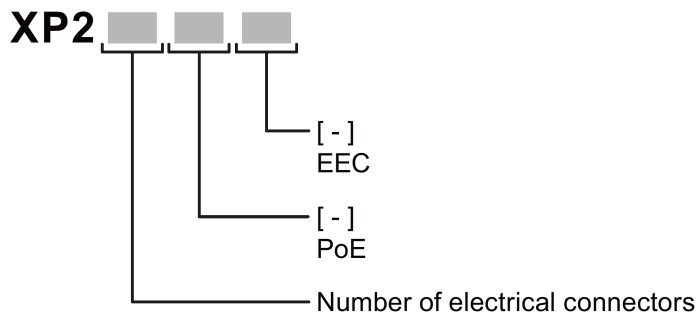

Property	Description
EEC	Enhanced Environmental Conditions
PoE	Power over Ethernet

Components of the product

The following components are supplied with a SCALANCE XP-200:

- One device
- One product DVD with documentation and software
- Protective caps for all connectors
- 4 screws for mounting on a rack
- Grounding screw

Accessories

The following accessories are available for SCALANCE XP-200:

C-PLUG

Component	Description	Article number
C-PLUG	Configuration plug, exchangeable storage medium for configuration data	6GK1 900-0AB00
	Configuration plug, Exchangeable storage medium for configuration data, Varnished (conformal coating)	6GK1 900-0AQ00

M12 data plug-in connector

Component	Description	Article number	
IE FC M12 PLUG PRO 2x2	M12 data plug-in connector for IE FC TP cables 2x2, IP65/67, D-coded, axial cable outlet	1 connector per package	6GK1 901-0DB20-6AA0
		8 connectors per package	6GK1 901-0DB20-6AA8
IE FC M12 PLUG PRO 4x2	M12 data plug-in connector for IE FC TP cables 4x2, IP65/67, X-coded, axial cable outlet	1 connector per package	6GK1 901-0DB30-6AA0
		8 connectors per package	6GK1 901-0DB30-6AA8
IE FC M12 CABLE CONNECTOR PRO 4X2	M12 plug-in connector (X-coded) can be assembled in the field, 8-pin, metal housing, FC fast connection technology, socket insert	1 connector per package	6GK1 901-0DB40-6AA0
		8 connectors per package	6GK1 901-0DB40-6AA8

Data line

Component	Description	Article number
Connecting cable (M12/RS-232)	Preassembled, serial cable with M12 and RS-232 plug, Length: 3 m pack of 1	6GK5 980-3BC00-0AA5
IE FC TP STANDARD CABLE GP2X2 (PROFINET type A)	Standard bus cable, TP installation cable for connection to FC OUTLET RJ-45, for universal use, 4-wire, shielded, CAT 5E Sold by the meter	6XV1 840-2AH10

2.1 Product overview

Component	Description	Article number
IE FC TP ROBUST STANDARD CABLE GP 2X2 (PROFINET type A)	Standard bus cable, ATPE outer jacket for connection to FC RJ45 PLUG and FC OUTLET RJ45, fixed installation, for universal use, 4-wire, shielded, CAT 5 Sold by the meter	6XV1 841-2A
IE FC TP ROBUST FLEXIBLE CABLE GP 2X2 (PROFINET type B)	Flexible bus cable, TPE outer jacket for connection to FC RJ45 PLUG and FC OUTLET RJ45, flexible wires, 4-wire, shielded, CAT 5 Sold by the meter	6XV1 841-2B
IE FC TP FLEXIBLE CABLE GP 2X2 (PROFINET type B)	Flexible bus cable, TP installation cable, flexible wires, shielded, CAT 5 Sold by the meter	6XV1 870-2B
IE FC TP TRAILING CABLE 2X2 (PROFINET type C)	Highly flexible bus cable, TP installation cable for connection to FC OUTLET RJ45, for use in drag chains, 4-wire, shielded, CAT 5 Sold by the meter	6XV1 840-3AH10
IE TP TORSION CABLE 2X2 (PROFINET type C)	Highly flexible bus cable, TP installation cable for use in highly flexible applications (torsion), 4-wire Sold by the meter	6XV1 870-2F
IE FC TP STANDARD CABLE GP 4X2	Shielded TP installation cable for connection to IE FC RJ45 PLUG 4X2, CAT 6, AWG 24 Sold by the meter	6XV1 878-2A
IE FC TP FLEXIBLE CABLE GP 4X2	Shielded TP installation cable for connection to IE FC RJ45 PLUG 4X2, flexible wires, CAT 6, 24 AWG Sold by the meter	6XV1 878-2B
IE CONNECTING CABLE M12-180/IE RJ45	Flexible IE connecting cable, 4-wire, preassembled with a 4-pin M12 plug (D-coded) and an IE FC RJ-45 Plug 145	6XV1 871-5T*
IE CONNECTING CABLE M12-180/M12-180	Flexible IE connecting cable, 4-wire, preassembled with two 4-pin M12 plugs (D-coded)	6XV1 870-8A*

* Available in different lengths

Cabinet feedthrough

Component	Description	Article number
IE M12 PANEL FEEDTHROUGH	Cabinet feedthrough for conversion from M12 connector technology (D-coded, IP65) to RJ-45 connector technology (IP20) pack of 5	6GK1 901-0DM20-2AA5
IE M12 PANEL FEEDTHROUGH PRO	Cabinet feedthrough for conversion from M12 connector technology (D-coded, IP65) to M12 connector technology (D-coded, IP65) pack of 5	6GK1 901-0DM30-2AA5
IE M12 PANEL FEEDTHROUGH 4X2	Cabinet feedthrough for conversion from M12 connector technology (X-coded, IP65/67) to R-45 connector technology (X-coded, IP20) pack of 5	6GK1 901-0DM40-2AA5

Power supply unit

Component	Description	Article number
SITOP PSU100P	Stabilized power supply, input: 120 to 230 VAC, output 24 VDC/5A IP67	6EP1 333-7CA00
	Stabilized power supply, input: 120 to 230 VAC, output 24 VDC/8A IP67	6EP1 334-7CA00

* Available in different lengths

Energy cable

Component	Description	Article number
Energy cable 2 x 0.75	Energy cable for connection of signaling contact and power supply 24 VDC, stranded wire 2 x 0.75 mm ² , capable of trailing, not assembled Sold by the meter	6XV1 812-8A
Robust Energy Cable 4 x 0,75	Energy cable for connection of power supply 24 VDC, 4-wire stranded 2 x 0.75 mm ² , robust, flexible, not assembled Sold by the meter	6XV1 801-2A
M12 PLUG-IN CABLE	Flexible plug-in power cable to connect the power supply 24 VDC, 4-wire, pre-assembled with a 4-pin M12 plug and an M12 socket (A-coded)	6XV1 801-5D*

* Available in different lengths

Socket

Component	Description	Article number
IE POWER M12 CABLE CONNECTOR PRO	Socket for the 24 V DC power supply. 4-pin, A-coded pack of 3	6GK1 907-0DC10-6AA3
SIGNALLING CONTACT M12 CABLE CONNECTOR	Socket for the signaling contact, 5-pin, B-coded pack of 3	6GK1 908-0DC10-6AA3

M12 Power T-Tap

Component	Description	Article number
M12 Power T-Tap	Power T tap with two M12 sockets and one M12 plug, see also section "24 VDC power supply (Page 56)" pack of 5	6GK1 907-0DC00-6AA5

Rack (ET200PRO)

Component	Description	Article number
Rack narrow	Length: 500 mm (ready for installation) pack of 1	6ES7 194-4GA00-0AA0
	Length: 1000 mm (ready for installation) pack of 1	6ES7 194-4GA60-0AA0
	Length: 2000 mm, pack of 1	6ES7 194-4GA20-0AA0
Rack wide	Length: 500 mm (ready for installation) pack of 1	6ES7 194-4GB00-0AA0
	Length: 1000 mm (ready for installation) pack of 1	6ES7 194-4GB60-0AA0
	Length: 2000 mm, pack of 1	6ES7 194-4GB20-0AA0
Rack compact narrow	Length: 500 mm (ready for installation) pack of 1	6ES7 194-4GC70-0AA0
	Length: 1000 mm (ready for installation) pack of 1	6ES7 194-4GC60-0AA0
	Length: 2000 mm, pack of 1	6ES7 194-4GC20-0AA0
Rack compact wide	Length: 500 mm (ready for installation) pack of 1	6ES7 194-4GD00-0AA0
	Length: 1000 mm (ready for installation) pack of 1	6ES7 194-4GD10-0AA0
	Length: 2000 mm, pack of 1	6ES7 194-4GD20-0AA0

Spare parts

The following spare parts are available for SCALANCE XP-200:

Component	Description	Article number
M12 protective caps	Protective caps to protect unused M12 sockets and plugs Pack of 8 for sockets and 2 for plugs	6GK5 980-2FA00-0AA0

2.2 Device views

2.2.1 Device view of a SCALANCE XP208 and SCALANCE XP208EEC

The following figure shows an overview of the components of the SCALANCE XP208 and SCALANCE XP208EEC.

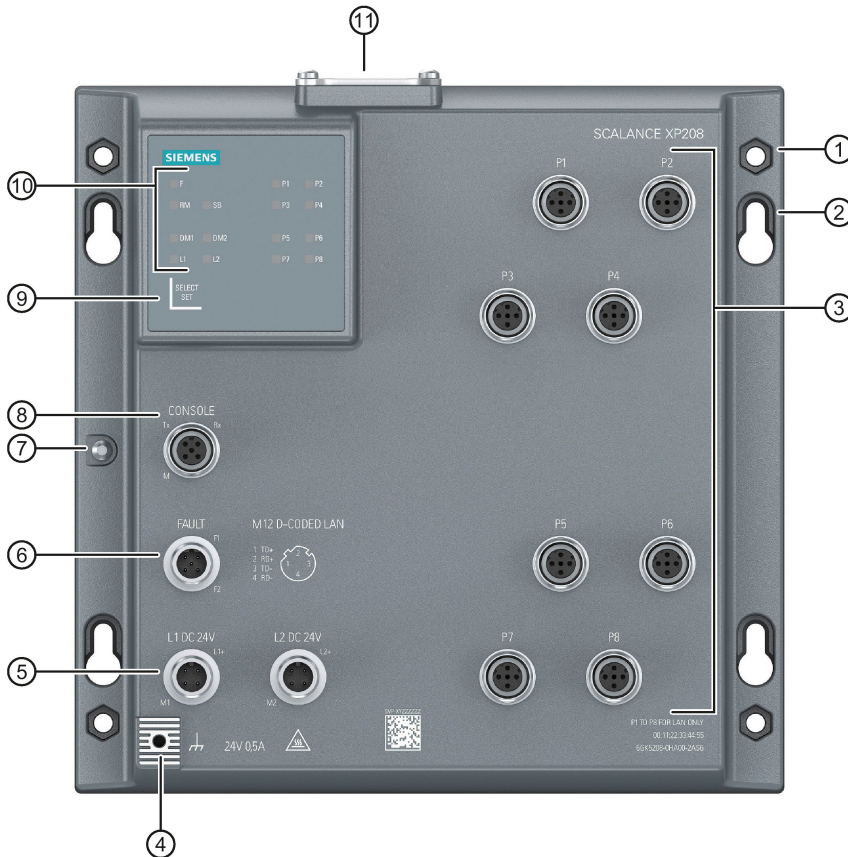

- ① Cutout for hexagonal nuts
- ② Keyhole hang-up mechanism
- ③ Ethernet ports for Fast Ethernet
- ④ Grounding point
- ⑤ Power supply (redundant)
- ⑥ Signaling contact
- ⑦ Securing point for covering the serial interface
- ⑧ Serial interface
- ⑨ "SELECT / SET" button
- ⑩ LED display
- ⑪ Cover for:
 - C-PLUG slot
 - "RESET" button

2.2.2 Device view of a SCALANCE XP208PoE EEC

The following figure shows an overview of the components of the SCALANCE XP208PoE EEC

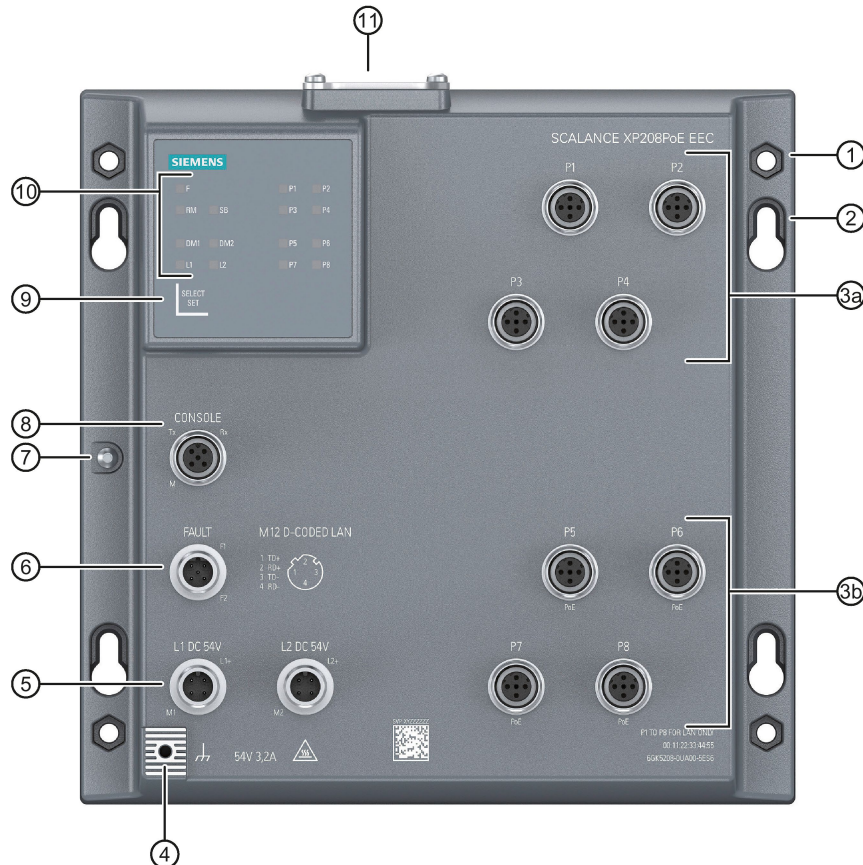

- ① Cutout for hexagonal nuts
- ② Keyhole hang-up mechanism
- ③
 - a Ethernet ports for Fast Ethernet (P1 - P4)
 - b Ethernet ports for Fast Ethernet and PoE (P5 - P8)
- ④ Grounding point
- ⑤ Power supply (redundant)
- ⑥ Signaling contact
- ⑦ Securing point for covering the serial interface
- ⑧ Serial interface
- ⑨ "SELECT / SET" button
- ⑩ LED display
- ⑪ Cover for:
 - C-PLUG slot
 - "RESET" button

2.2.3 Device view of a SCALANCE XP216 and SCALANCE XP216EEC

The following figure shows an overview of the components of the SCALANCE XP216 and SCALANCE XP216EEC.

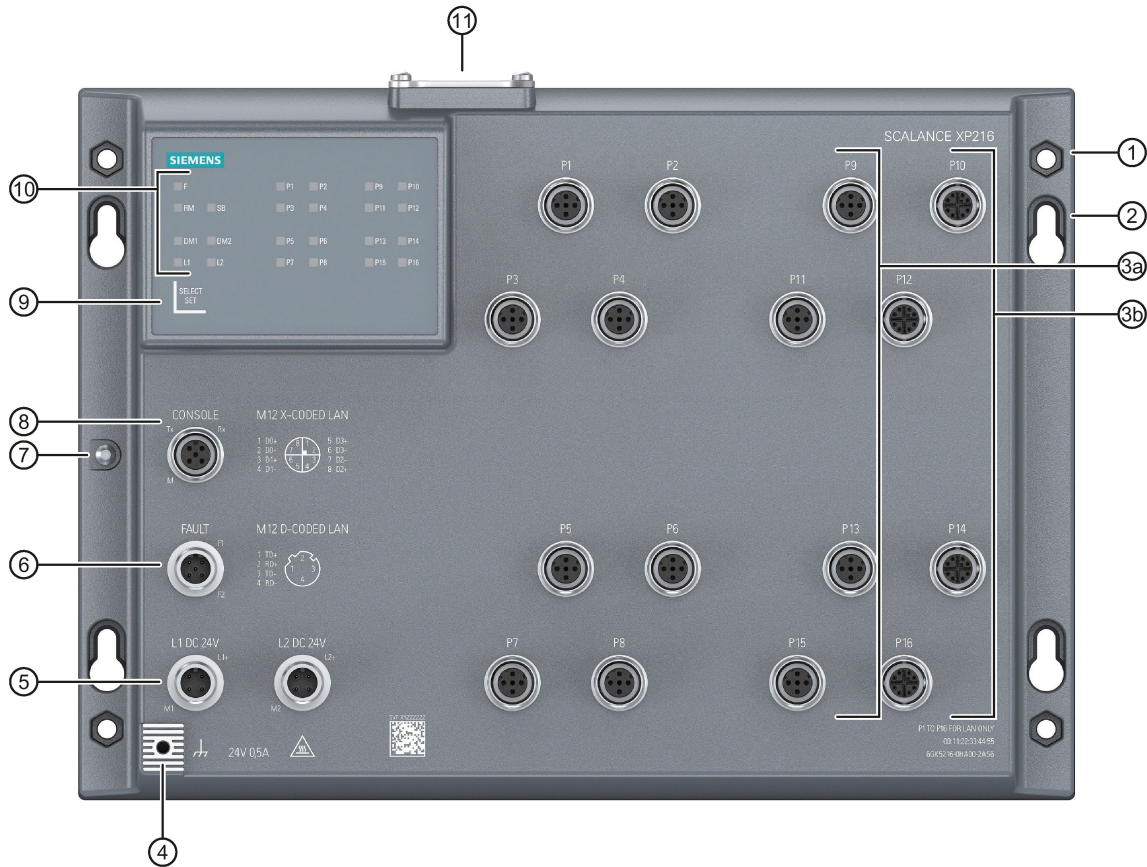

- ① Cutout for hexagonal nuts
- ② Keyhole hang-up mechanism
- ③ a Ethernet ports for Fast Ethernet (P1 - P8, P9, P11, P13 and P15)
- b Ethernet ports for Gigabit Ethernet (P10, P12, P14 and P16)
- ④ Grounding point
- ⑤ Power supply (redundant)
- ⑥ Signaling contact
- ⑦ Securing point for covering the serial interface
- ⑧ Serial interface
- ⑨ "SELECT / SET" button
- ⑩ LED display
- ⑪ Cover for:
 - C-PLUG slot
 - "RESET" button

2.2.4 Device view of a SCALANCE XP216PoE EEC

The following figure shows an overview of the components of the SCALANCE XP216PoE EEC.

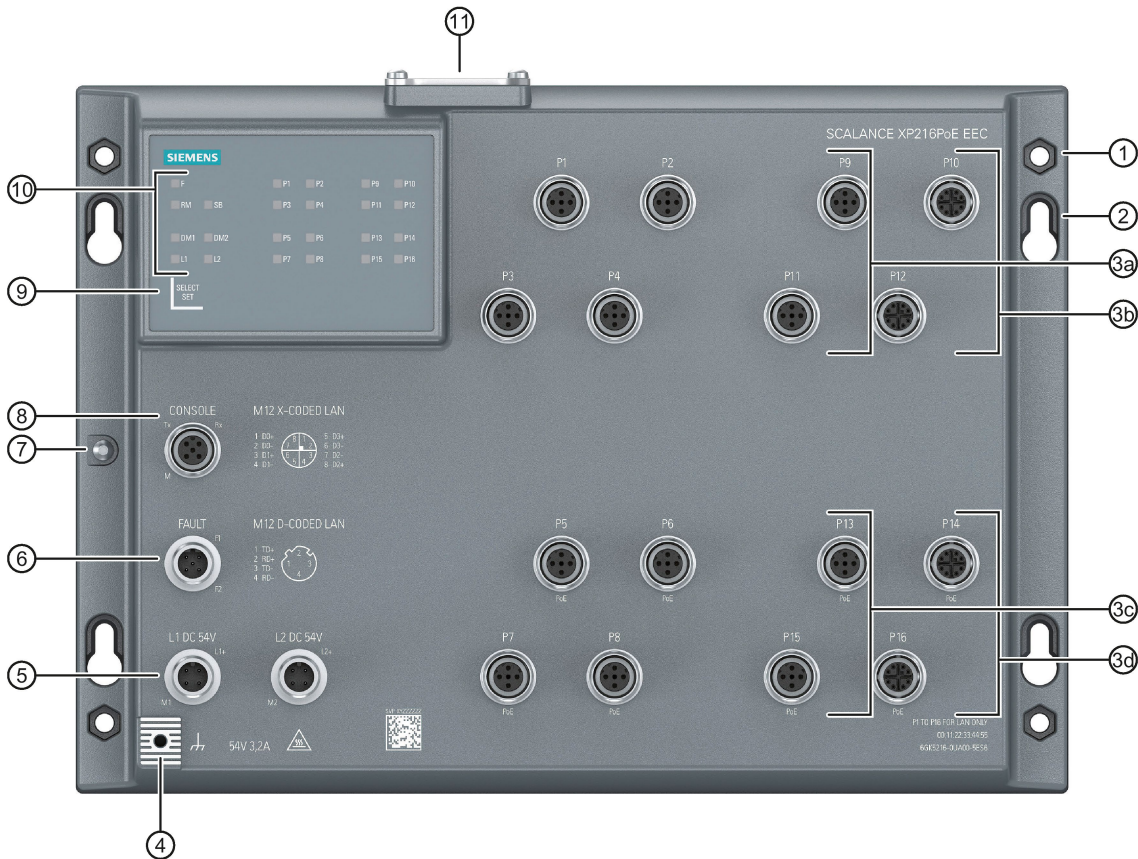

- ① Cutout for hexagonal nuts
- ② Keyhole hang-up mechanism
- ③
 - a Ethernet ports for Fast Ethernet (P1 - P4, P9 and P11)
 - b Ethernet ports for Gigabit Ethernet (P10 und P12)
 - c Ethernet ports for Fast Ethernet and PoE (P5 - P8, P13 and P15)
 - d Ethernet ports for Gigabit Ethernet and PoE (P14 and P16)
- ④ Grounding point
- ⑤ Power supply (redundant)
- ⑥ Signaling contact
- ⑦ Securing point for covering the serial interface
- ⑧ Serial interface
- ⑨ "SELECT / SET" button
- ⑩ LED display
- ⑪ Cover for:
 - C-PLUG slot
 - "RESET" button

2.3 LED display

2.3.1 Overview

The following figure shows the arrangement of the LEDs.

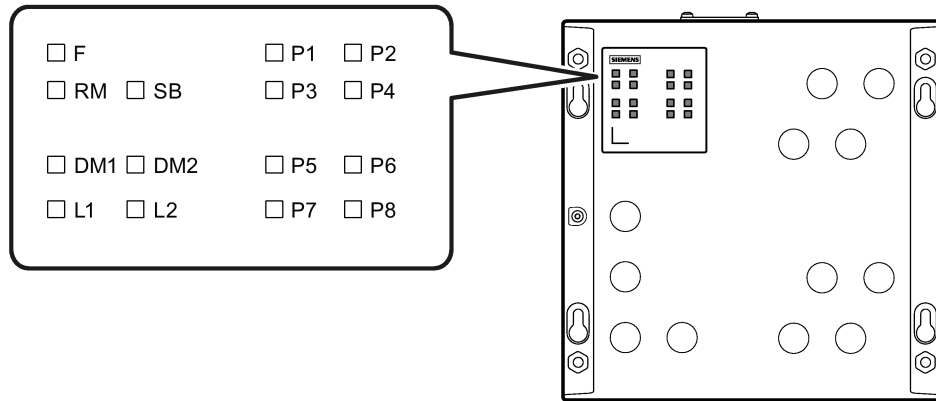

- F LED for displaying the fault/error status
- RM LED for displaying the "redundancy manager" function
- SB LED for displaying the "standby" function
- DM1/DM2 LEDs for displaying the display mode
- L1/L2 LEDs for displaying the power supply
- P LEDs for displaying the port status *)

*) The number of port LEDs depends on the device.

2.3.2 "RM" LED

The "RM" LED indicates whether or not the device is a redundancy manager and whether or not the ring is operating free of error.

LED color	LED status	Meaning
-	Off	The device is not a redundancy manager.
Green	On	The device is a redundancy manager. The ring is working without problems, monitoring is activated.
Green	Flashing	The device is a redundancy manager. An interruption has been detected on the ring and the device has switched through.

2.3.3 "SB" LED

The "SB" LED shows the status of the standby function.

LED color	LED status	Meaning
-	Off	The standby function is disabled.
Green	On	The standby function is enabled. The standby section is passive.
Green	Flashing	The standby function is enabled. The standby section is active.

2.3.4 "F" LED

The "F" LED shows the fault/error status of the device.

Meaning during device startup

LED color	LED status	Meaning during device startup
-	Off	Device startup was completed successfully.
Red	On	Device startup is not yet completed or errors have occurred.
Red	Flashing	There are errors in the firmware.

Meaning during operation

LED color	LED status	Meaning during operation
-	Off	The device is operating free of errors. detected The signaling contact is closed.
Red	On	The device has detected a problem. The signaling contact has opened.

2.3.5 LEDs "DM1" and "DM2"

The "DM1" and "DM2" LEDs indicate which display mode is set.

There are 5 display modes (A, B, C, D, and E). Display mode A is the default mode.

Depending on the set display mode, the "L1", "L2" LEDs and the port LEDs show different information.

LED color	LED status		Meaning
	DM1 LED	DM2 LED	
-	Off		Display mode A
Green	On	Off	Display mode B
Green	Off	On	Display mode C
Green	On		Display mode D
Green	Flashing	Off	Display mode E

2.3 LED display

Setting the display mode

To set the required display mode, press the "SELECT/SET" button.

If you do not press the "SELECT/SET" button for longer than 1 minute, the device automatically changes to display mode A.

Pressing SELECT/SET button starting at display mode A	LED status		Display mode
	DM1	DM2	
-	Off		Display mode A
Press once	On	Off	Display mode B
Press twice	Off	On	Display mode C
Press three times	On		Display mode D
Press four times	Flashing	Off	Display mode E

2.3.6 LEDs "L1" and "L2"

The "L1" and "L2" LEDs indicate the current range of the power supply at connectors L1 and L2.

The meaning of the "L1" and "L2" LEDs depends on the set display mode, see section "LEDs "DM1" and "DM2" (Page 29)".

Meaning in display modes A, B, C and E

In display modes A, B, C and E, from the "L1" and "L2" LEDs you can see whether the power supply is higher or lower than a certain voltage limit.

Table 2- 1 Power supply with devices with 24 VDC

L1/L2 LEDs		L1/L2 connector
LED color	LED status	
-	Off	Power supply too low
Green	On	Power supply is applied

Table 2- 2 Power supply with devices with 54 VDC

L1/L2 LEDs		L1/L2 connector
LED color	LED status	
-	Off	Power supply too low
Green	On	Power supply is applied

Meaning in display mode D

In display mode D, the "L1" and "L2" LEDs indicate whether the power supply is monitored.

Table 2- 3 Power supply with devices with 24 VDC

L1/L2 LED		L1/L2 connector
LED color	LED status	
-	Off	Power supply is not monitored. If the power supply is too low, the signaling contact does not respond.
Green	On	Power supply is monitored. If the power supply is too low, the signaling contact responds.

Table 2- 4 Power supply with devices with 54 VDC

L1/L2 LED		L1/L2 connector
LED color	LED status	
-	Off	Power supply is not monitored. If the power supply is too low, the signaling contact does not respond.
Green	On	Power supply is monitored. If the power supply is too low, the signaling contact responds.

2.3.7

Port LEDs

The port LEDs "P1", "P2" etc. show information about the corresponding ports.

The meaning of the Port LEDs depends on the set display mode, see section "LEDs "DM1" and "DM2" (Page 29)".

Meaning in display mode A

In display mode A, the port LEDs indicate whether a valid link exists.

LED color	LED status	Meaning
-	Off	No valid link to the port (for example station turned off or cable not connected).
Green	On	Link exists and port in normal status. In this status, the port can receive and send data.
	Flashes once per period*	Link exists and port in "blocking" status. In this status, the port only receives management data (no user data).
	Flashes three times per period*	Link exists and port turned off by management. In this status, no data is sent or received via the port.
	Flashes four times per period*	Link exists and is in the "monitor port" status. In this status, the data traffic of another port is mirrored to this port.
Yellow	Flashing / lit	Receiving data at port

* 1 period $\hat{=}$ 5 seconds

2.3 LED display

Meaning in display mode B

In display mode B, the port LEDs indicate the transmission speed.

LED color	LED status	Meaning
-	Off	Port operating at 10 Mbps
Green	On	Port operating at 100 Mbps
Orange	On	Port operating at 1000 Mbps

If there is a connection problem and the type of transmission is fixed (autonegotiation off), the desired status, in other words the set transmission speed (1000 Mbps, 100 Mbps, 10 Mbps) continues to be displayed. If there is a connection problem and autonegotiation is active, the port LED goes off.

Meaning in display mode C

In display mode C, the port LEDs indicate the mode.

LED color	LED status	Meaning
-	Off	Port operating in half duplex mode
Green	On	Port operating in full duplex mode

Meaning in display mode D

In display mode D, the port LEDs indicate whether the port is monitored.

LED color	LED status	Meaning
-	Off	Port is not monitored. If no link was established at the port the signaling contact does not indicate an error.
Green	On	Port is monitored. If no link was established at the port the signaling contact indicates an error.

Meaning in display mode E

In display mode E, the port LEDs indicate whether the connected device is supplied using PoE.

LED color	LED status	Meaning
-	Off	The connected device is not supplied using PoE.
Green	On	The connected device is supplied via PoE.

2.4 RESET button

Position

NOTICE**Loss of water and dust protection**

If the cover is not mounted correctly, the device is not water and dust proof.

The "RESET" button is located under the cover on the top of the SCALANCE XP-200.

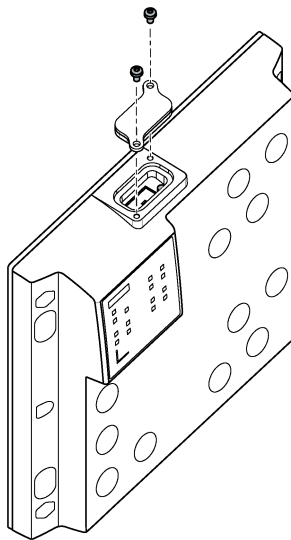

Figure 2-1 Position of the "RESET" button, for example on the SCALANCE XP208

Resetting the device to factory defaults

NOTICE**Previous settings**

If you reset, all the changes you have made will be overwritten by factory defaults.

NOTICE**Inadvertent reset**

An inadvertent reset can cause disturbances and failures in the configured network with further consequences.

2.4 RESET button

Requirement

- The device is in operation.
- The function "Reset to factory defaults" is enabled for the RESET button.

Note

Reset despite disabled "RESET button"

If you have disabled the "Restore Factory Defaults" function for the "RESET" button in the configuration, this does not apply during the startup phase, see section "Restoring the factory settings (Page 69)"

If the function has been disabled with the configuration, it is only disabled on completion of the startup phase.

Procedure

To reset the device to the factory defaults during operation, follow the steps below:

1. Loosen the screws of the cover.
2. Remove the cover.
3. Hold down the "RESET" button for 12 seconds.

Note

The RESET button is a long-stroke button with a pressure point.

Press the button until you feel the pressure point.

After 9 seconds, the "DM1" and "DM2" LEDs start to flash for 3 seconds. At the same time, the port LEDs go on one after the other.

After you have held down the button for 12 seconds, the factory defaults are restored.

If you release the button before the 12 seconds have elapsed, the reset is canceled.

4. Close the cover (tightening torque = 0.8 Nm), to ensure that the device is closed and water and dust proof.

Enabling and disabling the button

With the configuration, you can enable or disable the button function.

2.5 SELECT / SET button

NOTICE
Loss of water and dust protection
If the film of the button is damaged, the device is not water and dust proof.
Make sure that the film of the button does not get damaged. Do not use e.g. sharp objects to press the button.

Position

The "SELECT/SET" button is located on the front of the SCALANCE XP-200.

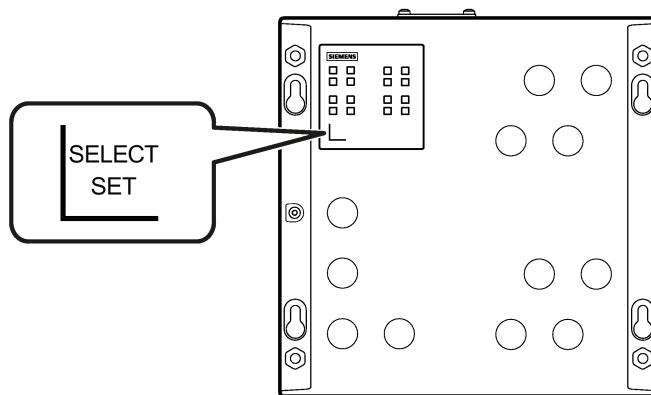

Figure 2-2 SELECT/SET button

Setting the display mode

To set the required display mode, press the "SELECT/SET" button.

For more detailed information on the display modes, refer to the section "LEDs "DM1" and "DM2" (Page 29)".

Defining the fault mask

Using the fault mask, you specify an individual "good status" for the connected ports and the power supply. Deviations from this status are displayed as errors/faults.

You configure the monitoring of plugged-in connections in the plant engineering.

To define the fault mask, follow the steps below:

1. Switch to display mode D.

Display mode D is active if the "DM1" and "DM2" LEDs are lit green..

If another display mode is active, you will need to press the "SET/SELECT" button repeatedly until the "DM1" and "DM2" LEDs are lit green.

2. Hold down the "SELECT/SET" button for 5 seconds.

After 2 seconds, the "DM1" and "DM2" LEDs start to flash for 3 seconds. At the same time, the port LEDs go on one after the other.

After you have held down the button for 5 seconds, the current settings are stored as the "good status".

If you release the button before the 5 seconds have elapsed, the previous fault mask will be retained.

Enabling/disabling the redundancy manager

To enable/disable the redundancy manager, follow the steps below:

1. Switch to display mode B.

Display mode B is active if the "DM1" LED is lit green and the "DM2" LED is off..

If another display mode is active, you will need to press the "SET/SELECT" button repeatedly until the "DM1" LED is lit green and the "DM2" LED is off.

2. Hold down the "SELECT/SET" button for 5 seconds.

After 2 seconds, the "DM1", "DM2" and "RM" LEDs start to flash for 3 seconds. At the same time, the port LEDs go on one after the other.

If you release the button before the 5 seconds have elapsed, the action is canceled.

The result of the action depends on the initial situation:

– **Initial situation:**

The redundancy manager and media redundancy are disabled.

Result:

After enabling the redundancy manager, media redundancy is also enabled.

– **Initial situation:**

The redundancy manager and media redundancy are enabled.

Result:

After disabling the redundancy manager, media redundancy remains enabled.

2.6 C-PLUG

2.6.1 Function of the C-PLUG

NOTICE
Do not remove or insert a C-PLUG during operation
A C-PLUG may only be removed or inserted when the device is turned off.

Saving the configuration data

A C-PLUG is an exchangeable storage medium for storing the configuration data of the device. This allows fast and uncomplicated replacement of a device. The C-PLUG is taken from the previous device and inserted in the new device. The first time it is started up, the replacement device has the same configuration as the previous device except for the device-specific MAC address set by the vendor.

A C-PLUG stores the current information about the configuration of a device.

Note

The device can also be operated without a C-PLUG.

How it works

Operating mode

In terms of the C-PLUG, there are three modes for the device:

- Without C-PLUG

The device stores the configuration in internal memory.

This mode is active if no C-PLUG is inserted.

- With unwritten C-PLUG

If an unwritten C-PLUG (factory status or deleted with Clean function) is used, the local configuration already existing on the device is automatically stored on the inserted C-PLUG during startup.

This mode is active as soon as an unwritten C-PLUG is inserted.

- With written C-PLUG

A device with a written and accepted C-PLUG uses the configuration data of the C-PLUG automatically when it starts up. The requirement for acceptance is that the data was written by a compatible device type.

If there is configuration data in the internal memory of the device this is overwritten.

This mode is active as soon as a written C-PLUG is inserted.

2.6 C-PLUG

Operation with C-PLUG

The configuration stored on the C-PLUG is displayed over the user interfaces.

If changes are made to the configuration, the device stores the configuration directly on the C-PLUG, if this is in the "ACCEPTED" status and in internal memory.

Response to errors

Inserting a C-PLUG that does not contain the configuration of a compatible device type and inadvertently removing the C-PLUG, or general malfunctions of the C-PLUG are indicated by the diagnostic mechanisms of the device.

- Fault LED
- Web Based Management (WBM)
- SNMP
- Command Line Interface (CLI)
- PROFINET diagnostics

The user then has the choice of either removing the C-PLUG again or selecting the option to reformat the C-PLUG.

2.6.2 Replacing the C-PLUG

Position of the C-PLUG

NOTICE
Loss of water and dust protection If the cover is not mounted correctly, the device is not water and dust proof.
NOTICE
Loss of the railway approval If you use an unvarnished C-PLUG, the device does not comply with the railway standard EN50155.
NOTICE
Do not remove or insert a C-PLUG during operation The C-PLUG may only be removed or inserted when the device is turned off. The device checks whether or not a C-PLUG is inserted at one second intervals. If it is detected that the PLUG was inserted or removed, there is a restart.

The C-PLUG slot is on the top of the device housing under a cover.

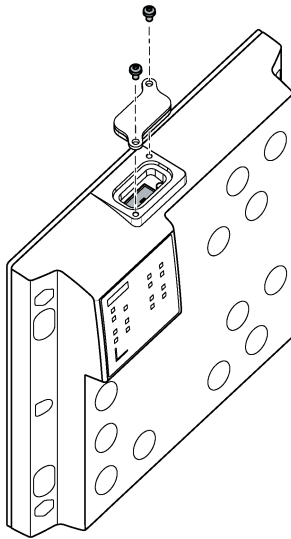

Replacing a C-PLUG.

Removing a C-PLUG

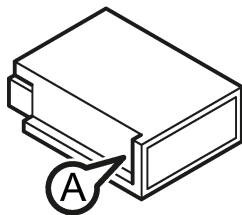

1. Turn off the power to the device.
2. Loosen the screws of the cover.
3. Remove the cover.
4. Insert a screwdriver between the front edge of the C-PLUG (A) and the slot and release the C-PLUG.
5. Remove the C-PLUG.
6. Close the cover (tightening torque = 0.8 Nm), to ensure that the device is closed and water and dust proof.

Note

Loss of the configuration

The "RESET (Page 33)" button is located directly beside the slot for the C-PLUG. The button cannot be used to remove the C-PLUG.

If you hold down the "RESET" button, you reset all settings of the device to the factory defaults.

Remove the C-PLUG with a screwdriver.

Inserting a C-PLUG

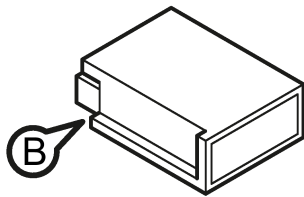

1. Turn off the power to the device.
2. Loosen the screws of the cover.
3. Remove the cover.
4. The housing of the C-PLUG has a protruding ridge on the long side (B). The slot has a groove at this position. Insert the C-PLUG correctly oriented into the slot.
5. Close the cover (tightening torque =.8 Nm), to ensure that the device is closed and water and dust proof.

2.7 Power over Ethernet (PoE)

Function

The "Power over Ethernet" function supplies connected devices with power via the Ethernet cable. Devices supplied with power via an Ethernet cable do not require a separate voltage source.

PoE-compliant devices can be divided into the following groups:

- Power source (PSE - Power Sourcing Equipment)
These inject power onto the Ethernet cable.
- Power consumer (PD - Powered Device)
These are supplied with power via the Ethernet cable.

Power and voltage range according to the standard

Note the values specified for the power of the power source, so that the power supply is ensured at the power consumers according to the standard.

		802.3at Type 1 - PoE	802.3at Type 2 - PoE+
Maximum power supplied by the power source		15.40 W	30.0 W
Available power at the power source		12.95 W	25.50 W
Voltage range	Power source	44.0 ... 57.0 V	50.0 ... 57.0 V
	Power consumer	37.0 ... 57.0 V	42.5 ... 57.0 V

PoE variants

The PoE variants of SCALANCE XP-200 are power sources and have 4 or 8 PoE ports. Via the PoE ports, devices capable of PoE can be supplied with power via the Ethernet cable.

Note

You can also use the PoE ports without the PoE function. A voltage is applied only after the device has detected an end device capable of PoE at the port. With devices not capable of PoE, only the data connection is used.

PoE ports

- The PoE ports are M12 sockets. Ports P5 to P8, P13 and P15 are D-coded, ports P14 and P16 are X-coded.
- Depending on the connected power supply, the device can supply power consumers of the standard IEEE 802.3at type 1 or type 2
- The PoE ports are not isolated from each other. This means that they meet the conditions named in Environment A (IEEE 802.3): Power supply over Ethernet within a power supply system.

The electrical isolation of the ports is designed for 500 Vrms (1 minute).

- The PoE ports are divided into port groups:
 - Ports P5 to P8
 - Ports P13 to P16

Devices with 8 ports have one port group, devices with 16 ports have two port groups.

- In total a power source can make a maximum of 120 W (incl. line losses) available. The power can be distributed to the port groups variably.
- Note the line losses. For example to supply power consumers with approx. 102 W, the connected PoE power supply must make at least 120 W available.
- If you use a Cat5/Cat5e cable with a maximum length of 100 m, the connected device can be supplied with a power of 25.5 W.

Note

Turn off the power source before you disconnect the PoE cable of a power consumer.

Configuration

How you activate and configure PoE is described in the configuration manuals, see section "Introduction (Page 3)", section "Documentation on configuration".

Power transfer and pin assignment

The voltage is transferred on the data wires 1, 2, 3 and 4 of the Ethernet cable.

D-coded ports

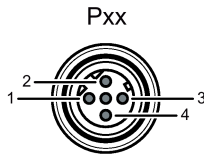

Pin number	Assignment
Pin 1	negative power supply
Pin 2	positive power supply
Pin 3	negative power supply
Pin 4	positive power supply

X-coded ports

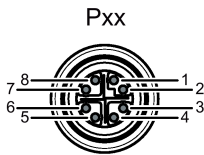

Pin number	Assignment
Pin 1	negative power supply
Pin 2	negative power supply
Pin 3	positive power supply
Pin 4	positive power supply
Pin 5	
Pin 6	
Pin 7	
Pin 8	

2.7 Power over Ethernet (PoE)

Installation

3.1 Safety notices for installation

Safety notices

When installing the device, keep to the safety notices listed below.

 WARNING
--

If a device is operated in an ambient temperature of more than 40 °C, the temperature of the device housing may be higher than 70 °C. The device must therefore be installed so that it is only accessible to service personnel or users that are aware of the reason for restricted access and the required safety measures at an ambient temperature higher than 40 °C.

 WARNING
--

If the device is installed in a cabinet, the inner temperature of the cabinet corresponds to the ambient temperature of the device.

Safety notices on use in hazardous areas

General safety notices relating to protection against explosion

 WARNING
--

EXPLOSION HAZARD

Replacing components may impair suitability for Class 1, Division 2 or Zone 2.
--

 WARNING
--

When used in hazardous environments corresponding to Class I, Division 2 or Class I, Zone 2, the device must be installed in a cabinet or a suitable enclosure.

Safety notices for use according to ATEX and IECEx

If you use the device under ATEX or IECEx conditions you must also keep to the following safety notices in addition to the general safety notices for protection against explosion:

 WARNING
To comply with EC Directive 2014/34/EU (ATEX 114) or the conditions of IECEx, this enclosure or cabinet must meet the requirements of at least IP54 in compliance with EN 60529.

 WARNING
If the cable or conduit entry point exceeds 70 °C or the branching point of conductors exceeds 80 °C, special precautions must be taken. If the equipment is operated in an air ambient in excess of 60 °C, only use cables with admitted maximum operating temperature of at least 80 °C.

Further notes

 CAUTION
Use only approved components If you use components and accessories that are not approved for SIMATIC NET devices or their target systems, this may violate the requirements and regulations for safety and electromagnetic compatibility. Only use components approved for the SIMATIC NET devices.

NOTICE
Warming and premature aging of the IE switch due to direct sunlight Direct sunlight can heat up the device and can lead to premature aging of the IE switch and its cabling. Provide suitable shade to protect the IE switch against direct sunlight.

Note

During installation and operation, keep to the installation guidelines and safety notices described in this document and in the system manuals "Industrial Ethernet / PROFINET Industrial Ethernet" and "Industrial Ethernet / PROFINET passive network components".

You will find information on the system manuals in the section "Introduction (Page 3)", in "Further documentation".

3.2 Types of installation

Types of installation

The SCALANCE XP-200 can be installed in the following ways:

- Wall mounting
- Wall mounting
- Rack mounting

3.3 Wall mounting

Note

Depending on the mounting surface, use suitable fittings.

Note

The wall mounting must be capable of supporting at least four times the weight of the device.

To mount the device on a wall, follow the steps below:

1. Prepare the drill holes for wall mounting. For the precise dimensions, refer to the section "Dimension drawings".
2. Screw the device to the wall using the keyhole hang-up mechanisms.
3. Fit the connectors for the power supply, see the section "Power supply".
4. Fit the connectors for the signaling contact, refer to the section ""Signaling contacts".

3.4 Wall mounting

Installation

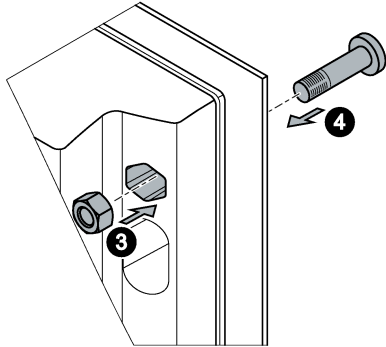

Figure 3-1 Wall mounting

To mount the device screwed from the back on a wall, follow the steps below:

1. Prepare the drill holes for mounting. For the precise dimensions, refer to the section "Dimension drawings (Page 81)".
2. Bring the drill holes and the cutouts for the hexagon nuts together so that they cover the same area.
3. Place the hexagon nuts in the corresponding cutouts. The nuts cannot be turned in the cutouts.
4. Push the screws through the drill holes and screw them to the nuts.
5. Fit the connectors for the power supply, see the section "Power supply (Page 56)".
6. Fit the connectors for the signaling contact, refer to the section "Signaling contact (Page 60)".

Removal

To remove the device from the wall, follow the steps below:

1. Disconnect all connected cables.
2. Loosen the screws.

3.5 Rack mounting

Mounting on a rack

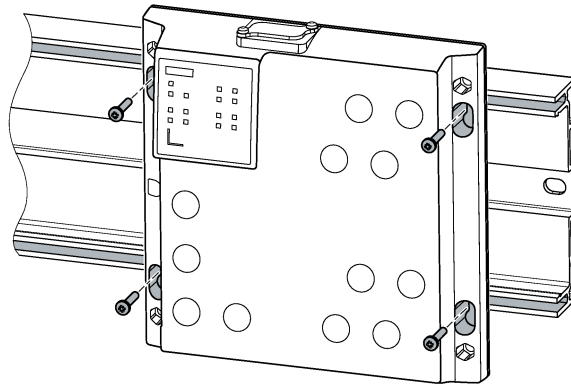

Figure 3-2 Mounting rack

To screw the device to a rack, you require fixing screws with the following properties:

- Self-tapping screw M5 x 20 mm
Four self-tapping screw M5 x 20 ship with the device.
- Screw head diameter: max. 7 mm

To install the device on a rack, follow the steps below:

1. Screw the device to the rack using the keyhole hang-up mechanisms, see also sections "Dimension drawings (Page 81)" and "Product overview (Page 17)".
2. Fit the connectors for the power supply, see the section "Power supply (Page 56)".
3. Fit the connectors for the signaling contact, refer to the section "Signaling contact (Page 60)".

Note

Grounding

The device is not grounded via the rack by the keyhole hang-up mechanisms.

If necessary connect a separate ground.

Removal

To remove the device from a rack, follow the steps below:

1. Disconnect all connected cables.
2. Loosen the screw connection.
3. Lift the device from the rack via the keyhole hang-up mechanisms.
4. Loosen the screws completely.

Connecting up

4.1 Safety when connecting up

Safety notices

When connecting up the device, keep to the safety notices listed below.

Safety extra low voltage

 WARNING
Power supply The device is designed for operation with a directly connectable safety extra-low voltage (SELV).

General notices

NOTICE
Suitable fusing for the power supply cables The current on the terminal may not exceed 5 A. Use a fuse, that protects against currents > 5 A. The fuse must meet the following requirements: <ul style="list-style-type: none"> • In areas where NEC or CEC applies: <ul style="list-style-type: none"> – Suitable for DC (min. 60 V / max. 5 A) – Breaking current at least 10 kA – Approval according to ANSI/UL 248-1 or CSA C22.2 No. 248.1 – Classes R, J, L, T or CC – Suitable for the protection of DC power supply circuits • In other areas: <ul style="list-style-type: none"> – Suitable for DC (min. 60 V / max. 5 A) – Breaking current at least 10 kA – Approval in compliance with IEC 60127-1 / EN 601127-1 – Switch off characteristics: B or C for circuit breakers and fuses – Suitable for the protection of DC power supply circuits <p>With 24 VDC devices you do not need to fuse the supply cable if you only use power sources with a limited power source (LPS) or power sources according to NEC Class 2 for the power supply of the devices.</p>

Note

Close unused sockets

Close all unused M12 sockets with protective caps (torque at least 0.4 Nm) to achieve the specified type of protection.

Safety notices on use in hazardous areas

General safety notices relating to protection against explosion

 **WARNING**

EXPLOSION HAZARD

Do not connect or disconnect cables to or from the device when a flammable or combustible atmosphere is present.

 **WARNING**

EXPLOSION HAZARD

Do not press the SELECT/SET button when there is an explosive atmosphere.

Safety notices when using the device according to Hazardous Locations (HazLoc)

If you use the device under HazLoc conditions you must also keep to the following safety notices in addition to the general safety notices for protection against explosion:

 **WARNING**

EXPLOSION HAZARD

DO NOT DISCONNECT WHILE CIRCUIT IS LIVE UNLESS AREA IS KNOWN TO BE NON-HAZARDOUS.

Safety notices for use according to ATEX and IECEx

If you use the device under ATEX or IECEx conditions you must also keep to the following safety notices in addition to the general safety notices for protection against explosion:

 **WARNING**

Take measures to prevent transient voltage surges of more than 40% of the rated voltage. This is the case if you only operate devices with SELV (safety extra-low voltage).

 WARNING
<p>Safety notice for connecting with a LAN ID (Local Area Network)</p> <p>A LAN or LAN segment with all the interconnected devices should be contained completely in a single low voltage power distribution in a building. The LAN is designed either for "Environment A" according to IEEE802.3 or "Environment 0" according to IEC TR 62102.</p> <p>Do not connect any electrical connectors directly to the telephone network (telephone network voltage) or a WAN (Wide Area Network).</p>

4.2 Industrial Ethernet

Ethernet ports

The attachment to Industrial Ethernet uses M12 connector technology with MDI-X assignment.

Fast Ethernet

For connection to Industrial Ethernet at 10/100 Mbps, the device has the following M12 interfaces: D-coded, 4-pin, female.

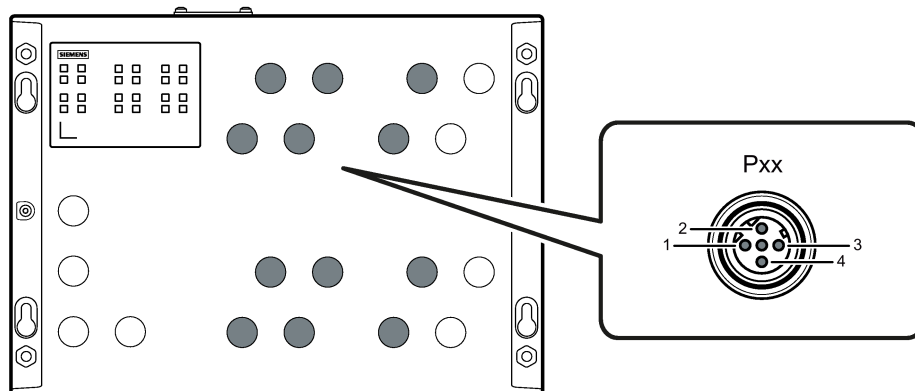

Pin number	Assignment
1	TD+
2	RD+
3	TD-
4	RD-

Gigabit Ethernet

For connection to Industrial Ethernet at 10/100/1000 Mbps, the device has the following M12 interfaces: X-coded, 8-pin, female.

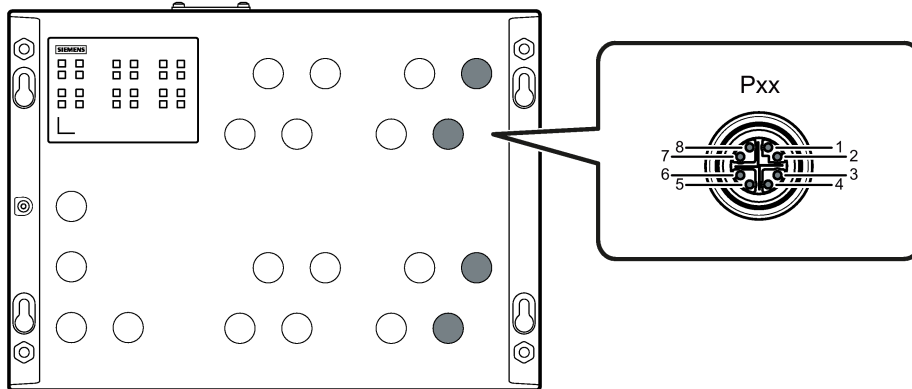

Pin number	Assignment
1	D0+
2	D0-
3	D1+
4	D1-
5	D3+
6	D3-
7	D2-
8	D2+

Connecting an Ethernet port

1. Connect the plug and socket. Make sure that they lock in place correctly.
2. Tighten the knurled screw (torque 1 Nm).

To allow an orderly cable outlet, you can arrange the angled M12 plug as follows:

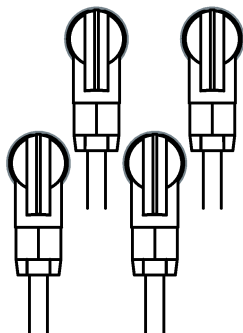

Ring ports

When shipped the ring ports are marked by a label. The labels are only clipped on and you can remove them if necessary.

IE FC M12 PLUG PRO

The IE FC M12 Plug PRO has a high degree of protection (IP65/67) and is suitable for connecting to Industrial Ethernet, see the section "Product overview (Page 17)".

MDI / MDI-X autocrossover function

With the MDI/MDI-X autocrossover function, the send and receive contacts of an Ethernet port are assigned automatically. The assignment depends on the cable with which the communications partner is connected. This means that it does not matter whether the port is connected using a patch cable or crossover cable. This prevents malfunctions resulting from mismatching send and receive wires. This makes installation much easier for the user.

Note

Formation of loops

Please note that the direct connection of two ports on the switch or accidental connection over several switches causes an illegal loop. Such a loop can lead to network overload and network failures.

Autonegotiation

Autonegotiation means the automatic detection/negotiation of the transmission rate and the operating mode of ports at the opposite end. This makes it possible to configure different devices automatically.

Two components connected to a link segment can exchange information about the transfer and can adapt their settings to each other. The mode with the highest possible speed is set.

Note

- If a port is set permanently to full duplex, the connected partner port must also be set to full duplex.
 - If a port operating in the "Auto negotiation" mode is connected to a partner port that is not operating in the "Auto negotiation" mode, the partner port setting must be fixed.
 - Devices not supporting "Auto negotiation" must be set permanently to 100 Mbps or 10 Mbps half duplex.
 - If you disable the "Auto negotiation" function, the "MDI/MDI-X autocrossover" function remains active.
-

4.3 24 VDC power supply

Notes on the power supply

 WARNING
Incorrect power supply You do not need to fuse the supply cable if you only use power sources with a limited power source (LPS) or power sources according to NEC Class 2 for the power supply of the devices. If the device is connected to a redundant power supply (two separate power supplies), both must meet these requirements. If you do not use power sources with a limited power source (LPS) or power sources according to NEC Class 2 for the power supply of the devices, you need to fuse the power sources externally, see the section "Safety when connecting up (Page 51)". Never operate the device with AC voltage or DC voltage higher than 32 V DC.

 CAUTION
Damage to the device due to overvoltage The connector of the external power supply is not protected against strong electromagnetic pulses that can, for example, result from lightning strikes or switching large loads. One of the tests used to attest the immunity of devices of the IE switches SCALANCE XP-200 to electromagnetic interference was the "surge immunity test" according to EN61000-4-5. This test requires overvoltage protection for the power supply lines. A suitable device is, for example, the Dehn Blitzductor BVT AVD 24, article number 918 422 or a comparable protective element. Manufacturer: DEHN+SOEHNE GmbH+Co.KG, Hans-Dehn-Str.1, Postfach 1640, D92306 Neumarkt, Germany Operate the SCALANCE XP-200 with suitable overvoltage protection.

Information on the power supply

- To connect to the power supply, the device has two M12 interfaces: A-coded, 4-pin, male.
- The power supply can be connected redundantly. Both inputs are isolated. There is no distribution of load. The power supply unit with the higher output voltage supplies the device alone.
- The power supply is connected over a high resistance with the enclosure to allow an ungrounded set up. The two power inputs are non-floating.
- To connect the power supply, use a copper cable of category 24 AWG or a cable with a cross-section $\geq 0.25 \text{ mm}^2$.
- To connect the functional ground, use a copper cable of category 20 AWG or a cable with a cross-section $\geq 0.75 \text{ mm}^2$.

Position and assignment

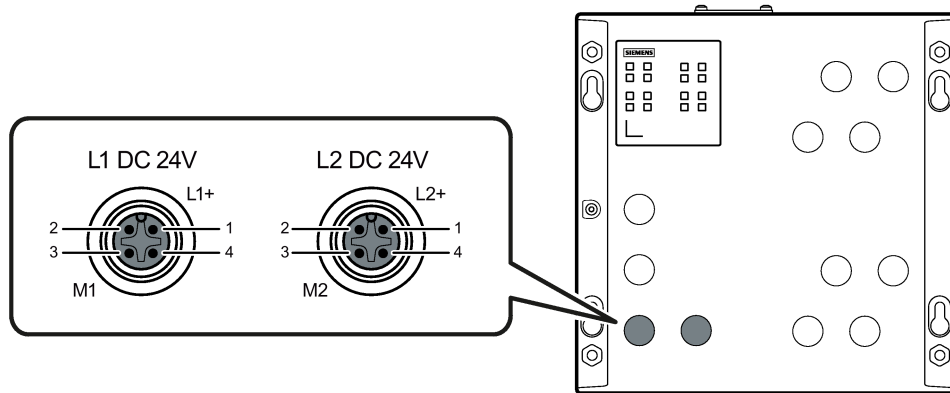

Figure 4-1 Position of the power supply, for example on the SCALANCE XP208

Pin number	Contact	Assignment
1	L1+	24 VDC
3	M1	Ground
1	L2+	24 VDC
3	M2	Ground

Connecting/disconnecting the power supply

NOTICE

Turn off the power supply before you insert or remove the plug of the power supply.

1. Connect the plug and socket. Make sure that they lock in place correctly.
2. Tighten the knurled screw (torque 1 Nm).

M12 Power T-Tap

To connect several to a power supply so that they are cascading, you can use an M12 Power T-Tap, see the section "Product overview (Page 17)".

The M12 Power T-Tap has two M12 sockets and one M12 plug.

Note

The M12 Power T-Tap has not been released for PoE power supply.

Note

The M12 Power T-Tap is only released for ambient temperatures from -25 °C to +85 °C. In the specified temperature range, you can load the M12 Power T-Tap with up to 2 A.

4.4 54 VDC power supply

Notes on the power supply



WARNING

Incorrect power supply

Never operate the PoE variants of the device with AC voltage or DC voltage higher than 60 VDC.

Information on the power supply

- Make sure that among other things the external power supply unit meets the following basic requirements:
 - The output voltage (PoE voltage) is a safety extra-low voltage (SELV).
 - The output voltage (PoE voltage) meets the isolation requirements according to IEEE 802.3at (in other words 1500 VAC or 2250 VDC) to ground, to touchable conductive parts and (if they exist) other secondary voltages.
 - Fuse the output voltage (PoE voltage) externally, see the section "Safety when connecting up (Page 51)".
- Select a suitable power of the external power supply unit, so that the power supply to the power consumers is ensured, see the section "Power over Ethernet (PoE) (Page 41)".
- For the cable supplying the power supply, use a cable with a length of max. 3 m.
- To connect the power supply, use a copper cable of category 18 AWG or a cable with a cross-section $\geq 0.75 \text{ mm}^2$, see e.g. the section "Product overview (Page 17)".
- To connect to the power supply, the device has two M12 interfaces: A-coded, 4-pin, male.
- The power supply can be connected redundantly. Both inputs are isolated. There is no distribution of load. The power supply unit with the higher output voltage supplies the device alone.
- The power supply is connected over a high resistance with the enclosure to allow an ungrounded set up. The two power inputs are non-floating.
- To connect the functional ground, use a copper cable of category 18 AWG or a cable with a cross-section $\geq 0.75 \text{ mm}^2$.

Position and assignment

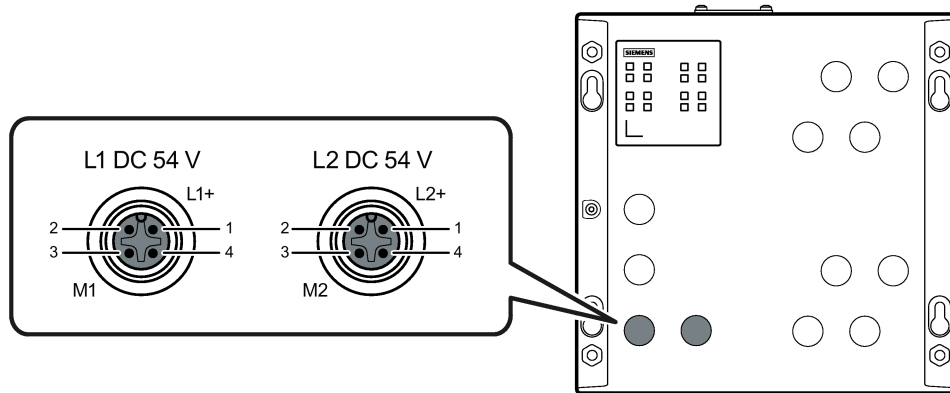

Figure 4-2 Position of the power supply, for example on the SCALANCE XP208PoE EEC

Pin number	Contact	Assignment
1	L1+	54 VDC
3	M1	Ground
1	L2+	54 VDC
3	M2	Ground

Connecting/disconnecting the power supply

NOTICE

Turn off the power supply before you insert or remove the plug of the power supply.

1. Connect the plug and socket. Make sure that they lock in place correctly.
2. Tighten the knurled screw (torque 1 Nm).

Note

Restriction of the power consumers

To supply Poe consumers of type 2 according to the standard, the power supply must provide an output voltage in the range 52 - 57 VDC.

4.5 Signaling contact

Information on the signaling contact

- To connect the signaling contact, the device has an M12 interface: B-coded, 5-pin, male.
- The signaling contact is a floating switch that signals error statuses by opening the contact.
The signaling contact must be operated within the range of the operating voltage. If an error/fault occurs, the signaling contact opens. In normal operation, the signaling contact is closed.
- To connect the signaling contact, use a copper cable of category 24 AWG or a cable with a cross-section of $\geq 0.25 \text{ mm}^2$, see e.g. the section "Product overview (Page 17)".

NOTICE
Damage due to voltage being too high
You can load the signaling contact with the operating voltage of the device and a maximum of 100 mA.
Higher voltages or currents can damage the device.

Position and assignment

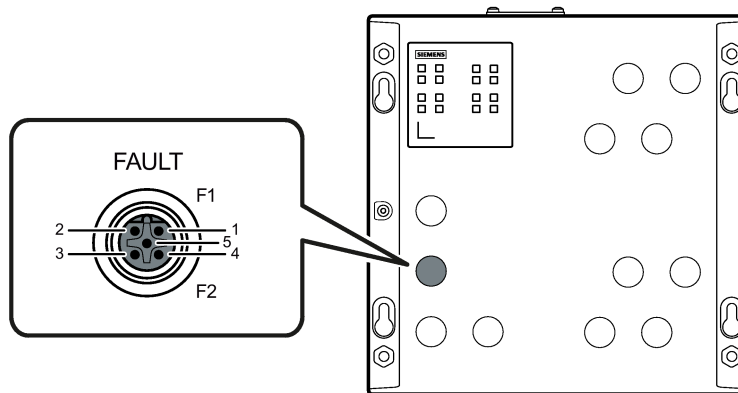

Figure 4-3 Position of the signaling contact, for example on the SCALANCE XP208

Pin number	Contact	Assignment
1	F1	Fault contact 1
4	F2	Fault contact 2

Signaling faults

- The signaling of errors by the signaling contact is synchronized with the fault LED "F", see section "F" LED (Page 29).
All errors that the fault LED "F" indicates (freely configurable) are also signaled by the signaling contact.
- If an internal fault occurs, the fault LED "F" lights up and the signaling contact opens.
- If you connect a communications node to an unmonitored port or disconnect it, this does not cause an error message.
- The signaling contact remains open until one of the following events occurs:
 - The problem is eliminated.
 - The current status is entered in the fault mask as the new desired status.

Connecting the signaling contact

1. Connect the plug and socket. Make sure that they lock in place correctly.
2. Tighten the knurled screw (torque 1 Nm).

4.6 Serial interface

Information on the serial interface

- To connect the serial interface, the device has an M12 interface: A-coded, 5-pin, female.
- Via the serial interface, you can access the CLI of the device directly via an RS-232 connection (115200 8N1) without assigning an IP address.
- Access to the device is also possible independent of the Ethernet ports.
- To connect the serial interface to the PC, you require a cable with an M12 plug and 9-pin D-sub female connector. You can order the connecting cable for the serial interface as an accessory.
- When it ships, the cover for the serial interface is secured to the housing see "Device views (Page 24)".

Position and assignment

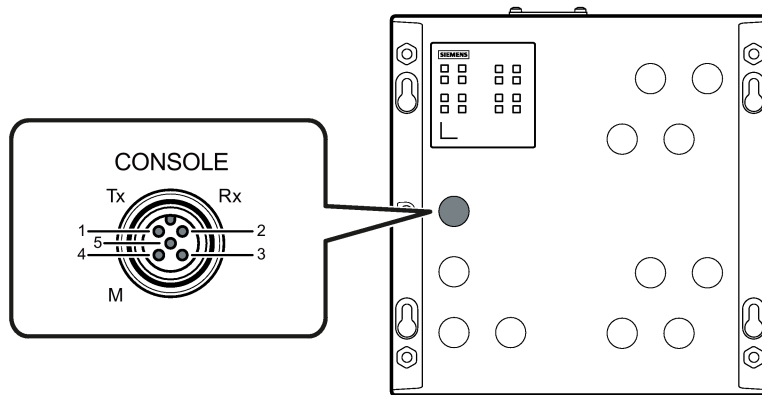

Figure 4-4 Position and pin assignment of the serial interface, for example on the SCALANCE XP208

Pin number	Assignment
1	TD (Transmit Data)
2	RD (Receive Data)
3	internal use only (do not connect)
4	SG (Signal Ground)
5	internal use only (do not connect)

Assignment of the terminal block

The connecting cable listed in the "Accessories" section has the following pin assignment:

Pin number	Pin assignment of the M12 plug	Pin assignment of the D-sub female connector
1	TD (Transmit Data)	-
2	RD (Receive Data)	RD (Receive Data)
3	-	TD (Transmit Data)
4	SG (Signal Ground)	-
5	-	SG (Signal Ground)
6		-
7		-
8		-
9		-

Connecting the serial interface

1. Connect the plug and socket. Make sure that they lock in place correctly.
2. Tighten the knurled screw (torque 1 Nm).

4.7 Functional ground

EMC disturbances are diverted to ground via the functional ground. This ensures the immunity of the data transmission.

The functional ground must be implemented with low impedance. The connection of the functional ground must be established directly on the mounting plate or the DIN rail terminal.

The grounding screw is identified by the following symbol for the functional ground .

Protective earth/functional ground

The connection of the reference potential surface with the protective circuit is normally in the cabinet close to the power feed-in. This ground conducts fault currents to ground safely and according to DIN/VDE 0100 is a protective ground to protect people, animals and property from too high contact voltages.

Apart from the protective ground, there is functional grounding in the cabinet. According to EN60204-1 (DIN/VDE 0113 T1) operational electrical circuits must be grounded. The chassis (0 V) is grounded at one defined point. Here, once again the grounding is implemented with the lowest leakage resistance to ground in the vicinity of the power feed-in.

With automation components, functional ground also ensures interference-free operation of a controller. Via the functional ground, interference currents coupled in via the connecting cables are discharged to ground.

Position

The functional ground is established via a grounding screw.

The connector for the grounding cable is on the front of the housing.

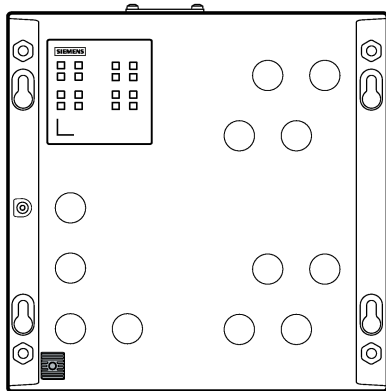
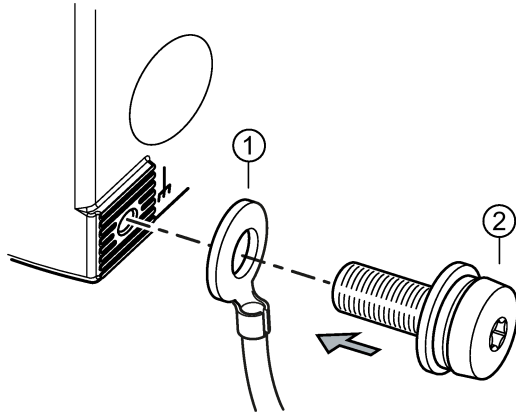

Figure 4-5 Position of the grounding screw on the SCALANCE XP-200

Connecting up functional ground



- ① Grounding terminal with cable
- ② Screw (M4 thread) with spring washer and washer

Follow the steps below to connect the functional ground:

1. Put the grounding terminal ①, and the bolt ② together as shown in the drawing.
2. Screw in the bolt ② with a maximum tightening torque of 1.5 Nm.

Upkeep and maintenance

5.1 Downloading new firmware using TFTP without WBM and CLI

Firmware

The firmware is signed and encrypted. This ensures that only firmware created by Siemens can be downloaded to the device.

Pressing the "RESET" button

To load new firmware, you require the "RESET" button. When pressing the button, remember the information in the section "RESET button (Page 33)".

Procedure with Microsoft Windows

Using TFTP, you can supply a device with new firmware even when it cannot be reached using WBM or CLI. This section explains the procedure based on the example of Microsoft Windows.

Follow the steps below to load new firmware using TFTP:

1. Turn off the power to the device.
2. Press the button and reconnect the power supply to the device while holding down the button.
3. Hold down the button until the red fault LED "F" starts to flash.
4. Release the button as long as the red error LED is still flashing..

Note

This time only lasts a few seconds.

The bootloader of the device waits in this status for a new firmware file that you can download by TFTP.

5. Connect a PC to port 0.1 via an Ethernet cable.
6. Assign an IP address to the device using DHCP or the Primary Setup Tool.

5.1 Downloading new firmware using TFTP without WBM and CLI

7. Open a Windows command prompt and change to the directory where the file with the new firmware is located and then execute the following command :

```
tftp -i <IP address> put <firmware file>
```

Note

You can enable TFTP in Microsoft Windows as follows:

"Control Panel" > "Programs and Features" > "Turn Windows features on or off" > "TFTP Client".

8. Once the firmware has been transferred completely to the device and validated, there is an automatic restart on the device. This may take several minutes.

5.2 Restoring the factory settings

NOTICE
Previous settings If you reset, all the settings you have made will be overwritten by factory defaults.

NOTICE
Inadvertent reset An inadvertent reset can cause disturbances and failures in the configured network with further consequences.

With the "RESET" button

Requirement

The device is in the startup phase.

NOTICE
Reset despite disabled "RESET button" Using the "RESET" button, you can always reset the device parameters to the factory settings during the startup phase of the device. This also applies if the "Reset to Factory Defaults" function was disabled in the configuration. This allows you to reset the device to the factory defaults in an emergency. If the function has been disabled with the configuration, it is only disabled on completion of the startup phase.

Procedure

When pressing the button, remember the information in the section "RESET button (Page 33)".

To reset the device to the factory defaults during the startup phase, follow the steps below:

1. Turn off the power to the device.
2. Loosen the screws of the cover.
3. Remove the cover.
4. Press the "RESET" button and reconnect the power supply to the device while holding down the button.
5. Hold down the button until the red error LED "F" stops flashing after approximately 20 seconds and is permanently lit.

5.2 Restoring the factory settings

6. Release the button and wait until the fault LED "F" goes off.

The device starts automatically with the factory settings.

7. Close the cover (tightening torque 0.8 Nm), to ensure that the device is closed and water and dust proof.

Restoring the factory defaults during operation

You can reset the device to the factory defaults during operation, see section "RESET button (Page 33)".

With the Primary Setup Tool

Follow the steps below to reset the device parameters to the factory defaults with the Primary Setup Tool.

1. Select the device whose parameters you want to reset.
2. Click on the menu item "Reset" in the "Module" tab.
3. Confirm the prompt with "OK".

During configuration

You will find detailed information on resetting the device parameters using the WBM and CLI in the configuration manuals see also section "Introduction (Page 3)":

- SCALANCE XB-200/XP 200 Web Based Management, section "Restart"
- SCALANCE XB-200/XP-200 Command Line Interface, section "Reset and Defaults"

Technical specifications

6.1 Technical specifications SCALANCE XP208 and SCALANCE XP208EEC

The following technical specifications apply to the following devices:

- SCALANCE XP208
- SCALANCE XP208EEC

Technical specifications		
Attachment to Industrial Ethernet		
	Quantity	8
	Connector	M12 socket
	Properties	D-coded, half/full duplex, MDI-X pinning
	Transmission speed	10 / 100 Mbps
Diagnostics interface		
Serial interface	Quantity	1
	Connector	M12 socket
Electrical data		
Power supply	Rated voltage	24 VDC
	Voltage range	19.2 to 28.8 VDC Safety Extra Low Voltage
	Design	M12 socket, 4-pin
	Cable cross-section	≥ 0.25 mm ² (24 AWG)
	Property	Implemented redundantly
Current consumption	at 24 VDC	200 mA
Effective power loss	at 24 VDC	4.8 W
Fusing		5 A / at least 60 V Or power supply with LPS or NEC class 2
Permitted ambient conditions		
Ambient temperature	During operation up to 2000 m	-40 °C to +70 °C ¹⁾
	During storage	-40 °C to +70 °C
	During transportation	-40 °C to +70 °C
Relative humidity	During operation at 25 °C	≤ 95 % no condensation
Housing, dimensions and weight		
Design	compact	
Housing material	Aluminum	

Technical specifications

6.1 Technical specifications SCALANCE XP208 and SCALANCE XP208EEC

Technical specifications	
Degree of protection	IP 65/67
Dimensions (W x H x D)	200 x 200 x 49 mm (57 mm incl. protective caps)
Weight	1800 g
Installation options	<ul style="list-style-type: none">• Wall mounting• Back wall mounting• Rack mounting
Mean time between failure (MTBF)	
MTBF (EN/IEC 61709; 40 °C)	> 77 years

1) EEC variants with EN 50155 support -40 °C ... +85 °C for 10 minutes

6.2 Technical specifications of the SCALANCE XP208PoE EEC

The following technical specifications apply to the SCALANCE XP208PoE EEC.

Technical specifications		
Attachment to Industrial Ethernet		
	Quantity	8
	Connector	M12 socket
	Properties	D-coded, half/full duplex; MDI-X pin assignment, P5 - P8 with Power over Ethernet
	Transmission speed	10 / 100 Mbps
Diagnostics interface		
Serial interface	Quantity	1
	Connector	M12 socket
Electrical data		
Power supply	Rated voltage	54 VDC
	Voltage range with PoE consumers type 1	46 to 57 VDC Safety Extra Low Voltage type 1
	Voltage range with PoE consumers type 2	52 to 57 VDC Safety Extra Low Voltage type 2
	Design	M12 socket, 4-pin
	Cable cross-section	≥ 0.75 mm ² (18 AWG)
	Property	Implemented redundantly
Current consumption	At 54 VDC without PoE load	110 mA
	At 54 VDC with max. PoE load	2500 mA
Effective power loss	At 54 VDC	6 W
	At 54 VDC in PoE operation	9 W
Fusing		5 A / at least 60 V
PoE power per device	At 54 VDC	120 W
Permitted ambient conditions		
Ambient temperature	During operation up to 2000 m	-40 °C to +70 °C ¹⁾
	During storage	-40 °C to +70 °C
	During transportation	-40 °C to +70 °C
Relative humidity	During operation at 25 °C	≤ 95 % no condensation
Housing, dimensions and weight		
Design	compact	
Housing material	Aluminum	
Degree of protection	IP 65/67	
Dimensions (W x H x D)	200 x 200 x 49 mm (57 mm incl. protective caps)	
Weight	1800 g	

Technical specifications

6.2 Technical specifications of the SCALANCE XP208PoE EEC

Technical specifications

- Installation options
- Wall mounting
 - Back wall mounting
 - Rack mounting
-

Mean time between failure (MTBF)

MTBF (EN/IEC 61709; 40 °C) > 55 years

¹⁾ EEC variants with EN 50155 support -40 °C ... +85 °C for 10 minutes

6.3 Technical specifications SCALANCE XP216 and SCALANCE XP216EEC

The following technical specifications apply to the following devices:

- SCALANCE XP216
- SCALANCE XP216EEC

Technical specifications		
Attachment to Industrial Ethernet		
	Quantity	16
	Connector	M12 socket
	Properties	D-/X-coded, half/full duplex, MDI-X pin assignment
	Transmission speed	<ul style="list-style-type: none"> • P1 - P8, P9, P11, P13 and P15 • 10 / 100 Mbps • P10, P12, P14 and P16 • 10 / 100/ 1000 Mbps
Diagnostics interface		
Serial interface	Quantity	1
	Connector	M12 socket
Electrical data		
Power supply	Rated voltage	24 VDC
	Voltage range	19.2 to 28.8 VDC Safety Extra Low Voltage
	Design	M12 socket, 4-pin
	Cable cross-section	≥ 0.25 mm ² (24 AWG)
	Property	Implemented redundantly
Current consumption	at 24 VDC	400 mA
Effective power loss	at 24 VDC	9.6 W
Fusing		5 A / at least 60 V Or power supply with LPS or NEC class 2
Permitted ambient conditions		
Ambient temperature	During operation up to 2000 m	-40 °C to +70 °C ¹⁾
	During storage	-40 °C to +70 °C
	During transportation	-40 °C to +70 °C
Relative humidity	During operation at 25 °C	≤ 95 % no condensation
Housing, dimensions and weight		
Design	compact	
Housing material	Aluminum	
Degree of protection	IP 65/67	
Dimensions (W x H x D)	200 x 280 x 49 mm (57 mm incl. protective caps)	
Weight	2500 g	

Technical specifications

- Installation options
- Wall mounting
 - Back wall mounting
 - Rack mounting
-

Mean time between failure (MTBF)

MTBF (EN/IEC 61709; 40 °C) > 48 years

¹⁾ EEC variants with EN 50155 support -40 °C ... +85 °C for 10 minutes

6.4 Technical specifications of the SCALANCE XP216PoE EEC

The following technical specifications apply to the SCALANCE XP216PoE EEC.

Technical specifications		
Attachment to Industrial Ethernet		
	Quantity	16
	Connector	M12 socket
	Properties	D-/X-coded, half/full duplex; MDI-X pin assignment, P5 - P8 and P13 - P16 with Power over Ethernet
	Transmission speed	<ul style="list-style-type: none"> • P1 - P8, P9, P11, P13 and P15 • 10 / 100 Mbps • P10, P12, P14 and P16 • 10 / 100/ 1000 Mbps
Diagnostics interface		
Serial interface	Quantity	1
	Connector	M12 socket
Electrical data		
Power supply	Rated voltage	54 VDC
	Voltage range with PoE consumers type 1	46 to 57 VDC Safety Extra Low Voltage
	Voltage range with PoE consumers type 2	52 to 57 VDC Safety Extra Low Voltage
	Design	M12 socket, 4-pin
	Cable cross-section	≥ 0.75 mm ² (18 AWG)
	Property	Implemented redundantly
Current consumption	At 54 VDC without PoE load	180 mA
	At 54 VDC with max. PoE load	2500 mA
Effective power loss	At 54 VDC	10 W
	At 54 VDC in PoE operation	13 W
Fusing		5 A / at least 60 V
PoE power per device	At 54 VDC	120 W
Permitted ambient conditions		
Ambient temperature	During operation up to 2000 m	-40 °C to +70 °C ¹⁾
	During storage	-40 °C to +70 °C
	During transportation	-40 °C to +70 °C
Relative humidity	During operation at 25 °C	≤ 95 % no condensation
Housing, dimensions and weight		
Design		compact
Housing material		Aluminum
Degree of protection		IP 65/67
Dimensions (W x H x D)		200 x 280 x 49 mm (57 mm incl. protective caps)
Weight		2500 g

6.5 Cable lengths

Technical specifications

- | | |
|----------------------|--|
| Installation options | <ul style="list-style-type: none">• Wall mounting• Back wall mounting• Rack mounting |
|----------------------|--|

Mean time between failure (MTBF)

MTBF (EN/IEC 61709; 40 °C)	> 35 years
----------------------------	------------

1) EEC variants with EN 50155 support -40 °C ... +85 °C for 10 minutes

6.5 Cable lengths

The following technical specifications apply to the following devices:

- SCALANCE XP208
- SCALANCE XP208EEC
- SCALANCE XP208PoE EEC
- SCALANCE XP216
- SCALANCE XP216EEC
- SCALANCE XP216PoE EEC

Cable	Permitted cable length
IE TP torsion cable	0 to 45 m
with IE FC Outlet RJ-45 + 10 m TP cord	+ 10 m TP cord
IE TP torsion cable	0 to 55 m
with IE FC RJ-45 Plug 180	
IE FC TP Marine / Trailing / Flexible cable	0 to 75 m
with IE FC Outlet RJ-45 + 10 m TP cord	+ 10 m TP cord
IE FC TP Marine / Trailing / Flexible cable	0 to 85 m
with IE FC RJ-45 Plug 180	
IE FC TP standard cable	0 to 90 m
with IE FC Outlet RJ-45 + 10 m TP cord	+ 10 m TP cord
IE FC TP standard cable	0 to 100 m
with IE FC RJ-45 Plug 180	

6.6 Switching properties

The following technical specifications apply to the following devices:

- SCALANCE XP208
- SCALANCE XP208EEC
- SCALANCE XP208PoE EEC
- SCALANCE XP216
- SCALANCE XP216EEC
- SCALANCE XP216PoE EEC

Switching properties		
Maximum frame size	1632	
Aging time	Can be configured (default value: 40 seconds)	
Max. number of learnable addresses	8192	
Switching technique	Store and forward	
Latency	10 microseconds	
Full wire speed switching:		
	Number of frames per second (at 100 Mbps)	Frame length
	148810	64 bytes
	84459	128 bytes
	45290	256 bytes
	23496	512 bytes
	11973	1024 bytes
	9615	1280 bytes
	8127	1518 bytes

Note

The number of SCALANCE XP-200 modules connected in a line influences the frame delay. When a frame passes through the IE switch, this is delayed by the store-and-forward function of the SCALANCE XP-200 by 10-130 microseconds (at 100 Mbps).

Dimension drawings

Note

Dimensions are specified in mm.

Front view of the SCALANCE XP208

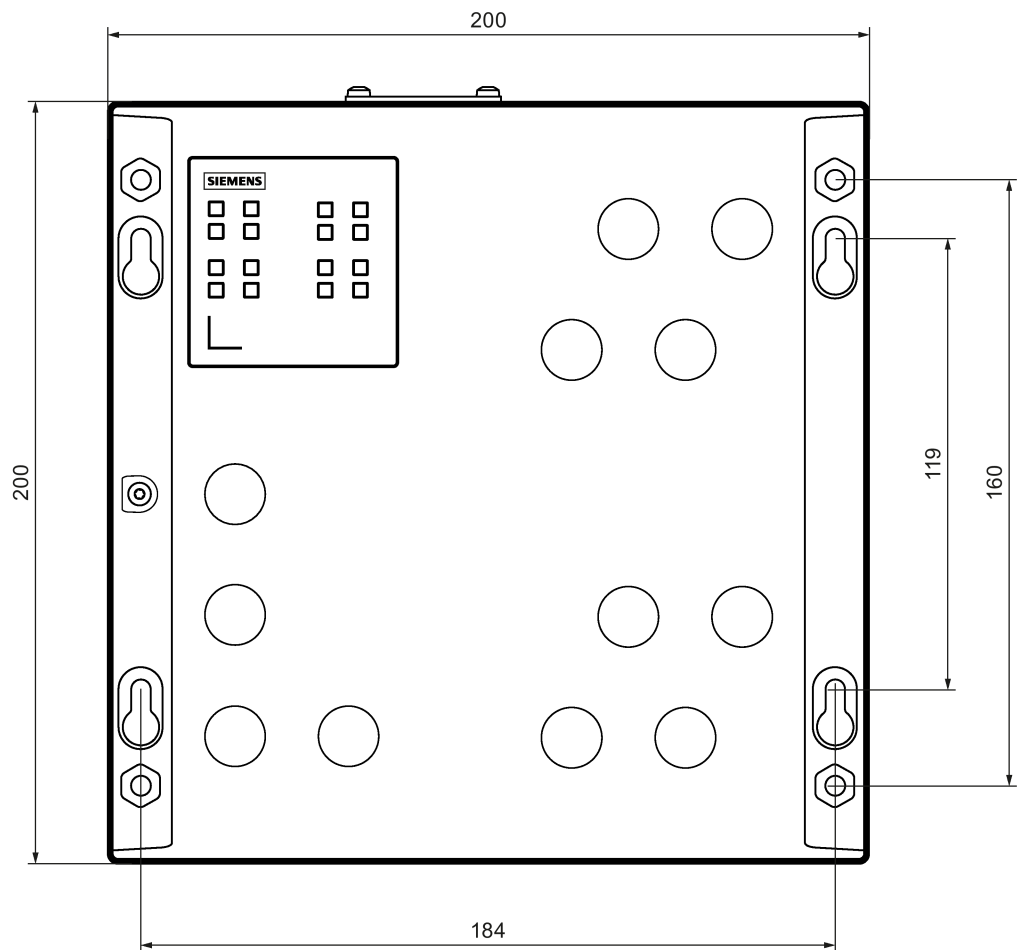

Figure 7-1 Width, height and dimensions for wall mounting

Front view of the SCALANCE XP216

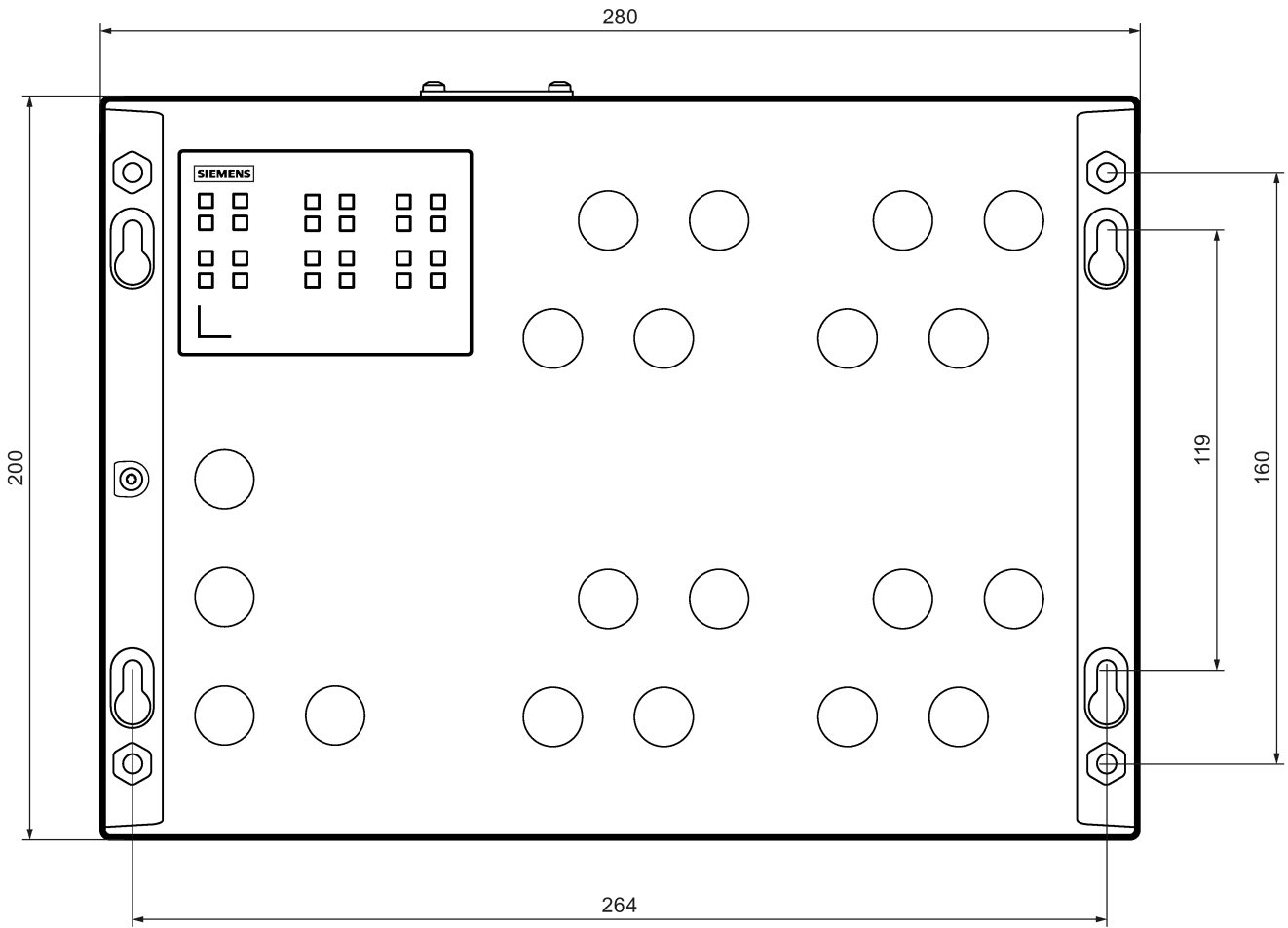

Figure 7-2 Width, height and dimensions for wall mounting

Side view of the SCALANCE XP-200

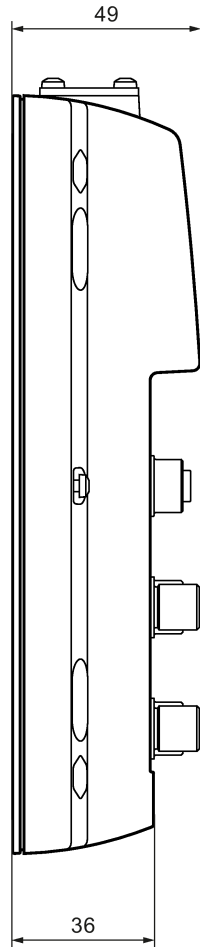

Figure 7-3 Depth

Approvals

The SIMATIC NET products described in these Operating Instructions have the approvals listed below.

Note**Issued approvals on the type plate of the device**

The specified approvals apply only when the corresponding mark is printed on the product. You can check which of the following approvals have been granted for your product by the markings on the type plate.

Current approvals on the Internet

You will find the current approvals for the product on the Internet pages of Siemens Industry Online Support (<http://support.automation.siemens.com/WW/view/en/33118389/134200>).

Installation guidelines

The devices meet the requirements if you adhere to the installation and safety instructions contained in this documentation and in the following documentation when installing and operating the devices.

- "Industrial Ethernet / PROFINET Industrial Ethernet" System Manual
- "Industrial Ethernet / PROFINET - Passive network components" System Manual

You will find information on the system manuals in the section "Introduction (Page 3)", in "Further documentation".

- "EMC Installation Guidelines" configuration manual
60612658 (<http://support.automation.siemens.com/WW/view/en/60612658>)

 WARNING
--

Personal injury and property damage can occur
--

The installation of expansions that are not approved for SIMATIC NET products or their target systems may violate the requirements and regulations for safety and electromagnetic compatibility.
--

Only use expansions that are approved for the system.

Note

The test was performed with a device and a connected communications partner that also meets the requirements of the standards listed above.

When operating the device with a communications partner that does not comply with these standards, adherence to the corresponding values cannot be guaranteed.

EC declaration of conformity



The SIMATIC NET products described in these operating instructions meet the requirements and safety objectives of the following EC directives and comply with the harmonized European standards (EN) which are published in the official documentation of the European Union.

- **2014/34/EU (ATEX explosion protection directive)**

Directive of the European Parliament and the Council of 26 February 2014 on the approximation of the laws of the member states concerning equipment and protective systems intended for use in potentially explosive atmospheres, official journal of the EU L96, 29/03/2014, pages. 309-356

- **2014/30/EU (EMC)**

EMC directive of the European Parliament and of the Council of February 26, 2014 on the approximation of the laws of the member states relating to electromagnetic compatibility; official journal of the EU L96, 29/03/2014, pages. 79-106

- **2011/65/EU (RoHS)**

Directive of the European Parliament and of the Council of 8 June 2011 on the restriction of the use of certain hazardous substances in electrical and electronic equipment

You will find the EC declaration of conformity for these products on the Internet pages of Siemens Industry Online Support (<http://support.automation.siemens.com/WW/view/en/33118389/134200>).

The EC Declaration of Conformity is available for all responsible authorities at:

Siemens Aktiengesellschaft

Division Process Industries and Drives
Process Automation
DE-76181 Karlsruhe
Germany

ATEX (explosion protection directive)

 WARNING
<p>When using SIMATIC NET products in hazardous area zone 2, make absolutely sure that the associated conditions in the following document are adhered to:</p> <p>"SIMATIC NET Product Information Use of subassemblies/modules in a Zone 2 Hazardous Area".</p> <p>You will find this document</p> <ul style="list-style-type: none"> • on the data medium that ships with some devices. • on the Internet pages of Siemens Industry Online Support (http://support.automation.siemens.com/WW/view/en). <p>Enter the document identification number C234 as the search term.</p>

The SIMATIC NET products meet the requirements of the EC directive 94/9/EC "Equipment and Protective Devices for Use in Potentially Explosive Atmospheres". and as of 20.04.2016 the EC directive 2014/34/EU.

ATEX classification:

II 3 G Ex nA IIC T4 Gc

KEMA 07ATEX0145 X

The products meet the requirements of the following standards:

- EN 60079-15 (electrical apparatus for potentially explosive atmospheres; Type of protection "n")
- EN 60079-0 (Explosive atmospheres - Part 0: Equipment - General requirements)

You will find the current versions of the standards in the currently valid ATEX certificates.

ATEX - use in hazardous areas Zone 2 / Zone 22

This section contains important information on installation in hazardous areas Zone 2 / Zone 22

You will find the EC Type Examination Certificate with the approved products on the Internet with the following link: Service & Support

(<http://support.automation.siemens.com/WW/view/de/71748103>)

ATEX classification

II 3 G Ex nA IIC T4 Gc

II 3 D Ex tc IIIC T90°C Dc IP67

DEKRA 12 ATEX 0220 X

The products meet the requirements of the following standards:

- EN 60079-15: Electrical apparatus for explosive gas atmospheres, Part 15: Type of protection "n"
- EN 60079-31: Explosive atmospheres, Equipment dust ignition protection by enclosure "t"

⚠ WARNING

Risk of personal injury and damage to property.

In hazardous areas injury to persons and damage to property can occur, if you disconnect plug-in connections during operation.

In hazardous areas, turn of the power to the device before disconnecting plug-in connections.

Special conditions

1. Set up the devices so that the risk of mechanical hazards is low.
2. Keep to the technical specifications of the products, specified in the EC Type Examination Certificate:
 - Power supply SCALANCE XP-200
 - Input and output currents
 - Ambient temperatures
3. Do not connect or disconnect the M12 connectors for Ethernet when the power is on.
4. Use the following cables with even connector outlets to wire the different M12 interfaces:
 - Ethernet: SIEMENS, article number 6XV1 871-5T, 6XV1 870-8A, see section "Product overview (Page 17)"
 - Supply voltage: SIEMENS, article number 6XV1 801-5D, see section "Product overview (Page 17)"

The serial interface, the signaling contact and the M12 Power T-Tap are not approved for operation of the product in hazardous area Zone 2 / Zone 22.

5. Protect all M12 connectors against unauthorized opening, for example with locking clips. Suitable locking clips can be obtained from PHOENIX CONTACT ¹⁾, product designation SAC-M12-EXCLIP-F or SAC-M12-EXCLIP-M.

SAC-M12-EXCLIP-F

SAC-M12-EXCLIP-M



6. Close all unused M12 round sockets with sealing caps so that they cannot be removed with the hand. Suitable sealing caps:
 - M12 protective caps for sockets (torque: 0.6 Nm) see section "Product overview (Page 17)".
 - M12 protective caps for plugs (tightening torque: 1.3 Nm) can be obtained from PHOENIX CONTACT ¹⁾, product designation PROT-M12 FS-M - 1430488

¹⁾ PHOENIX CONTACT GmbH & Co. KG, Flachsmarktstr. 8, D-32825 D-Blomberg, Germany <http://www.phoenixcontact.com> (<http://www.phoenixcontact.com>)

IECEX

The SIMATIC NET products meet the requirements of explosion protection according to IECEX.

IECEX classification:

Ex nA IIC T4 Gc

DEK 14.0025X

The products meet the requirements of the following standards:

- IEC 60079-15 (Explosive atmospheres - Part 15: Equipment protection by type of protection "n")
- IEC 60079-0 (Explosive atmospheres - Part 0: Equipment - General requirements)

You will find the current versions of the standards in the currently valid IECEX certificates.

EMC directive (electromagnetic compatibility)

Until 19.04.2016 the SIMATIC NET products described in these operating instructions meet the requirements of the EC Directive:2004/108/EC "Electromagnetic Compatibility" (EMC directive) and as of 20.04.2016 the EC directive 2014/30/EU.

Field of application	Requirements	
	Emission	Immunity to interference
Industry	EN 61000-6-4	EN 61000-6-2

You will find the current versions of the standards in the currently valid EC declaration of conformity.

RoHS

The SIMATIC NET products described in these operating instructions meet the requirements of the EC directive 2011/65/EC for the restriction of the use of certain hazardous substances in electrical and electronic equipment:

Applied standard:

- EN 50581

Safety of electrical equipment

In the version put into circulation by Siemens AG, the SIMATIC NET products described in these Operating Instructions conform to the regulations of the following European directive:

- EN 60950-1
Information technology equipment - Safety - Part 1: General requirements

FM

The product meets the requirements of the standards:

- Factory Mutual Approval Standard Class Number 3611
- FM Hazardous (Classified) Location Electrical Equipment:
Non Incendive / Class I / Division 2 / Groups A,B,C,D / T4 and
Non Incendive / Class I / Zone 2 / Group IIC / T4

cULus approval for industrial control equipment

cULus Listed IND. CONT. EQ.

Underwriters Laboratories Inc. complying with

- UL 61010-2-201
- CAN/CSA-IEC 61010-2-201

Report no. E85972

cULus Approval for Information Technology Equipment

cULus Listed I. T. E.

Underwriters Laboratories Inc. complying with

- UL 60950-1 (Information Technology Equipment)
- CSA C22.2 No. 60950-1-03

Report no. E115352

cULus Approval Hazardous Location

cULus Listed I. T. E. FOR HAZ. LOC.

Underwriters Laboratories Inc. complying with

- UL 60950-1 (Information Technology Equipment)
- ANSI/ISA 12.12.01-2007
- CSA C22.2 No. 213-M1987

Approved for use in

Cl. 1, Div. 2, GP A, B, C, D T4

Cl. 1, Zone 2, GP IIC T4

Report no. E240480

E1

The device meets the requirements of the ECE R10 directive.

Test number 10 R - 057876

Railway approval

EEC variants meet the requirements of the standards:

- EN 50155 "Railway applications - Electronic equipment used on rolling stock"
- EN 45545 "Railway applications - Fire protection on railway vehicles"

RCM

The product meets the requirements of the AS/NZS 2064 standard (Class A).

MSIP 요구사항 - For Korea only

A급 기기(업무용 방송통신기자재)

이 기기는 업무용(A급) 전자파 적합기기로서 판매자 또는 사용자는 이 점을 주의하시기 바라며, 가정 외의 지역에서 사용하는 것을 목적으로 합니다.

Marking for the customs union



EAC (Eurasian Conformity)

Customs union of Russia, Belarus and Kazakhstan

Declaration of the conformity according to the technical regulations of the customs union (TR CU)

Mechanical stability (in operation)

Device	IEC 60068-2-27 shock	IEC 60068-2-6 vibration
	15 g, 11 ms duration 6 shocks per axis	10 - 58 Hz: 0.075 mm 85 - 150 Hz: 1 g 1 octave/min, 20 sweeps
SCALANCE XP208	•	•
SCALANCE XP208EEC	•	•
SCALANCE XP208PoE EEC	•	•
SCALANCE XP216	•	•
SCALANCE XP216EEC	•	•
SCALANCE XP216PoE EEC	•	•

Index

A

- Accessories, 19
- A-coded, 56, 58, 62
- Ambient temperature, 71, 73, 75, 77
- Article numbers, 17
- Attachment to Industrial Ethernet, 71, 73, 75, 77
- Autonegotiation, 55

B

- B-coded, 60
- Button, 67
 - Cover, 24, 25, 26, 27
 - Function, 33, 35
 - Overview, 24, 25, 26, 27
 - RESET, 24, 25, 26, 27, 33
 - SELECT/SET, 24, 25, 26, 27, 35

C

- Cable, 19
- CLI, 62
- Command Line Interface, 62
- Command Line Interface (CLI), 38, 67
- Components of the product, 18
- Configuration, 34
- Configuration manuals, 70
- Connecting up
 - Grounding, 64
- C-PLUG, 19
 - Configuration, 37
 - Cover, 24, 25, 26, 27, 39
 - Overview, 24, 25, 26, 27
 - Replacing, 39

D

- Data cable, 19
- Data line, 19
- Defining the fault mask, 36
- Dimensions, 71, 73, 75, 77
- Display mode, 29, 35

E

- E1, 90
- Electrical data, 71, 73, 75, 77
- Energy cable, 21
- Environmental conditions, 71, 73, 75, 77
- ESD directives, 7

F

- Factory defaults, 33, 33, 69
- Factory setting, 33
- Factory settings, 69
- Fast Ethernet
 - Connecting up, 53
 - Overview, 24, 25, 26, 27
- Fault mask, 36
- Fault/error status, 29
- Firmware, 29, 67
- Functional ground
 - Connecting up, 64

G

- Gigabit Ethernet
 - Connecting up, 54
 - Overview, 26, 27
- Glossary, 5
- Grounding, 64
 - Connecting up, 64
 - Overview, 24, 25, 26, 27
- Grounding point, 24, 25, 26, 27, 64

H

- Hexagonal nut
 - Installation, 48
 - Overview, 24, 25, 26, 27
- Housing, 71, 73, 75, 77

I

- IE FC M12 Plug PRO, 19
- Industrial Ethernet
 - Connecting up, 53

Installation, 71, 73, 75, 77
 Installation on a standard rail, 48
 Rack, 49
Installation on a standard rail, 48

K

Keyhole hang-up mechanism
 Installation, 49
 Overview, 24, 25, 26, 27

L

LED, 28
 Display, 28
 Overview, 24, 25, 26, 27, 28

M

M12 data plug-in connector, 19
M12 Power T-Tap, 22, 22, 57
MDI / MDI-X autocrossover, 55
MTBF, 72, 74, 76, 78

P

Permitted ambient conditions, 71, 73, 75, 77
PLUG, 37
PoE, 25, 27, 41
Power over Ethernet, 41
Power supply
 Connecting up, 56, 58
 Overview, 24, 25, 26, 27
Power supply unit, 21
Power T tap, 22, 57
Protective cap, 23
Protective caps, 18

R

Rack, 49
Redundancy manager, 36
Reset device, 33, 33, 69, 69
Reset to Factory Defaults, 34, 69

S

S7-300, 48

Safety notices, 51
 for installation, 45
 general, 11
 Use in hazardous areas, 11, 45, 51
 when connecting up, 51
SELECT/SET button, 30
Serial interface
 Connecting up, 62
 Cover, 24, 24, 25, 25, 26, 26, 27, 27, 62
 Overview, 24, 25, 26, 27
Signaling contact, 29
 Connecting up, 60
 Overview, 24, 25, 26, 27
SIMATIC NET glossary, 5
SIMATIC NET manual, 4
Spare parts, 23
Startup phase, 29, 34, 69
System manual, 4, 46, 85

W

Web Based Management (WBM), 38, 67
Weight, 71, 73, 75, 77