

SIEMENS

SIMATIC NET

Industrial Ethernet Switches SCALANCE X-300

Operating Instructions

Preface	
Safety instructions	1
Introduction	2
Network topologies	3
Description of the device	4
Installation	5
Connecting	6
Configuration, displays and display elements	7
Technical specifications	8
Approvals, certificates, standards	9
Accessories	10
Graphics	11
Appendix	A

Legal information

Warning notice system

This manual contains notices you have to observe in order to ensure your personal safety, as well as to prevent damage to property. The notices referring to your personal safety are highlighted in the manual by a safety alert symbol, notices referring only to property damage have no safety alert symbol. These notices shown below are graded according to the degree of danger.

DANGER

indicates that death or severe personal injury **will** result if proper precautions are not taken.

WARNING

indicates that death or severe personal injury **may** result if proper precautions are not taken.

CAUTION

indicates that minor personal injury can result if proper precautions are not taken.

NOTICE

indicates that property damage can result if proper precautions are not taken.

If more than one degree of danger is present, the warning notice representing the highest degree of danger will be used. A notice warning of injury to persons with a safety alert symbol may also include a warning relating to property damage.

Qualified Personnel

The product/system described in this documentation may be operated only by **personnel qualified** for the specific task in accordance with the relevant documentation, in particular its warning notices and safety instructions. Qualified personnel are those who, based on their training and experience, are capable of identifying risks and avoiding potential hazards when working with these products/systems.

Proper use of Siemens products

Note the following:

WARNING

Siemens products may only be used for the applications described in the catalog and in the relevant technical documentation. If products and components from other manufacturers are used, these must be recommended or approved by Siemens. Proper transport, storage, installation, assembly, commissioning, operation and maintenance are required to ensure that the products operate safely and without any problems. The permissible ambient conditions must be complied with. The information in the relevant documentation must be observed.

Trademarks

All names identified by ® are registered trademarks of Siemens AG. The remaining trademarks in this publication may be trademarks whose use by third parties for their own purposes could violate the rights of the owner.

Disclaimer of Liability

We have reviewed the contents of this publication to ensure consistency with the hardware and software described. Since variance cannot be precluded entirely, we cannot guarantee full consistency. However, the information in this publication is reviewed regularly and any necessary corrections are included in subsequent editions.

Preface

Purpose of the Operating Instructions

These Operating Instructions describe the design and functions of the compact and modular Industrial Ethernet Switches of the SCALANCE X-300 product line and support you during installation, commissioning, and troubleshooting on site.

Validity of the Operating Instructions

These Operating Instructions are valid for the following product groups of the SCALANCE X-300 product line, see also section Product overview (Page 27).

- X-300
- X-300M
- XR-300M
- X-300EEC
- XR-300M EEC
- X-300M PoE
- XR-300M PoE
- MM900 media modules
- SFP transceiver

Names of the devices in these operating instructions

Within the SCALANCE X-300 product line, there are product groups, devices and variants.

Classification	Description
Product line (X-300)	For all devices and variants of all product groups within the SCALANCE X-300 product line, the term "IE Switch X-300" is used.
Product group	For all devices and variants of a product group, only the product group is used.
Device	For a device, only the device name is used.
Variant	A variant of a device represents a particular design version. They are identified by a separate order number. When all variants of a device are meant in the text, "(all)" is often added after the device name.

Overview of the technical documentation of the IE Switches X-300

The technical documentation of the X-300 product line is divided into hardware and software and can be found in the following documents:

- **PH** - Configuration Manual (PDF)

The software is described in the configuration manual (PH) for both product lines X-300 and X-400.

- **BAK** - Operating Instructions (compact) on paper

The hardware of each product group is described in the Operating Instructions (compact) (BAK).

- **BA** - Operating Instructions (PDF)

The hardware for all product groups and general information can be found in the Operating Instructions (BA).

Contents	Product group	Type of document	Document identification number
Software description	All devices of the X-300 and X-400 product lines	PH X300/X400	C79000-G89000-C187
Hardware description	All devices of the X-300 product line	BA X-300	A5E01113043
	X-300	BAK X-300	A5E00982643A
	X-300M	BAK X-300M	A5E02630801A
	XR-300M	BAK XR-300M	A5E02661171A
	X-300EEC	BAK X-300 EEC	A5E02661176A
	XR-300M EEC	BAK XR-300M EEC	A5E02630809A
	X-300M PoE	BAK X-300M PoE	A5E02630810A
	XR-300M PoE	BAK XR-300M PoE	A5E02661178A
	MM900 (media modules)	BAK MM900	A5E02630805A
	SFP (transceivers)	BAK SFP Notices leaflet	A5E02630804A A5E02648904A

Further documentation

For help on configuration and diagnostics using Web-based management, the CLI command line interface, or SNMP, refer to the following documentation:

- Configuration Manual SCALANCE X-300 SCALANCE X-400

This configuration manual is available on the following media:

- On the supplied CD
- In 5 languages on the Internet on the pages of Siemens Automation Customer Support under the following entry ID:

19625108 (<http://support.automation.siemens.com/WW/view/en/19625108>)

- SIMATIC NET - Industrial Ethernet Network manual

This manual is available on the following media:

- On paper under order numbers:
 - English version: 6GK1 970-1BA10-0AA1
 - German version: 6GK1 970-1BA10-0AA0
- In German and English on the Internet on the pages of Siemens Automation Customer Support under the following entry ID:

27069465 (<http://support.automation.siemens.com/WW/view/en/27069465>)

If you have questions on the use of SIMATIC NET products, please contact your Siemens sales partner.

Standards and approvals

The devices of the SCALANCE X-300 product line meet the requirements for the CE mark. For more detailed information, refer to section Approvals, certificates, standards (Page 223).

Integration in STEP 7 projects

The current GSDML file must be used for integration in STEP 7 V5.4 SP5 projects. This applies to all products covered by these operating instructions.

You can obtain the relevant GSD file from the Internet at:

46183514 (<http://support.automation.siemens.com/WW/view/en/46183514>)

You will find the file for the firmware update V3.3.1 for X-300 under entry ID "46183538".

SIMATIC NET glossary

Explanations of many of the specialist terms used in this documentation can be found in the SIMATIC NET glossary.

You will find the SIMATIC NET glossary here:

- SIMATIC NET Manual Collection or product DVD

The DVD ships with certain SIMATIC NET products.

- On the Internet under the following address:

50305045 (<http://support.automation.siemens.com/WW/view/en/50305045>)

Security information

Siemens provides products and solutions with industrial security functions that support the secure operation of plants, solutions, machines, equipment and/or networks. They are important components in a holistic industrial security concept. With this in mind, Siemens' products and solutions undergo continuous development. Siemens recommends strongly that you regularly check for product updates.

For the secure operation of Siemens products and solutions, it is necessary to take suitable preventive action (e.g. cell protection concept) and integrate each component into a holistic, state-of-the-art industrial security concept. Third-party products that may be in use should also be considered. For more information about industrial security, visit <http://www.siemens.com/industrialsecurity>.

To stay informed about product updates as they occur, sign up for a product-specific newsletter. For more information, visit <http://support.automation.siemens.com>.

Table of contents

	Preface	3
1	Safety instructions.....	15
1.1	Important notes on using the device.....	15
1.2	PELV	17
1.3	Important notes on using the device in hazardous areas	18
1.4	Security recommendations	19
2	Introduction.....	25
2.1	Basics of Ethernet switching.....	25
2.2	Product overview	27
2.2.1	Type designations.....	27
2.2.2	Designs of the IE Switch X-300 devices	28
2.2.3	X-300 product group	29
2.2.4	Product group X-300M.....	30
2.2.5	Product group XR-300M	31
2.2.6	X-300EEC product group.....	31
2.2.7	XR-300M EEC product group	32
2.2.8	Product group X-300M PoE.....	33
2.2.9	Product group XR-300M PoE	33
2.2.10	SFP transceiver	34
2.2.11	MM900 media modules.....	35
3	Network topologies	39
3.1	Linear structure	39
3.2	Star/tree structure	39
3.3	Ring with redundancy manager	40
3.4	Redundant coupling of network segments.....	44
4	Description of the device.....	47
4.1	Compatibility of SCALANCE X-300	47
4.2	Product groups.....	49
4.2.1	X-300 product group	49
4.2.1.1	SCALANCE X304-2FE product characteristics	49
4.2.1.2	SCALANCE X306-1LD FE product characteristics	50
4.2.1.3	SCALANCE X307-3 product characteristics.....	51
4.2.1.4	SCALANCE X307-3LD product characteristics	52
4.2.1.5	SCALANCE X308-2LH product characteristics	53
4.2.1.6	SCALANCE X308-2LH+ product characteristics	54
4.2.1.7	SCALANCE X308-2 product characteristics.....	55
4.2.1.8	SCALANCE X308-2LD product characteristics	56
4.2.1.9	SCALANCE X310 product characteristics	57

4.2.1.10	SCALANCE X310FE product characteristics	58
4.2.1.11	SCALANCE X320-1FE product characteristics	59
4.2.1.12	SCALANCE X320-3LD FE product characteristics.....	60
4.2.2	Product group X-300M.....	61
4.2.3	Product group XR-300M	63
4.2.4	X-300EEC product group.....	65
4.2.4.1	Characteristics of the X-300EEC product group.....	65
4.2.5	XR-300M EEC product group	70
4.2.5.1	Product characteristics of the SCALANCE XR324-4M EEC	70
4.2.6	Product group X-300M PoE	71
4.2.6.1	SCALANCE X308-2M PoE product characteristics	71
4.2.7	Product group XR-300M PoE	73
4.2.7.1	SCALANCE XR324-4M PoE product characteristics	73
4.2.8	MM900 media modules.....	74
4.2.8.1	MM992-2CUC product characteristics	74
4.2.8.2	MM992-2CU product characteristics.....	75
4.2.8.3	MM992-2VD product characteristics.....	75
4.2.8.4	MM992-2M12 product characteristics.....	76
4.2.8.5	MM992-2SFP / MM992-2SFP (C) product properties	77
4.2.8.6	MM991-2 product characteristics.....	77
4.2.8.7	MM991-2FM product characteristics.....	78
4.2.8.8	MM991-2LD product characteristics	78
4.2.8.9	MM991-2 (SC) product characteristics	79
4.2.8.10	MM991-2LD (SC) product characteristics.....	79
4.2.8.11	MM991-2LH+ (SC) product characteristics.....	80
4.2.8.12	MM991-2P product characteristics	80
4.2.8.13	MM992-2 product characteristics.....	81
4.2.8.14	MM992-2LD product characteristics	82
4.2.8.15	MM992-2LH product characteristics	82
4.2.8.16	MM992-2LH+ product characteristics	83
4.2.8.17	MM992-2ELH product characteristics.....	83
4.2.8.18	General notes on MM900	83
4.2.9	SFP transceiver.....	85
4.2.9.1	SCALANCE SFP991-1 product characteristics	85
4.2.9.2	SCALANCE SFP991-1LD product characteristics.....	85
4.2.9.3	SCALANCE SFP991-1LH+ product characteristics	86
4.2.9.4	SCALANCE SFP992-1 product characteristics	86
4.2.9.5	SCALANCE SFP992-1LD product characteristics.....	86
4.2.9.6	SCALANCE SFP992-1LH product characteristics.....	87
4.2.9.7	SCALANCE SFP992-1LH+ product characteristics	87
4.2.9.8	SCALANCE SFP992-1ELH product characteristics	87
4.2.9.9	General notes on SFP	88
4.2.9.10	Supported wavelengths of the SFPs	88
4.3	Interfaces and signaling contact of the switches	89
4.3.1	Ethernet interfaces - electrical ports	89
4.3.1.1	10Base-T / 100Base-TX	89
4.3.1.2	1000Base-T.....	90
4.3.1.3	Power over Ethernet (PoE)	91
4.3.1.4	Ports of the X308-2M PoE	92
4.3.1.5	PoE ports	93
4.3.1.6	Isolation between the TP ports	93
4.3.2	Ethernet interfaces - optical ports	93

4.3.2.1	1000Base-SX.....	93
4.3.2.2	1000Base-LX / 100Base-FX.....	94
4.3.3	Signaling contact.....	95
4.4	C-PLUG (configuration plug).....	95
4.5	Components of the product.....	99
4.5.1	Components of the product.....	99
4.5.2	X-300M components of the product.....	99
4.5.3	Components of the XR-300M product.....	100
4.5.4	X-300EEC product components.....	101
4.5.5	Components of the XR-300M EEC product.....	101
4.5.6	Components of the X308-2M PoE product.....	102
4.5.7	Components of the XR-324-4M PoE product.....	103
4.5.8	Components shipped with the MM900 product.....	103
4.5.9	Components shipped with the SFP product.....	103
5	Installation.....	105
5.1	Overview of the methods of installation.....	106
5.2	Installing a switch.....	107
5.2.1	Installation on a DIN rail.....	107
5.2.2	Installation on a standard rail.....	108
5.2.3	Wall mounting.....	110
5.2.4	19" rack mounting.....	111
5.2.5	19" rack mounting - X-300EEC product group.....	115
5.2.6	19" rack mounting - XR-300M EEC product group.....	116
5.3	Inserting media modules and SFP transceivers.....	120
5.3.1	Installation and removal of media modules.....	120
5.3.2	SFP installation in SFP media module.....	124
6	Connecting.....	127
6.1	Wiring rules.....	127
6.2	Connecting the switch.....	127
6.3	Connecting media modules/SFPs.....	129
6.4	Connecting the grounding.....	130
6.4.1	Connecting the functional ground (XR-300M EEC).....	130
6.4.2	Grounding of the X-300EEC.....	130
6.5	Power supply.....	132
6.5.1	24 VDC power supply.....	132
6.5.1.1	24 VDC safety extra low voltage.....	132
6.5.1.2	24 VDC - product group X-300.....	133
6.5.1.3	12 / 24 VDC - product group X-300M.....	134
6.5.1.4	24 VDC - product group XR-300M.....	134
6.5.1.5	24 VDC - product group X-300EEC.....	134
6.5.1.6	24 VDC - product group X-300M PoE.....	135
6.5.1.7	24 VDC - XR-300M PoE product group.....	135
6.5.1.8	Connector for redundant power supply.....	135
6.5.1.9	Connecting a redundant power supply to the XR300-EEC.....	137
6.5.2	100 to 240 VAC power supply.....	139
6.5.2.1	100 ... 240 V - product group XR-300M.....	139

6.5.2.2	100 to 240 VAC - product group X-300EEC	139
6.5.2.3	100 to 240 VAC - XR-300M EEC product group	140
6.5.2.4	100 to 240 VAC XR-300M PoE product group	140
6.5.2.5	Fitting the connector for 100 to 240 V AC	140
6.5.2.6	Connecting the 100 to 240 VAC power supply	142
6.5.2.7	Connecting the power supply 100 to 240 VAC to X-300EEC / XR-300M EEC	142
6.5.2.8	Connecting the 100 to 240 V AC power supply with the XR-300M PoE	144
6.6	Signaling contact.....	145
6.6.1	24 VDC signaling contact.....	145
6.6.2	Signaling contact 100 to 240 VAC / 60 to 250 VDC (X-300EEC).....	146
7	Configuration, displays and display elements	147
7.1	Assignment of slot numbers.....	147
7.2	Show Location.....	148
7.3	XR-300 diagnostics port.....	148
7.4	The SET / SELECT button	149
7.5	LED display	151
8	Technical specifications	155
8.1	Overview of operating temperatures for SCALANCE X-300	155
8.2	X-300 technical specifications.....	156
8.2.1	Construction, installation and environmental conditions.....	157
8.2.2	Connectors and electrical data	158
8.2.3	Cable lengths	161
8.2.4	Other properties	163
8.3	X-300M technical specifications.....	164
8.3.1	Construction, installation and environmental conditions.....	164
8.3.2	Connectors and electrical data	166
8.3.3	Cable lengths	167
8.3.4	Other properties	168
8.4	XR-300M technical specifications	170
8.4.1	Construction, installation and environmental conditions.....	170
8.4.2	Connectors and electrical data	172
8.4.3	Cable lengths	173
8.4.4	Block architecture.....	174
8.4.5	Other properties	175
8.5	Technical specifications for X-300EEC.....	177
8.5.1	Construction, installation and environmental conditions.....	177
8.5.2	Connectors and electrical data	179
8.5.3	Cable lengths	181
8.5.4	Other properties	182
8.6	XR-300M EEC technical specifications	183
8.6.1	Construction, installation and environmental conditions.....	184
8.6.2	Connectors and electrical data	186
8.6.3	Cable lengths	188
8.6.4	Block architecture.....	189
8.6.5	Other properties	190

8.7	X-300M PoE technical specifications.....	191
8.7.1	Construction, installation and environmental conditions.....	191
8.7.2	Connectors and electrical data	193
8.7.3	Cable lengths	195
8.7.4	Other properties	196
8.8	XR-300M PoE technical specifications	197
8.8.1	Construction, installation and environmental conditions.....	198
8.8.2	Connectors and electrical data	200
8.8.3	Cable lengths	202
8.8.4	Block architecture	203
8.8.5	Other properties	204
8.9	MM900 technical specifications	205
8.9.1	Construction, installation and environmental conditions.....	205
8.9.2	Connectors and electrical data	208
8.9.3	Cable lengths	210
8.9.4	Other properties	214
8.10	SFP technical specifications	215
8.10.1	Construction, installation and environment.....	215
8.10.2	Connectors and electrical data	217
8.10.3	Cable lengths	220
8.10.4	Other properties	221
9	Approvals, certificates, standards.....	223
9.1	X-300 product group	223
9.1.1	X-300 approvals, certificates	223
9.1.2	X-300 type plate.....	227
9.1.3	SCALANCE X-300 declaration of conformity.....	227
9.1.4	X-300 FDA and IEC approvals	227
9.1.5	Overview of the X-300 approvals.....	228
9.1.6	X-300 mechanical stability (in operation).....	229
9.2	Product group X-300M.....	229
9.2.1	X-300M approvals, certificates	229
9.2.2	X-300M type plate.....	233
9.2.3	SCALANCE X-300 declaration of conformity.....	233
9.2.4	X-300M FDA and IEC approvals	234
9.2.5	Overview of X-300M approvals.....	234
9.2.6	X-300M mechanical stability (in operation).....	235
9.3	Product group XR-300M	235
9.3.1	XR-300M approvals, certificates	235
9.3.2	XR-300M type plate	240
9.3.3	SCALANCE X-300 declaration of conformity.....	240
9.3.4	XR-300M FDA and IEC approvals.....	241
9.3.5	Overview of XR-300M approvals	241
9.3.6	XR-300M mechanical stability (in operation)	242
9.4	X-300EEC product group.....	243
9.4.1	X-300EEC approvals and certificates	243
9.4.2	SCALANCE X-300 declaration of conformity.....	247
9.4.3	Overview of the approvals for the X-300EEC.....	248
9.4.4	X-300EEC mechanical stability (in operation)	248

9.5	XR-300M EEC product group	249
9.5.1	XR-300M EEC approvals, certificates	249
9.5.2	SCALANCE X-300 declaration of conformity	253
9.5.3	Overview of XR-300M EEC approvals	254
9.5.4	XR-300M EEC mechanical stability (in operation)	254
9.6	Product group X-300M PoE	255
9.6.1	X-300M PoE approvals, certificates	255
9.6.2	SCALANCE X-300 declaration of conformity	259
9.6.3	Overview of X-300M PoE approvals	259
9.6.4	X-300M PoE mechanical stability in operation	259
9.7	Product group XR-300M PoE	260
9.7.1	XR-300M PoE approvals, certificates	260
9.7.2	SCALANCE X-300 declaration of conformity	263
9.7.3	Overview of XR-300M PoE approvals	264
9.7.4	XR-300M PoE mechanical stability in operation	264
9.8	MM900 product group	265
9.8.1	MM900 approvals, certificates	265
9.8.1.1	ATEX (KEMA 07 ATEX0145 X)	267
9.8.2	MM900 declaration of conformity	270
9.8.3	Overview of the MM900 approvals	270
9.8.4	MM900 FDA and IEC approvals	272
9.9	Product group SFP	273
9.9.1	Approvals, certificates	273
9.9.2	SFP type plate	277
9.9.3	SFP declaration of conformity	277
9.9.4	SFP FDA and IEC approvals	278
9.9.5	Overview of the SFP approvals	278
9.9.6	SFP mechanical stability (in operation)	280
10	Accessories	281
10.1	Accessories	281
11	Graphics	283
11.1	Dimension drawing	283
11.2	X-300M dimension drawings	289
11.3	XR-300M dimension drawings	291
11.4	X-300EEC dimension drawings	294
11.5	XR-300M EEC dimension drawings	296
11.6	MM900 dimension drawings	302
11.7	SFP dimension drawings	305
11.8	X-300M PoE dimension drawings	306
11.9	XR-300M PoE dimension drawings	309
A	Appendix	311
A.1	TP port	311
A.2	The connector system M12/X coded according to IEC 61076-2-109	313

A.3	Fitting the IE FC RJ-45 Plug	314
A.4	Electrical tests (EEC devices).....	316
A.5	EMC-compatible installation of electrical Industrial Ethernet or PROFIBUS cabling	317
A.6	Equipotential bonding	318
Index		321



Safety instructions

1.1 Important notes on using the device

Safety notices on the use of the device

The following safety notices must be adhered to when setting up and operating the device and during all associated work such as installation, connecting up, replacing or opening the device.

General information

<p> WARNING</p> <p>Opening the device</p> <p>DO NOT OPEN WHEN ENERGIZED.</p>
<p> WARNING</p> <p>Safety extra low voltage (only devices with 24 VDC power supply)</p> <p>The equipment is designed for operation with Safety Extra-Low Voltage (SELV) by a Limited Power Source (LPS).</p> <p>This means that only SELV / LPS (Limited Power Source) complying with IEC 60950-1 / EN 60950-1 / VDE 0805-1 must be connected to the power supply terminals. The power supply unit for the equipment power supply must comply with NEC Class 2, as described by the National Electrical Code (r) (ANSI / NFPA 70).</p> <p>If the equipment is connected to a redundant power supply (two separate power supplies), both must meet these requirements.</p> <p>A power source that supplies safety extra low voltage combined with a following NEC Class 2 power limiter also meets the requirements according to IEC 60950-1 / EN 60950-1 / VDE 0805-1 or NEC Class 2. A suitable power limiter is for example the redundancy module SITOP PSE202U NEC Class 2 (article number 6EP1962-2BA00).</p>
<p> WARNING</p> <p>For use in an environment with pollution level 2</p>

1.1 Important notes on using the device

 WARNING
Safety notice for connectors with LAN (Local Area Network) marking
A LAN or LAN segment, with all its associated interconnected equipment, shall be entirely contained within a single low-voltage power distribution and within a single building. The LAN is considered to be in an "environment A" according to IEEE802.3 or "environment 0" according to IEC TR 62102, respectively. Never connect directly to TNV-circuits (Telephone Network) or WAN (Wide Area Network).

General notices about use in hazardous areas

 WARNING
Risk of explosion when connecting or disconnecting the device
EXPLOSION HAZARD
DO NOT CONNECT OR DISCONNECT EQUIPMENT WHEN A FLAMMABLE OR COMBUSTIBLE ATMOSPHERE IS PRESENT.

 WARNING
Replacing components
EXPLOSION HAZARD
SUBSTITUTION OF COMPONENTS MAY IMPAIR SUITABILITY FOR CLASS I, DIVISION 2 OR ZONE 2.

 WARNING
Requirements for the cabinet/enclosure
When used in hazardous environments corresponding to Class I, Division 2 or Class I, Zone 2, the device must be installed in a cabinet or a suitable enclosure.

 WARNING
Opening the device
DO NOT OPEN WHEN ENERGIZED.

Safety notices on use in hazardous areas according to ATEX and IECEx

 WARNING**Requirements for the cabinet/enclosure**

To comply with EC Directive 94/9 (ATEX95) or the conditions of IECEx, this enclosure must meet the requirements of at least IP54 in compliance with EN 60529.

The fiber-optic bus connections labeled SCALANCE MM900 (see type plate) may also be led through a hazardous area zone1 (see also Auto-Hotspot, section "Explosion Protection Directive (ATEX)").

 WARNING**Suitable cables for temperatures in excess of 70 °C**

If the cable or conduit entry point exceeds 70°C or the branching point of conductors exceeds 80°C, special precautions must be taken.

If the equipment is operated in an air ambient in excess of 50 °C, only use cables with admitted maximum operating temperature of at least 80 °C.

 WARNING**Protection against transient voltage surges**

Provisions shall be made to prevent the rated voltage from being exceeded by transient voltage surges of more than 40%. This criterion is fulfilled, if supplies are derived from SELV (Safety Extra-Low Voltage) only.

1.2 PELV

Note**Safety extra-low voltage**

The supply of the devices by PELV (Protective Extra Low Voltage) according to DIN VDE 0100-410 or IEC 60364-4-41 is permitted when the generated nominal voltage does not exceed the voltage limits 25 VAC or 60 VDC.

1.3 Important notes on using the device in hazardous areas

 WARNING
WARNING - EXPLOSION HAZARD - DO NOT DISCONNECT WHILE CIRCUIT IS LIVE UNLESS AREA IS KNOWN TO BE NON-HAZARDOUS.

 WARNING
Restricted area of application This equipment is suitable for use in Class I, Division 2, Groups A, B, C and D or non-hazardous locations only.

 WARNING
Restricted area of application This equipment is suitable for use in Class I, Zone 2, Group IIC or non-hazardous locations only.

Note on devices with power supply 100 to 240 V AC

 WARNING
Danger from line voltage The supply voltage for the devices listed is 100 to 240 VAC. This device can only function correctly and safely if it is transported, stored, set up, and installed correctly, and operated and maintained as recommended. Connecting and disconnecting may only be performed by an electrical specialist. Connect or disconnect power supply cables only when the power is turned off.

 WARNING
Devices with a 100 to 240 V AC power supply do not have an ATEX or IECEx approval. Devices with a 100 to 240 V AC power supply are not approved for use in hazardous areas according to EC-RL-94/9 ATEX or IECEx.

NOTICE
Securing cables with dangerous voltage Make sure that the connector cannot be released accidentally by pulling on the connecting cable. Lay the cables in cable ducts or cable channels and secure the cables, where necessary, with cable ties.

Safety requirements for installation

According to the IEC 61131-2 standard and therefore in accordance with the EU directive 2006/95/EC (Low Voltage Directive), the devices are "open equipment" and in accordance with UL/CSA certification, they are an "open type".

To fulfill requirements for safe operation with regard to mechanical stability, flame retardation, stability, and shock-hazard protection, the following alternative types of installation are specified:

- Installation in a suitable cabinet.
- Installation in a suitable enclosure.
- Installation in a suitably equipped, enclosed control room.

1.4 Security recommendations

To prevent unauthorized access, note the following security recommendations.

General

- You should make regular checks to make sure that the device meets these recommendations and/or other security guidelines.
- Evaluate your plant as a whole in terms of security. Use a cell protection concept with suitable products.
- When confidential zones are used, the internal and external network are disconnected, an attacker cannot access the data from the outside.
- Operate the device only within a protected network area.
- Use VPN to encrypt and authenticate communication from and to the devices.
- For data transmission via a non-secure network use an encrypted VPN tunnel (IPsec).
- For operation of the device in a non-secure infrastructure no product liability will be accepted.
- Separate connections correctly (WBM, Telnet, SSH etc.).

Physical access

- Limit physical access to the device to qualified personnel.
The memory card or the C-PLUG contains sensitive data such as certificates, keys etc. that can be read out and modified.
- Lock unused physical ports on the device. Unused ports can be used to gain forbidden access to the plant.

Software (security functions)

- Keep the software up to date. Check regularly for security updates of the product. You will find information on this on the Internet pages "Industrial Security"
- Inform yourself regularly about security advisories and bulletins published by Siemens productCERT.
- Only activate protocols that you really require to use the device.
- Restrict access to the device with a firewall or rules in an access control list (ACL - Access Control List).
- Restrict access to the management of the device with rules in an access control list (ACL).
- The option of VLAN structuring provides good protection against DoS attacks and unauthorized access. Check whether this is practical or useful in your environment.
- Enable logging functions. Use the central logging function to log changes and access attempts centrally. Check the logging information regularly.
- Configure a Syslog server to forward all logs to a central location.

See also

www.siemens.com/industrialsecurity (<http://www.siemens.com/industrialsecurity>)

Passwords

- Define rules for the use of devices and assignment of passwords.
- Regularly update passwords and keys to increase security.
- Change all default passwords for users before you operate the device.
- Only use passwords with a high password strength. Avoid weak passwords for example password1, 123456789, abcdefgh.
- Make sure that all passwords are protected and inaccessible to unauthorized personnel.
- Do not use the same password for different users and systems or after it has expired.

Keys and certificates

This section deals with the security keys and certificates you require to set up SSL.

- We strongly recommend that you create your own SSL certificates and make them available.

There are preset certificates and keys on the device. The preset and automatically created SSL certificates are self-signed. We recommend that you use SSL certificates signed either by a reliable external or by an internal certification authority. The device has an interface via which you can import the certificates and keys.

- Use the certification authority including key revocation and management to sign the certificates.

- Handle user-defined private keys with great caution if you use user-defined SSH or SSL keys.
- Verify certificates and fingerprints on the server and client to avoid "man in the middle" attacks.
- We recommend that you use certificates with a key length of 2048 bits.
- Change keys and certificates immediately, if there is a suspicion of compromise.

Secure/non-secure protocols

- Avoid or disable non-secure protocols, for example Telnet and TFTP. For historical reasons, these protocols are still available, however not intended for secure applications. Use non-secure protocols on the device with caution.
- Avoid or disable non-secure protocols. Check whether use of the following protocols is necessary:
 - PNIO
 - Broadcast pings
 - Non authenticated and unencrypted interfaces
 - ICMP (redirect)
 - MRP, HRP
 - GMRP and IGMP
 - LLDP
 - Syslog
 - RADIUS
 - DHCP Options 66/67
 - TFTP
 - GMRP and GVRP
 - Multicast routing
- The following protocols provide secure alternatives:
 - SNMPv1/v2 → SNMPv3
Check whether use of SNMPv1 is necessary. SNMPv1 is classified as non-secure. Use the option of preventing write access. The product provides you with suitable setting options.
If SNMP is enabled, change the community names. If no unrestricted access is necessary, restrict access with SNMP.
Use SNMPv3 in conjunction with passwords.
 - HTTP → HTTPS
 - TFTP → FTPS
 - Telnet → SSH
 - SNTP → NTP

1.4 Security recommendations

- Use secure protocols when access to the device is not prevented by physical protection measures.
- To prevent unauthorized access to the device or network, take suitable protective measures against non-secure protocols.
- If you require non-secure protocols and services, operate the device only within a protected network area.
- Restrict the services and protocols available to the outside to a minimum.
- For the DCP function, enable the "DCP read-only" mode after commissioning.

Available protocols per port

The following list provides you with an overview of the open ports on this device. Keep this in mind when configuring a firewall.

The table includes the following columns:

- **Protocol**
All protocols that the device supports
- **Port number**
Port number assigned to the protocol
- **Port status**
 - Open
The port is always open and cannot be closed.
 - Open (when configured)
The port is open if it has been configured.

Note

With some protocols the port may be open although the corresponding protocol is disabled, for example TFTP.

- **Default status of the port**
 - Open
As default the port is open.
 - Closed
As default the port is closed.
- **Authentication**
Specifies whether or not the protocol is authenticated during access.

Protocol	Port number	Port status	Default status of the port	Authentication
SSH	TCP/22	Open	Open	Yes
HTTP	TCP/80	Open (when configured)	Open	Yes
HTTPS	TCP/443	Open	Open	Yes
SNTP NTP (secure)	UDP/123	Open (when configured)	Closed	No
SNMP	UDP/161	Open (when configured)	Open	Yes
PROFINET IO	UDP/34964 UDP/1026, 1027	Open	Open	No
PROFINET IO Service	TCP/84	Open	Open	No

Introduction

2.1 Basics of Ethernet switching

Ethernet switching

Ethernet switches forward data packets directly from the input port to the appropriate output port during data exchange based on the address information. Ethernet switches operate on a direct delivery basis.

Essentially, switches have the following functions:

- Connecting collision domains / subnets
Since repeaters and star couplers (hubs) operate at the physical level, their use is restricted to the span of a collision domain. Switches connect collision domains. Their use is therefore not restricted to the maximum span of a repeater network. On the contrary, extremely large networks with very large spans are possible with switches. The distances achieved depend on the fiber-optic interfaces used in the devices and the FO fibers used (see technical specifications).
- Load containment
By filtering the data traffic based on the Ethernet (MAC) addresses, local data traffic remains local. In contrast to repeaters or hubs, which distribute data unfiltered to all ports / network nodes, switches operate selectively. Only data intended for nodes in other subnets is switched from the input port to the appropriate output port of the switch. To make this possible, a table assigning Ethernet (MAC) addresses to output ports is created by the switch in a "teach-in" mode.
- Limiting the propagation of errors to the subnet involved.
By checking the validity of a data packet on the basis of the checksum which each data packet contains, the switch ensures that bad data packets are not transported further. Collisions in one network segment are not passed on to other segments.

The need for Industrial Ethernet switches

With over 95% of LANs based on Ethernet, this is the most commonly used technology. The use of switches is particularly important: They allow extensive networks with large numbers of nodes to be set up, increase the data throughput, and simplify network expansion.

The IE Switches X-300 from SIMATIC NET are designed for use in high-speed plant networks that will also meet future requirements. With the HRP redundancy function and standby linking of rings, high network availability can be achieved. HRP and standby link reconfigures the network within 300 ms. Support of IT standards such as VLAN, RSTP, IGMP, and GARP makes seamless integration of automation networks in existing office networks possible.

The IE Switches X-300 are designed for use in switching cubicles and cabinets.

Technical options (network topologies)

The IE Switches X-300 simplify the expansion of a network regardless of the network topology.

You can use an IE Switch X-300 in the following network topologies:

- Linear structure
- Star/tree structure
- Ring with redundancy manager

The maximum cable length is 70 km for single mode gigabit transmission. A mixed topology consisting of IE Switch X-300 devices and OSMs/ESMs is possible at the electrical ports. A mixed topology consisting of IE Switch X-300 devices and an OSM via the optical ports is not possible.

Using an IE Switch X-300 as the redundancy manager in a ring with redundancy manager provides greater availability. If there is an interruption on the connection between these switches, the IE Switch X-300 used as redundancy manager acts like a switch and in a very short time creates a line from the ring. As a result, a functional, end-to-end structure is restored. For information on this topic, refer to the Configuration Manual "SIMATIC NET - Industrial Ethernet Switches SCALANCE X-300 SCALANCE X-400."

2.2 Product overview

2.2.1 Type designations

Structure of the type designation

The type designation of an IE Switch X-300 is made up of several parts that have the following meaning:

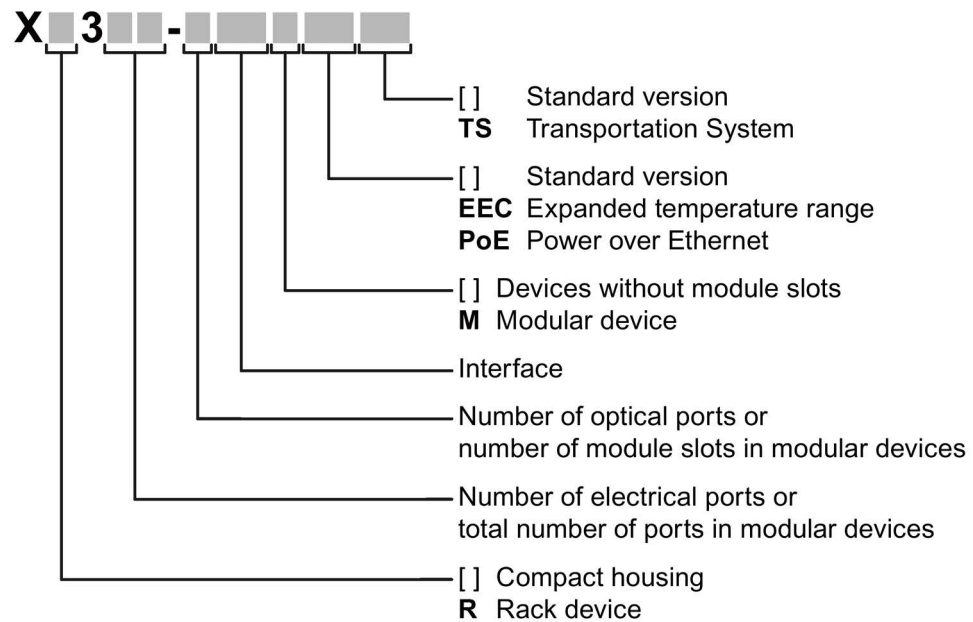

Interfaces of devices without optical ports:

Interface	Property
FE	Electrical RJ-45 port for 10/100 Mbps.
[-]	Electrical RJ-45 port for 10/100 Mbps or 10/100/1000 Mbps.

Interfaces of devices with optical ports:

Interface	Property
FE	SC port 100 Mbps multimode FO cable (up to max. 5 km).
LD FE	SC port 100 Mbps single mode FO cable (up to max. 26 km).
[-]	SC port 1000 Mbps multimode FO cable (up to max. 750 m).
LD	SC port 1000 Mbps single mode FO cable (up to max. 10 km).
LH	SC port 1000 Mbps single mode FO cable (up to max. 40 km).
LH+	SC port 1000 Mbps single mode FO cable (up to max. 70 km).

If information applies to all devices, the term "IE Switches X-300" is used. If information applies to only a particular product group, the relevant names will be used without extra

information on the type or number of interfaces. Examples: "X-300" stands for non-modular devices with a compact housing, "XR-300" means all rack devices, "X-300M" means all modular devices etc.

Note

SCALANCE X320-3LD FE

The SCALANCE X320-3LD FE deviates from the type designation in that it has an SC port for multimode fiber-optic cable up to a maximum of 5 km in length and two SC ports for single mode fiber-optic cable up to a maximum of 26 km in length.

- Port 21: Multimode
- Port 22: LD (long distance, single mode)
- Port 23: LD (long distance, single mode)

2.2.2 Designs of the IE Switch X-300 devices

Designs and variants of the IE Switch X-300

The IE switches of the SCALANCE X-300 product line can have the following designs and variants:

Designs of the IE Switch X300	
X	Compact devices: IE switches X-300 (3 sizes: 60, 120, 180)
XR	Rack devices (R): 19" IE switches (for 19" cabinet installation)
X-300EEC	IE Switches X-300: 19"/2 devices (width: 216 mm)

Table 2- 1

Variant M of the IE Switch X-300	
M	<p>Modular devices (M) are intended to accommodate media modules.</p> <ul style="list-style-type: none"> • Partially modular devices: Some of the ports (slots) are intended to accommodate media modules. Example: X308-2M • Fully modular devices: All ports (slots) are intended to accommodate media modules. Example: XR324-12M

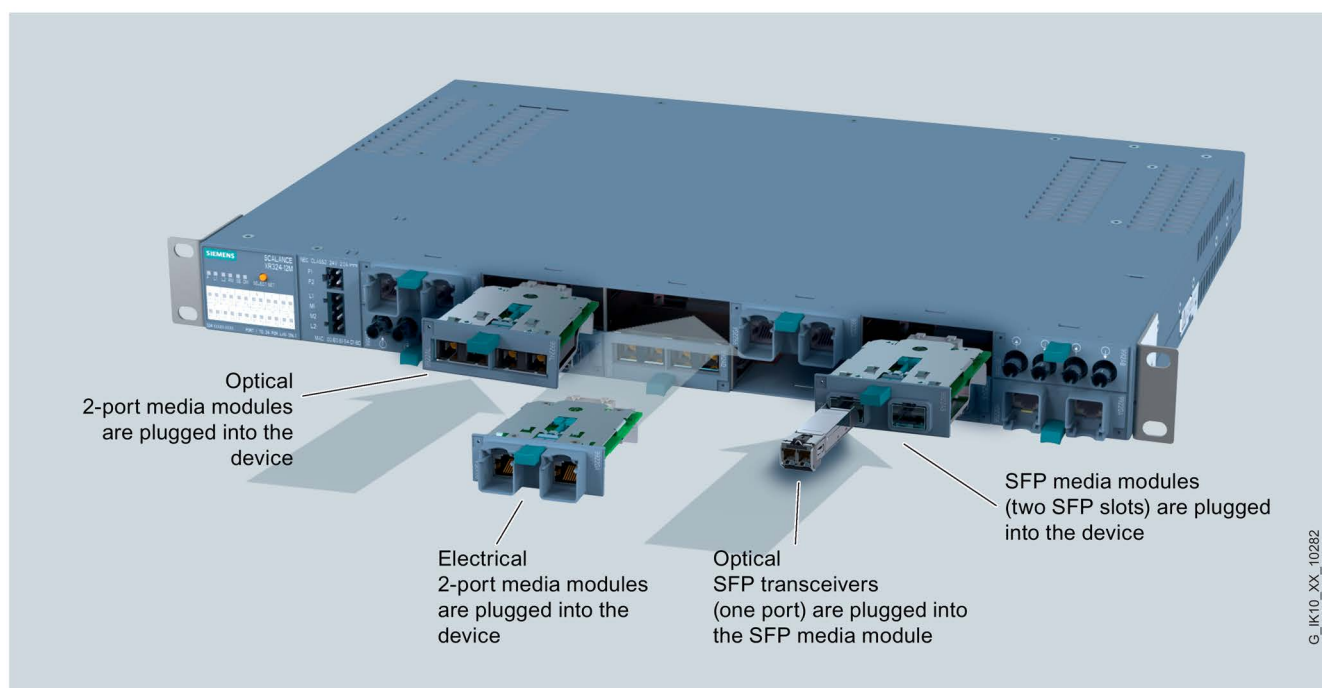

Image 2-1 Designs of the X-300 IE switches, example of plugging media modules into the media module slots of the XR324-12M

2.2.3 X-300 product group

Device	Properties	Order number
X304-2FE	4 x 10/100 Mbps RJ-45 ports electrical 2 x 1000 Mbps, SC ports optical, for glass FO cable (multimode), up to max. 750 m	6GK5 304-2BD00-2AA3
X306-1LD FE	6 x 10/100 Mbps RJ-45 ports electrical 1 x 100 Mbps, SC port optical, for glass FO cable (single mode), up to max. 26 km	6GK5 306-1BF00-2AA3
X307-3	7 x 10/100 Mbps RJ-45 ports electrical 3 x 1000 Mbps, SC ports optical, for glass FO cable (multimode), up to max. 750 m	6GK5 307-3BL00-2AA3 6GK5 307-3BL10-2AA3
X307-3LD	7 x 10/100 Mbps RJ-45 ports electrical 3 x 1000 Mbps, SC ports optical, for glass FO cable (single mode), up to max. 10 km	6GK5 307-3BM00-2AA3 6GK5 307-3BM10-2AA3
X308-2	1 x 10/100/1000 Mbps, RJ-45 ports electrical 7 x 10/100 Mbps RJ-45 ports electrical 2 x 1000 Mbps, SC ports optical, for glass FO cable (multimode), up to max. 750 m	6GK5 308-2FL00-2AA3 6GK5 308-2FL10-2AA3

Device	Properties	Order number
X308-2LD	1 x 10/100/1000 Mbps, RJ-45 ports electrical 7 x 10/100 Mbps RJ-45 ports electrical 2 x 1000 Mbps, SC ports optical, for glass FO cable (single mode), up to max. 10 km	6GK5 308-2FM00-2AA3 6GK5 308-2FM10-2AA3
X308-2LH	1 x 10/100/1000 Mbps, RJ-45 ports electrical 7 x 10/100 Mbps RJ-45 ports electrical 2 x 1000 Mbps, SC ports optical, for glass FO cable (single mode), up to max. 40 km	6GK5 308-2FN00-2AA3 6GK5 308-2FN10-2AA3
X308-2LH+	1 x 10/100/1000 Mbps, RJ-45 ports electrical 7 x 10/100 Mbps RJ-45 ports electrical 2 x 1000 Mbps, SC ports optical, for glass FO cable (single mode), up to max. 70 km	6GK5 308-2FP00-2AA3 6GK5 308-2FP10-2AA3
X310	3 x 10/100/1000 Mbps, RJ-45 ports electrical 7 x 10/100 Mbps RJ-45 ports electrical	6GK5 310-0FA00-2AA3 6GK5 310-0FA10-2AA3
X310FE	10 x 10/100 Mbps RJ-45 ports electrical	6GK5 310-0BA00-2AA3 6GK5 310-0BA10-2AA3
X320-1FE	20 x 10/100 Mbps RJ-45 ports electrical 1 x 100 Mbps, SC port optical, for glass FO cable (multimode), up to max. 5 km	6GK5 320-1BD00-2AA3
X320-3LD FE	20 x 10/100 Mbps RJ-45 ports electrical 1 x 100 Mbps, SC port optical, for glass FO cable (multimode), up to max. 5 km 2 x 100 Mbps, SC ports optical, for glass FO cable (single mode), up to max. 26 km	6GK5 320-3BF00-2AA3

2.2.4 Product group X-300M

Device	Properties	Order number
X308-2M	1 x 24 VDC 4 x 10/100/1000 Mbps, RJ-45 ports electrical 2 x 100/1000 Mbps for 2-port media modules LEDs, connector power supply and data cable outlet on front Diagnostics port at rear	6GK5 308-2GG00-2AA2
X308-2M TS	1 x 12 VDC, module varnished 4 x 10/100/1000 Mbps, RJ-45 ports electrical 2 x 100/1000 Mbps for 2-port media modules LEDs, connector power supply and data cable outlet on front Diagnostics port at rear	6GK5 308-2GG00-2CA2

2.2.5 Product group XR-300M

Device	Properties	Order number
XR324-12M	2 x 24 VDC LEDs, connector power supply and data cable outlet on front Diagnostics port at rear	6GK5 324-0GG00-1AR2
XR324-12M	1 x 100 to 240 VAC LEDs, connector power supply and data cable outlet on front Diagnostics port at rear	6GK5 324-0GG00-3AR2
XR324-12M	2 x 24 VDC LEDs and diagnostics port on front connector power supply and data cable outlet at rear	6GK5 324-0GG00-1HR2
XR324-12M	1 x 100 to 240 VAC LEDs and diagnostics port on front connector power supply and data cable outlet at rear	6GK5 324-0GG00-3HR2
XR324-12M TS	2 x 24 VDC, modules varnished LEDs, connector power supply and data cable outlet on front Diagnostics port at rear	6GK5 324-0GG00-1CR2

2.2.6 X-300EEC product group

Product / ports	Properties	Order number
X302-7EEC <ul style="list-style-type: none"> • 2 electrical ports • 7 optical ports 	1 x power supply unit 24 to 48 VDC	6GK5302-7GD00-1EA3
	1 x power supply unit 24 to 48 VDC Printed board varnished	6GK5302-7GD00-1GA3
	2 x power supply unit 24 to 48 VDC	6GK5302-7GD00-2EA3
	2 x power supply unit 24 to 48 VDC Printed board varnished	6GK5302-7GD00-2GA3
	1 x power supply unit 100 to 240 VAC / 60 to 250 VDC	6GK5302-7GD00-3EA3
	1 x power supply unit 100 to 240 VAC / 60 to 250 VDC Printed board varnished	6GK5302-7GD00-3GA3
	2 x power supply unit 100 to 240 VAC / 60 to 250 VDC	6GK5302-7GD00-4EA3
	2 x power supply unit 100 to 240 VAC / 60 to 250 VDC Printed board varnished	6GK5302-7GD00-4GA3
X307-2EEC <ul style="list-style-type: none"> • 7 electrical ports • 2 optical ports 	1 x power supply unit 24 to 48 VDC	6GK5307-2FD00-1EA3
	1 x power supply unit 24 to 48 VDC Printed board varnished	6GK5307-2FD00-1GA3
	2 x power supply unit 24 to 48 VDC	6GK5307-2FD00-2EA3
	2 x power supply unit 24 to 48 VDC Printed board varnished	6GK5307-2FD00-2GA3

Product / ports	Properties	Order number
	1 x power supply unit 100 to 240 VAC / 60 to 250 VDC	6GK5307-2FD00-3EA3
	1 x power supply unit 100 to 240 VAC / 60 to 250 VDC Printed board varnished	6GK5307-2FD00-3GA3
	2 x power supply unit 100 to 240 VAC / 60 to 250 VDC	6GK5307-2FD00-4EA3
	2 x power supply unit 100 to 240 VAC / 60 to 250 VDC Printed board varnished	6GK5307-2FD00-4GA3

* See naming key below

2.2.7 XR-300M EEC product group

Device	Properties	Order number
XR324-4M EEC	1 x 24 to 48 VDC LEDs, connector data cable outlet on front Connector power supply and diagnostics port at rear	6GK5 324-4GG00-1ER2
	2 x 24 to 48 VDC LEDs, connector data cable outlet on front Connector power supply and diagnostics port at rear	6GK5 324-4GG00-2ER2
	1 x 100 to 240 VAC / 60 to 250 VDC LEDs, connector data cable outlet on front Connector power supply and diagnostics port at rear	6GK5 324-4GG00-3ER2
	2 x 100 to 240 VAC / 60 to 250 VDC LEDs, connector data cable outlet on front Connector power supply and diagnostics port at rear	6GK5 324-4GG00-4ER2
	1 x 24 to 48 VDC LEDs, connector power supply on front Data cable outlet and diagnostics port at rear	6GK5 324-4GG00-1JR2
	2 x 24 to 48 VDC LEDs, connector power supply on front Data cable outlet and diagnostics port at rear	6GK5 324-4GG00-2JR2
	1 x 100 to 240 VAC / 60 to 250 VDC LEDs, connector power supply on front Data cable outlet and diagnostics port at rear	6GK5 324-4GG00-3JR2
	2 x 100 to 240 VAC / 60 to 250 VDC LEDs, connector power supply on front Data cable outlet and diagnostics port at rear	6GK5 324-4GG00-4JR2

2.2.8 Product group X-300M PoE

Device:	Properties	Order number
X308-2M PoE	4 x 10/100/1000 Mbps, RJ-45 ports electrical 2 x 100/1000 Mbps for 2-port media modules	6GK5 308-2QG00-2AA2

Note

For more information on Power over Ethernet (PoE), refer to the Configuration Manual X-300/X-400.

2.2.9 Product group XR-300M PoE

Device	Properties	Order number
XR324-4M PoE	1 x 24 VDC, PoE LEDs, connector power supply and data cable outlet on front Diagnostics port at rear.	6GK5 324-4QG00-1AR2
	1 x 100 to 240 VAC, PoE LEDs, connector power supply and data cable outlet on front Diagnostics port at rear.	6GK5 324-4QG00-3AR2
	1 x 24 VDC, PoE LEDs and diagnostics port at rear, connector power supply and data cable outlet at rear	6GK5 324-4QG00-1HR2
	1 x 100 to 240 VAC, PoE LEDs and diagnostics port on front, connector power supply and data cable outlet at rear	6GK5 324-4QG00-3HR2
XR324-4M PoE TS	1 x 24 VDC, PoE, module varnished LEDs, connector power supply and data cable outlet on front Diagnostics port at rear.	6GK5 324-4QG00-1CR2

Note

For more information on Power over Ethernet (PoE), refer to the Configuration Manual X-300/X-400.

2.2.10 SFP transceiver

SFP transceiver

Type	Properties	Article number
SFP991-1 *	1 x 100 Mbps, LC port optical for glass FO cable (multimode), up to max. 5 km	6GK5 991-1AD00-8AA0
SFP991-1 (C) *	1 x 100 Mbps, SC port optical, for glass FO cable (multimode), up to max. 5 km, varnished	6GK5 991-1AD00-8FA0
SFP991-1LD *	1 x 100 Mbps LC port optical for glass FO cable (single mode) up to max. 26 km	6GK5 991-1AF00-8AA0
SFP991-1LD (C) *	1 x 100 Mbps LC port optical for glass FO cable (single mode) up to max. 26 km, varnished	6GK5 991-1AF00-8FA0
SFP991-1LH+ *	1 x 100 Mbps LC port optical for glass FO cable (single mode) up to max. 70 km	6GK5 991-1AE00-8AA0
SFP991-1ELH200 *	1 x 100 Mbps LC port optical for glass FO cable (single mode) up to max. 200 km	6GK5 991-1AE30-8AA0
SFP992-1	1 x 1000 Mbps, LC port optical for glass FO cable (multimode), up to max. 750 m	6GK5 992-1AL00-8AA0
SFP992-1LD	1 x 1000 Mbps LC port optical for glass FO cable (single mode) up to max. 10 km	6GK5 992-1AM00-8AA0
SFP992-1LD (C)	1 x 1000 Mbps LC port optical for glass FO cable (single mode) up to max. 10 km, varnished	6GK5 992-1AM00-8FA0
SFP992-1LH	1 x 1000 Mbps LC port optical for glass FO cable (single mode) up to max. 40 km	6GK5 992-1AN00-8AA0
SFP992-1LH+	1 x 1000 Mbps LC port optical for glass FO cable (single mode) up to max. 70 km	6GK5 992-1AP00-8AA0
SFP992-1ELH	1 x 1000 Mbps LC port optical for glass FO cable (single mode) up to max. 120 km	6GK5 992-1AQ00-8AA0

* Cannot be operated in SFP+ slots.

Media modules

Note

The SFP media modules MM992-2SFP may only be fitted with approved transceivers. The media module can be fitted with up to two pluggable transceivers.

The SFP media modules MM992-4SFP may only be fitted with approved transceivers. The media module can be fitted with up to four pluggable transceivers.

Type	Properties	Article number	Labeling on the device
MM992-2SFP	2 x 100 / 1000 Mbps, SFP media module	6GK5 992-2AS00-8AA0	9922AS
MM992-4SFP	4 x 100 / 1000 Mbps, SFP media module	6GK5 992-4AS00-8AA0	9924AS

2.2.11 MM900 media modules

Note

Type designation and labeling of a media module differ

Example: The device with order number 6GK5 992-2AS00-8AA0 is called "MM992-2SFP", the labeling on the device is "9922AS".

The labeling on the devices is shown in bold face in the following table following the [order numbers].

Note

Media modules for SFP transceivers

Only the media modules MM992-2SFP and MM992-2SFP (C) may be fitted with approved SFP transceivers. These SFP media modules can be fitted with up to two SFPs.

Note

Supplement (C) in the type name

Media modules with the supplement (C) in the type name have varnished printed circuit boards (conformal coating).

Media module	Properties	Order number Labeling on the device
MM992-2CUC	2 x 10/100/1000 Mbps, RJ-45 ports electrical with securing collar	6GK5 992-2GA00-8AA0 9922GA
MM992-2CUC (C)	2 x 10/100/1000 Mbps, RJ-45 ports electrical with securing collar, varnished	6GK5 992-2GA00-8FA0 9922GA
MM992-2CU	2 x 10/100/1000 Mbps, RJ-45 port electrical without securing collar	6GK5 992-2SA00-8AA0 9922SA
MM992-2M12 (C)	2 x 10/100/1000 Mbps, GE M12 connector electrical, varnished	6GK5 992-2HA00-0AA0 9922HA
MM992-2VD	2 x 10/100/1000 Mbps, RJ-45 ports electrical with securing collar, variable distance	6GK5 992-2VA00-8AA0 9922VA

Media module	Properties	Order number Labeling on the device
MM992-2SFP	2 x 100/1000 Mbps, SFP media module	6GK5 992-2AS00-8AA0 9922AS
MM992-2SFP (C)	2 x 100/1000 Mbps, SFP media module, varnished	6GK5 992-2AS00-8FA0 9922AS
MM991-2	2 x 100 Mbps, BFOC port optical, for glass FO cable (multimode), up to max. 5 km	6GK5 991-2AB00-8AA0 9912AB
MM991-2FM	2 x 100 Mbps, BFOC port optical, for glass FO cable (multimode) with diagnostics up to max. 5 km	6GK5 991-2AB01-8AA0 9912AB
MM991-2LD	2 x 100 Mbps, BFOC port optical, for glass FO cable (single mode), up to max. 26 km	6GK5 991-2AC00-8AA0 9912AC
MM991-2 (SC)	2 x 100 Mbps, SC ports optical, for glass FO cable (multimode), up to max. 5 km	6GK5 991-2AD00-8AA0 9912AD
MM991-2LD (SC)	2 x 100 Mbps, SC ports optical, for glass FO cable (single mode), up to max. 26 km	6GK5 991-2AF00-8AA0 9912AF
MM991-2LH+ (SC)	2 x 100 Mbps, SC ports optical, for glass FO cable (single mode), up to max. 70 km	6GK5 991-2AE00-8AA0 9912AE
MM991-2P	2 x 100 Mbps SC RJ ports optical for Plastic Optical Fiber (POF) up to max. 50 m or Polymer Cladded Fiber (PCF) up to max. 100 m	6GK5 991-2AH00-8AA0 9912AH
MM992-2	2 x 1000 Mbps, SC ports optical, for glass FO cable (multimode), up to max. 750 m	6GK5 992-2AL00-8AA0 9922AL
MM992-2 (C)	2 x 1000 Mbps, SC ports optical, for glass FO cable (multimode), up to max. 750 m, varnished	6GK5 992-2AL00-8FA0 9922AL
MM992-2LD	2 x 1000 Mbps, SC ports optical, for glass FO cable (single mode), up to max. 10 km	6GK5 992-2AM00-8AA0 9922AM
MM992-2LH	2 x 1000 Mbps, SC ports optical, for glass FO cable (single mode), up to max. 40 km	6GK5 992-2AN00-8AA0 9922AN
MM992-2LH+	2 x 1000 Mbps, SC ports optical, for glass FO cable (single mode), up to max. 70 km	6GK5 992-2AP00-8AA0 9922AP
MM992-2ELH	2 x 1000 Mbps, SC ports optical, for glass FO cable (single mode), up to max. 120 km	6GK5 992-2AQ00-8AA0 9922AQ

Type key for the MM900 media modules

The type designation of an MM900 media module is made up of several parts that have the following meaning:

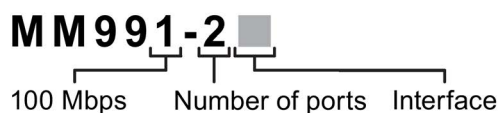

Interface	Property
[-]	BFOC port 100 Mbps multimode FO cable
LD	BFOC port 100 Mbps single mode FO cable
(SC)	SC port 100 Mbps multimode FO cable (up to max. 5 km)
LD (SC)	SC port 100 Mbps single mode FO cable (up to max. 26 km)
LH+ (SC)	SC port 100 Mbps single mode FO cable (up to max. 70 km)
P	SC RJ port 100 Mbps POF or PCF
FM	BFOC port 100 Mbps multimode FO cable with diagnostics

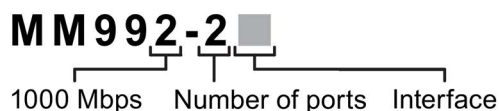

Interface	Property
CU	RJ-45 port electrical 10/100/1000 Mbps without securing collar
CUC	RJ-45 port electrical 10/100/1000 Mbps with securing collar
M12	M12 connection electrical 10/100/1000 Mbps
VD	RJ-45 port electrical 10/100/1000 Mbps with securing collar (up to max. 1000 m)
[-]	SC port 1000 Mbps multimode FO cable (up to max. 750 m)
LD	SC port 1000 Mbps single mode FO cable (up to max. 10km)
LH	SC port 1000 Mbps single mode FO cable (up to max. 40 km)
LH+	SC port 1000 Mbps single mode FO cable (up to max. 70 km)
ELH	SC port 1000 Mbps single mode FO cable (up to max. 120 km)
SFP	SFP media module

Network topologies

3.1 Linear structure

Functional description

Linear structures can be created with the IE Switches X-300. The cascading depth and total span of a network are limited only by the signal propagation times of the communication connections.

Properties of the linear structure

Each IE Switch X-300 communicates over a TP or FO cable with a neighboring Ethernet switch. Communication is possible over the optical or the electrical ports.

Configuration example

Sample configuration with SCALANCE X308-2, SIMATIC S7-300/400 and operator panel as end devices.

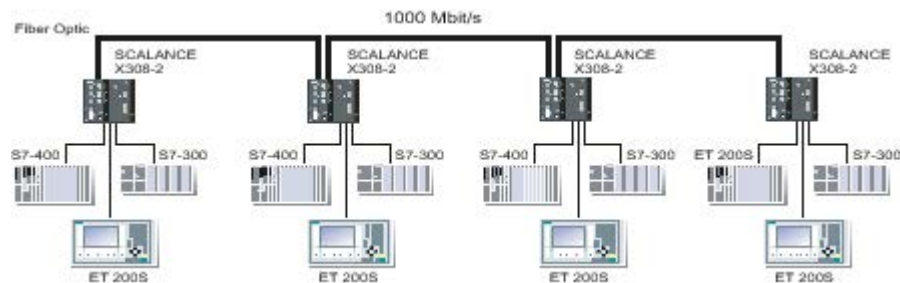

Image 3-1 Linear structure (optical)

3.2 Star/tree structure

Functional description

Star/tree structures can be created with the IE Switches X-300. The cascading depth and total span of a network are limited only by the signal propagation times of the communication connections.

Properties of a star structure

Each IE Switch X-300 communicates over a TP or FO cable with a central switch with which all other switches are also connected within a star structure. Communication is possible over the optical or the electrical ports.

Configuration example

Sample electrical configurations with SCALANCE X310, SCALANCE X-200, SIMATIC S7-300/400, SIMATIC ET 200, and operator panels as end devices.

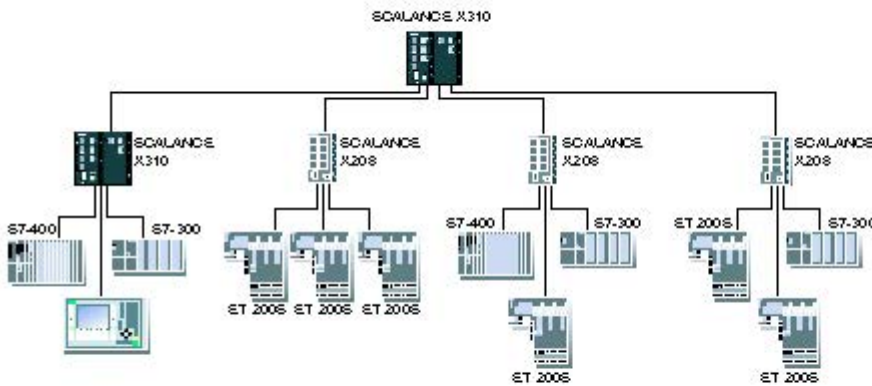

Image 3-2 Star structure (electrical)

3.3 Ring with redundancy manager

Ring with redundancy manager

To increase availability, linear topologies of up to 100 switches can be closed to form a ring:

- Optical: SCALANCE X-400, SCALANCE X-300, SCALANCE X-200
- Electrical: SCALANCE X-400, SCALANCE X-300, SCALANCE X-200 or ESM

Functional description

The two ends of the bus are closed to form a ring by a IE Switch X-300 operating as a redundancy manager. Both the redundancy manager and the other IE switches (redundancy clients) in the ring must be interconnected via their ring ports (see below).

The redundancy manager function is enabled by the SELECT/SET button or by a setting in the software. For more detailed information, refer to the configuration manual "SCALANCE X-300 and SCALANCE X-400 Industrial Ethernet Switches".

In contrast to the ring ports of the redundancy clients, the ring ports of the redundancy manager are disconnected when the network is operating problem-free. The IE Switch X-300 operating in the role of redundancy manager mode monitors the connected bus over its ring ports and switches the ring ports through if there is an interruption on the connected bus; in other words, it restores a functioning bus over this substitute path. Reconfiguration is achieved within 0.3 s. As soon as the problem is eliminated, the original topology is restored; in other words, the ring ports in the redundancy manager are disconnected from each other again.

In a ring with media redundancy, only one device can operate as the redundancy manager.

Ring ports

An electrical ring with redundancy manager can be set up via the RJ-45 connectors that allow attachment of electrical (twisted pair) connections (10, 100 and/or 1000 Mbps). The SCALANCE X310FE is an exception to this. This device only allows attachment of electrical (twisted-pair) connections at 10 or 100 Mbps.

The use of the IE Switch X-300 in an optical ring (1000 Mbps, with SCALANCE X-300EEC 100Mbps) with a redundancy manager is also possible with the exception of the devices SCALANCE X310 and SCALANCE X310FE.

You can configure which ports take on the function of ring ports individually. The following table shows the factory defaults for the ring ports.

Device	Factory setting for the ring ports	
	Electrical	Optical
X-304-2FE		Port 1 and port 2
X306-1LD FE	Port 2 and port 3	
X307-3		Port 9 and port 10
X307-3LD		Port 9 and port 10
X308-2		Port 9 and port 10
X308-2LD		Port 9 and port 10
X308-2LH		Port 9 and port 10
X308-2LH+		Port 9 and port 10
X310	Port 9 and port 10	(no optical ports)
X310FE	Port 9 and port 10	(no optical ports)
X320-1FE	Port 1 and port 2	
X320-3LD FE	Port 1 and port 2	
X308-2M	Port 1 and port 2	
X308-2M TS	Port 1 and port 2	
X308-2M PoE	Port 1 and port 2	
X302-7 EEC	Port 8 and port 9	
X307-2 EEC	Port 8 and port 9	
XR324-12M	Port 1.1 and port 1.2	

3.3 Ring with redundancy manager

Device	Factory setting for the ring ports	
	Electrical	Optical
XR324-12M TS	Port 1.1 and port 1.2	
XR324-4M EEC	Port 1 and port 2	
XR324-4M PoE	Port 1 and port 2	
XR324-4M PoE TS	Port 1 and port 2	

Configuration example

Sample configurations with IE Switch X-300, SIMATIC S7-200/300/400, operator control and monitoring system, H system, and PC as end devices.

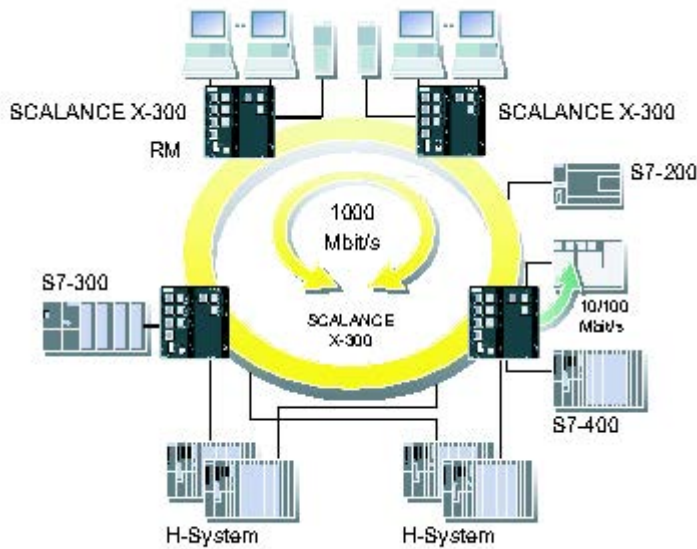

Image 3-3 Gigabit ring with redundancy manager (RM)

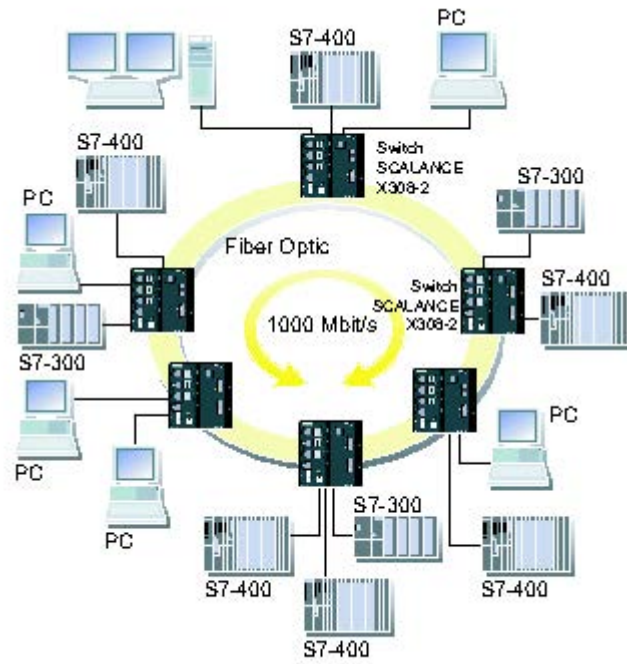

Image 3-4 Ring with FO cable and redundancy manager

3.4 Redundant coupling of network segments

Redundant coupling of network segments

The example of redundant coupling of two network segments as shown here, for example rings with a redundancy manager, can be implemented homogeneously with all SCALANCE X300 variants.

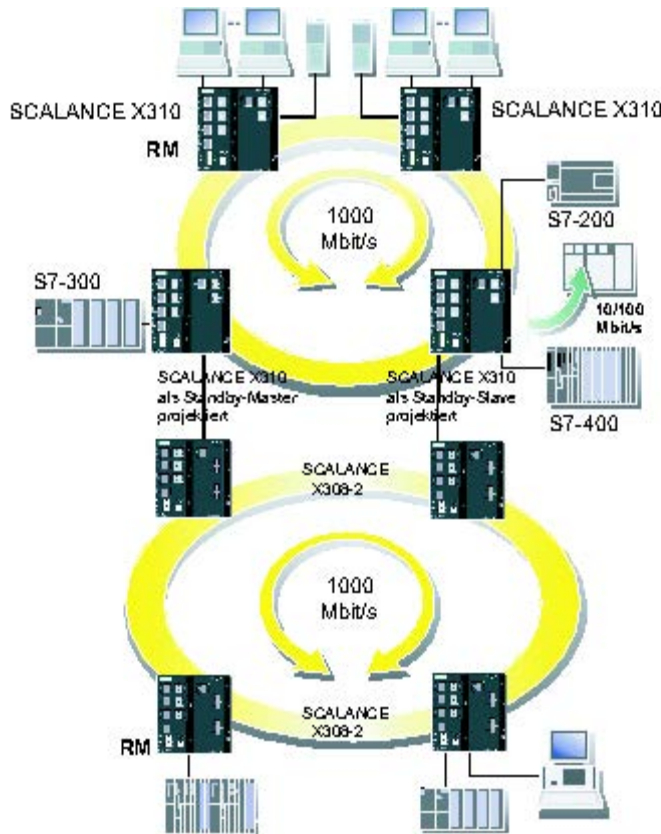

Image 3-5 Redundant coupling of two subnets in mixed operation with SCALANCE X310 and SCALANCE X308-2

In this case, network segments are rings with a redundancy manager (RM). The rings can also be interrupted at one point (linear topology).

For a redundant link as shown in the figure, two IE Switches X-300 must be configured within a network segment. This configuration is set in Web Based Management, Command Line Interface or using SNMP access. For more detailed information, refer to the "Configuration Manual SCALANCE X-300 and SCALANCE X-400 Industrial Ethernet Switches". The two IE Switches X-300 connected in the configuration exchange data frames with each other to

synchronize their operating statuses (one device is master and the other slave). If there are no problems, only the link from the master to the other network segment is active. If this link fails (for example due to a link-down or a device failure), the slave activates its link as long as the problem persists. Reconfiguration takes place within 0.3 s.

Note

If IE Switches X-300 or SCALANCE X408-2 devices are used exclusively for redundant coupling of the gigabit rings, the coupling links can also be designed with a gigabit transmission rate.

Description of the device

4.1 Compatibility of SCALANCE X-300

Compatibility list

Note**Modular devices (M)**

The MM900 media modules and the SFP transceivers are used only in modular devices (M).

The following products and devices are compatible with IE Switches X-300:

- End devices:

All SIMATIC NET products with a TP interface can be connected to the ports of IE Switches X-300.

- Network components with a bus (linear) or star structure:

ESM/OSM

OMC (TP cable max. 6 m long)

SCALANCE X005

SCALANCE X-100

SCALANCE XB000

SCALANCE XB000G

SCALANCE X-100 media converter

SCALANCE X-200

SCALANCE X-200IRT

SCALANCE XF200

SCALANCE XF204IRT

SCALANCE X-300

SCALANCE X-400

SCALANCE S-600

SCALANCE W-700

4.2 Product groups

- Network components in a ring structure with IE Switch X-300 as redundancy manager
 - Electrical ring structure:
 - ESM/OSM
 - SCALANCE X-200
 - SCALANCE X-200IRT
 - SCALANCE XF200
 - SCALANCE XF204IRT
 - SCALANCE X-300 (it may be necessary to configure other ring ports)
 - SCALANCE X-400
 - Optical ring structure:
 - SCALANCE X-400
 - SCALANCE X-300 (exceptions SCALANCE X310 and SCALANCE X310FE)
- Redundant coupling of networks
 - In the network segment with the master-slave pair to be configured:
 - SCALANCE X-400
 - SCALANCE X-300
 - In the standby coupling also to SCALANCE X-200
 - In the network segment to be coupled:
 - ESM/OSM
 - SCALANCE X-200
 - SCALANCE X-200IRT
 - SCALANCE XF200
 - SCALANCE XF204IRT
 - SCALANCE X-300
 - SCALANCE X-400

Note

All compatibility information assumes the correct use of the TP and FOC cables.

4.2 Product groups

4.2.1 X-300 product group

4.2.1.1 SCALANCE X304-2FE product characteristics

Possible attachments

The SCALANCE X304-2FE provides the following options for the connection of end devices or other network segments:

- 4 RJ-45 jacks
- 2 FO ports (for multimode fiber)



Image 4-1 X304-2FE

Column	1	2
Port number	P1	P3
		P4
	P2	P5
		P6
Connection type	Optical: Fast Ethernet	Electrical: Fast Ethernet

4.2.1.2 SCALANCE X306-1LD FE product characteristics

Possible attachments

The SCALANCE X306-1LD FE provides the following options for the connection of end devices or other network segments:

- 6 RJ-45 jacks
- 1 FO port (for single mode fiber)



Image 4-2 SCALANCE X306-1LD FE

Column	1	2
Port number	P1 *)	P4
		P5
	P2	P6
	P3	P7
Connection type	Electrical: Fast Ethernet *) Optical: Fast Ethernet	Electrical: Fast Ethernet

4.2.1.3 SCALANCE X307-3 product characteristics

Possible attachments

The SCALANCE X307-3 provides the following options for the connection of end devices or other network segments:

- 7 RJ-45 jacks
- 3 FO ports (for multimode fiber)



Image 4-3 SCALANCE X307-3

Column	1	2	3	4
Port number	P1	P5	P8	P9
	P2	P6		
	P3	P7	-	P10
	P4	-		
Connection type	Electrical: Fast Ethernet		Optical: Gigabit Ethernet	

4.2.1.4 SCALANCE X307-3LD product characteristics

Possible attachments

The SCALANCE X306-3LD provides the following options for the connection of end devices or other network segments:

- 7 RJ-45 jacks
- 3 FO ports (for single mode fiber)



Image 4-4 SCALANCE X307-3LD

Column	1	2	3	4
Port number	P1	P5	P8	P9
	P2	P6		
	P3	P7	-	P10
	P4	-		
Connection type	Electrical: Fast Ethernet		Optical: Gigabit Ethernet	

4.2.1.5 SCALANCE X308-2LH product characteristics

Possible attachments

The SCALANCE X308-2LH provides the following options for the connection of end devices or other network segments:

- 8 RJ-45 jacks
- 2 FO ports (for single mode fiber)



Image 4-5 SCALANCE X308-2LH

Column	1	2	3	4
Port number	P1	P5	P8	P9
	P2	P6	-	
	P3	P7	-	P10
	P4	-	-	
Connection type	Electrical: Fast Ethernet		Electrical: Gigabit Ethernet	Optical: Gigabit Ethernet

4.2.1.6 SCALANCE X308-2LH+ product characteristics

Possible attachments

The SCALANCE 308-2LH+ provides the following options for the connection of end devices or other network segments:

- 8 RJ-45 jacks
- 2 FO ports (for single mode fiber)



Image 4-6 SCALANCE X308-2LH+

Column	1	2	3	4
Port number	P1	P5	P8	P9
	P2	P6	-	
	P3	P7	-	P10
	P4	-	-	
Connection type	Electrical: Fast Ethernet		Electrical: Gigabit Ethernet	Optical: Gigabit Ethernet

4.2.1.7 SCALANCE X308-2 product characteristics

Possible attachments

The SCALANCE X308-2 provides the following options for the connection of end devices or other network segments:

- 8 RJ-45 jacks
- 2 FO ports (for multimode fiber)



Image 4-7 SCALANCE X308-2

Column	1	2	3	4
Port number	P1	P5	P8	P9
	P2	P6	-	
	P3	P7	-	P10
	P4	-	-	
Connection type	Electrical: Fast Ethernet		Electrical: Gigabit Ethernet	Optical: Gigabit Ethernet

4.2.1.8 SCALANCE X308-2LD product characteristics

Possible attachments

The SCALANCE X308-2LD provides the following options for the connection of end devices or other network segments:

- 8 RJ-45 jacks
- 2 FO ports (for single mode fiber)



Image 4-8 SCALANCE X308-2LD

Column	1	2	3	4
Port number	P1	P5	P8	P9
	P2	P6	-	
	P3	P7	-	P10
	P4	-	-	
Connection type	Electrical: Fast Ethernet		Electrical: Gigabit Ethernet	Optical: Gigabit Ethernet

4.2.1.9 SCALANCE X310 product characteristics

Possible attachments

The SCALANCE X310 provides the following options for the connection of end devices or other network segments:

- 10 RJ-45 jacks



Image 4-9 SCALANCE X310

Column	1	2	3	4
Port number	P1	P5	P8	P9
	P2	P6	-	P10
	P3	P7	-	-
	P4	-	-	-
Connection type	Electrical: Fast Ethernet		Electrical: Gigabit Ethernet	

4.2.1.10 SCALANCE X310FE product characteristics

Possible attachments

The SCALANCE X310FE provides the following options for the connection of end devices or other network segments:

- 10 RJ-45 jacks



Image 4-10 SCALANCE X310FE

Column	1	2	3	4
Port number	P1	P5	P8	P9
	P2	P6	-	P10
	P3	P7	-	-
	P4	-	-	-
Connection type	Electrical: Fast Ethernet			

4.2.1.11 SCALANCE X320-1FE product characteristics

Possible attachments

The SCALANCE X320-1 FE provides the following options for the connection of end devices or other network segments:

- 20 RJ-45 jacks
- 1 FO port (for multimode fiber)



Image 4-11 SCALANCE X320-1 FE

Column	1	2	3	4	5	6
Port number	P1	P5	P9	P13	P17	P21
	P2	P6	P10	P14	P18	-
	P3	P7	P11	P15	P19	-
	P4	P8	P12	P16	P12	-
Connection type	Electrical: Fast Ethernet					Optical: Fast Ethernet

4.2.1.12 SCALANCE X320-3LD FE product characteristics

Possible attachments

The SCALANCE X320-3LD FE provides the following options for the connection of end devices or other network segments:

- 20 RJ-45 jacks
- 1 FO port (for multimode fiber)
- 2 FO ports (for single mode fiber)



Image 4-12 SCALANCE X320-3LD FE

Column	1	2	3	4	5	6
Port number	P1	P5	P9	P13	P17	P21
	P2	P6	P10	P14	P18	P22
	P3	P7	P11	P15	P19	P23
	P4	P8	P12	P16	P20	-
Connection type	Electrical: Fast Ethernet					Optical: Fast Ethernet

4.2.2 Product group X-300M

Possible attachments

The SCALANCE X308-2M and X308-2M TS are partly modular devices and each has 8 ports.

- **4 fixed ports in the base device:**
4 electrical RJ-45 jacks (with securing collars) for connection of end devices or other network segments.
- **4 modular ports via module slots:**
Two media modules (optical or electrical as required) can be combined using slots (S1-S2) depending on the application. End devices and other network segments are connected according to the media modules being used.

Note

When shipped, the slots for the media modules have a dummy cover fitted.



Image 4-13 SCALANCE X308-2M with dummy covers

Possible attachments (example)

 CAUTION
<p>Use only approved media modules in the module slots</p> <p>The connection of end devices or other network segments does not depend on the module slot, but rather on the selected media module.</p> <p>Refer to the section Media module installation in slot.</p>

Example of connections



Image 4-14 SCALANCE X308-2M with MM992-2 and MM991-2

Column	1	2	3	4
Slot number	-	-	S1	S2
Media modules used			MM992-2	MM991-2
Port number	-	P1	P5	P7
	-	P2		
	-	P3	P6	P8
	-	P4		
Connection type	-	Optical: Gigabit Ethernet	Connection type depending on module used	

4.2.3 Product group XR-300M

Possible attachments

The SCALANCE XR324-12M is a fully modular device and has 24 ports.

- **0 fixed ports on the base device**
- **24 modular ports via module slots:**
12 media modules (optical or electrical as required) can be combined using slots (S1-S12) depending on the application. End devices and other network segments are connected according to the modules being used.

Note

When shipped, the slots for the media modules have a dummy cover fitted.

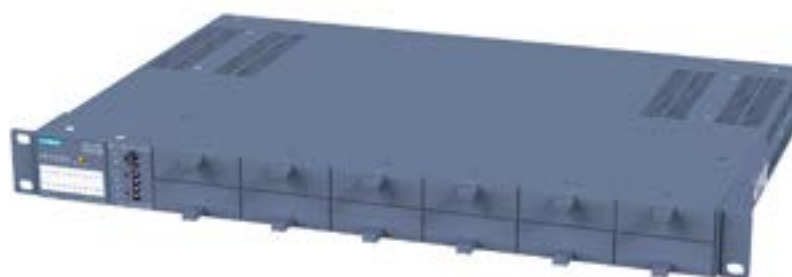

Image 4-15 SCALANCE XR324-12M with blind covers

Overview of the SCALANCE XR324-12M product

Device	Variant	Order number
XR324-12M	2 x 24 VDC LEDs, connector power supply and data cable outlet on front Diagnostics port at rear	6GK5 324-0GG00-1AR2
XR324-12M	1 x 100 to 240 VAC LEDs, connector power supply and data cable outlet on front Diagnostics port at rear	6GK5 324-0GG00-3AR2
XR324-12M	2 x 24 VDC LEDs and diagnostics port on front connector power supply and data cable outlet at rear	6GK5 324-0GG00-1HR2

4.2 Product groups

Device	Variant	Order number
XR324-12M	1 x 100 to 240 VAC, LEDs and diagnostics port on front connector power supply and data cable outlet at rear	6GK5 324-0GG00-3HR2
XR324-12M TS	2 x 24 VDC, modules varnished LEDs, connector power supply and data cable outlet on front Diagnostics port at rear	6GK5 324-0GG00-1CR2

Example of a configuration

 CAUTION
<p>Use only approved media modules in the module slots</p> <p>The connection of end devices or other network segments does not depend on the module slot, but rather on the selected media module.</p> <p>Refer to the section Media module installation in slot.</p>



Image 4-16 SCALANCE XR324-12M with MM900

Slot number	S1	S2	S3	S4	S5	S6
Media modules used	MM992-2CUC	MM992-2CUC	MM992-2CUC	MM991-2 (SC)	MM991-2 (SC)	MM991-2 (SC)
Port number	P1 P2	P1 P2	P1 P2	P1 P2	P1 P2	P1 P2
Slot number	S7	S8	S9	S10	S11	S12
Media modules used	MM992-2CUC	MM992-2CUC	MM992-2CUC	MM991-2	MM991-2	MM991-2
Port number	P1 P2	P1 P2	P1 P2	P1 P2	P1 P2	P1 P2

4.2.4 X-300EEC product group

4.2.4.1 Characteristics of the X-300EEC product group

Variants

The SCALANCE X-300EEC is a 19"/2 device with 9 ports for the connection of end devices or other network segments. There are 2 device types with the following ports:

- **SCALANCE X302-7EEC**
 - 2 x RJ-45 jacks
 - 7 x FO ports for multimode fiber, LC connector
- **SCALANCE X307-2EEC**
 - 7 x RJ-45 jacks
 - 2 x FO ports for multimode fiber, LC connector

Device versions

The X-300EEC is available in the following alternative versions:

- **Power supply**
 - Power supply unit 24 to 48 VDC
 - Multirange power supply unit 100 to 240 VAC / 60 to 250 VDC
- **Power supply unit**
 - Single
 - Redundant
- **Printed board**
 - Varnished (suitable for aggressive environments)
 - Unvarnished

This combination of versions results in the product variants listed in section X-300EEC product group (Page 31).



Image 4-17 SCALANCE X302-7EEC (from below) with protective bracket and LC connector

Replacing the C-PLUG

In the X-300EEC devices, the slot for the C-PLUG is on the top on the housing.



Image 4-18 C-PLUG of the X-300EEC

NOTICE

The C-PLUG may only be removed or inserted when the power supply to the device is turned off.

In a device with a varnished printed circuit board, you may only use a C-PLUG with a varnished board.

To remove the C-PLUG, open the slider and close it again after inserting the C-PLUG.

Terminal block for signaling contact and power supply

The terminal block of the X-300EEC for connecting the signaling contact and power supply has the following terminals:

- F1, F2: Signaling contact

The 2 signaling contacts on the device version with a redundant power supply are energized in parallel.

- L1, M1: Power supply 1
- L2, M2: Power supply 2 (redundant version)

The power supply units for the power supply are available in the following versions:

- 24 to 48 VDC
- As multirange power supply unit 100 to 240 VAC / 60 to 250 VDC

RJ-45 interface

The RJ-45 ports of the IE Switch X-300EEC are fitted with a securing bracket instead of a securing collar.

To increase mechanical stability, secure the IE FC RJ-45 PLUGs to this securing bracket with a cable binder.

LEDs of the X-300EEC

You will find the meaning of the individual LEDs in the section "LED display (Page 151)".

Ports of the X302-7EEC

The SCALANCE X302-7EEC has the following ports:

- 2 electrical gigabit ports (P8 to P9)
- 7 optical Fast Ethernet ports (P1 to P7)



Image 4-19 SCALANCE X302-7EEC

Port number	P1	P2	P3	P4	P5	P6	P7	P8	P9
Connection type	Optical: Fast Ethernet							Electrical: Gigabit Ethernet	

Ports of the X307-2EEC

The SCALANCE X307-2EEC has the following ports:

- 7 electrical ports (P3 to P9)
 - 5 Fast Ethernet ports (P3 to P7)
 - 2 gigabit ports (P8, P9)
- 2 optical Fast Ethernet ports (P1, P2)



Image 4-20 SCALANCE X307-2EEC

Port number	P1	P2	P3	P4	P5	P6	P7	P8	P9
Connection type	Optical: Fast Ethernet		Electrical: Fast Ethernet					Electrical: Gigabit Ethernet	

4.2.5 XR-300M EEC product group

4.2.5.1 Product characteristics of the SCALANCE XR324-4M EEC

Connection options with the SCALANCE XR324-4M EEC

The SCALANCE XR324-4M EEC is a partially modular device and has 24 ports.

- **16 fixed ports in the base device:**
16 RJ-45 jacks for connection of end devices or other network segments.
- **8 modular ports via module slots:**
4 modules can be combined using slots (S1-S4) depending on the application. End devices and other network segments are connected according to the modules being used.



Image 4-21 XR324-4M EEC

⚠ CAUTION												
Use only approved media modules												
If you use media modules that are not approved by Siemens AG, there is no guarantee that the device will function according to the specification.												
If you use unapproved media modules, this can lead to the following problems:												
<ul style="list-style-type: none"> • Damage to the device • Loss of the approvals • Violation of the EMC regulations 												
Use only approved media modules.												

Slot number									S1		S2	
Port number	P1	P2	P3	P4	P5	P6	P7	P8	P1	P2	P1	P2
Slot number									S3		S4	
Port number	P9	P10	P11	P12	P13	P14	P15	P16	P1	P2	P1	P2

4.2.6 Product group X-300M PoE

4.2.6.1 SCALANCE X308-2M PoE product characteristics

Possible attachments

The SCALANCE X308-2M PoE is a partially modular device and has eight ports.

- **Four fixed ports in the base device:**
Four PoE-compliant ports (RJ-45 jacks with securing collars) for connection of end devices or other network segments.
- **Four modular ports via module slots:**
Two media modules (optical or electrical as required) can be combined using slots (S1-S2) depending on the application. End devices and other network segments are connected according to the media modules being used.

Note

When shipped, the slots for the media modules have a dummy cover fitted.



Image 4-22 SCALANCE X308-2M PoE with dummy covers

Possible attachments (example)

 CAUTION
<p>Use only approved media modules in the module slots</p> <p>The connection of end devices or other network segments does not depend on the module slot, but rather on the selected media module.</p> <p>Refer to the section Media module installation in slot.</p>

Example: Fitted with media modules MM992-2 and MM991-2



Image 4-23 SCALANCE X308-2M PoE with MM992-2 and MM992-2SFP

Column	1	2	3	4
Slot number	-	-	S1	S2
Media modules used	-	-	MM992-2	MM992-2SFP
Port number	-	P1 (gigabit Ethernet)	P5 (gigabit multimode fiber-optic cable, SC ports)	P7 (interface depends on SFP used)
	-	P2 (gigabit Ethernet)		
	-	P3 (gigabit Ethernet)		
	-	P4 (gigabit Ethernet)		

4.2.7 Product group XR-300M PoE

4.2.7.1 SCALANCE XR324-4M PoE product characteristics

Connection options of the SCALANCE XR324-4M PoE and XR324-4M PoE TS switches

The switches are partly modular devices and all have 24 ports.

- **16 fixed ports on the base device:**

- Ports P1 to P8

8 PoE-compliant gigabit ports (RJ-45 jacks with securing collars) for connection of end devices or other network segments.

Non PoE-compliant end devices can also be connected to the PoE-compliant RJ-45 jacks because the switches check that the end devices are suitable for the PoE function before applying the power.

- Ports P9 to P16

8 gigabit ports (RJ-45 jacks with securing collars) for connection of end devices or other network segments (no PoE).

- **8 modular ports via 4 module slots:**

4 media modules each with 2 ports are combined optically or electrically via the slots S1 to S4 depending on the application. End devices and other network segments are connected according to the media modules being used.



Image 4-24 XR324-4M PoE and XR324-4M PoE TS

CAUTION

Use only approved modules in the slots

Possible module connection types:

- 2 x RJ-45
- 2 x FX100
- 2 x FX1000
- or 2 x SFP slots

With FX, single mode fibers or multimode fibers are possible.

Connecting end devices or other network segments does not depend on the module slots.

4.2 Product groups

Slot number									S1			S2		
Port number	P1	P2	P3	P4	P5	P6	P7	P8	P1	P2	P1	P2		
Slot number									S3			S4		
Port number	P9	P10	P11	P12	P13	P14	P15	P16	P1	P2	P1	P2		
Connection type	Electrical: Gigabit Ethernet								Connection type depending on module used					

4.2.8 MM900 media modules

4.2.8.1 MM992-2CUC product characteristics

Possible attachments

The MM992-2CUC media module has the following:

- 2 x 10/100/1000 Mbps, RJ-45 ports electrical with securing collar

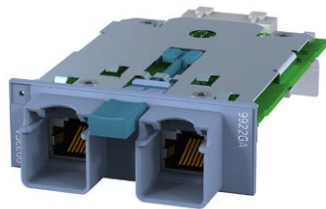

Image 4-25 MM992-2CUC [9922GA]

[Device labeling in square brackets]

Note

For connection to electrical networks note the information in Appendix A.1 and A.2.

4.2.8.2 MM992-2CU product characteristics

Possible attachments

The MM992-2CU media module has the following:

- 2 x 10/100/1000 Mbps, RJ-45 port electrical without securing collar



Image 4-26 MM992-2CU [9922SA]

[Device labeling in square brackets]

Note

For connection to electrical networks note the information in Appendix A.1 and A.2.

4.2.8.3 MM992-2VD product characteristics

Possible attachments

The MM992-2VD media module has the following:

- 2 x 10/100/1000 Mbps, RJ-45 ports electrical with securing collar
- Additional two-wire transfer function (variable distance) for establishing Ethernet connections even using cables that do not conform to Ethernet. Possible distance covered depends on the cable quality.



Image 4-27 MM992-2VD [9922VA]

[Device labeling in square brackets]

Note

For connection to electrical networks note the information in Appendix A.1 and A.2.

Pin assignment for the RJ-45 connector of a PROFIBUS cable

If you use a PROFIBUS cable along with an IE FC RJ-45 plug 4x2, note the following:

RJ-45 connectors		PROFIBUS cable
Pin assignment	Color	Wire color
1	Yellow	Green
2	Orange	Red
3	White	--
6	Blue	--

Note

Using PROFIBUS standard cable GP

If you use a PROFIBUS standard cable GP, the wires must be stripped before they are inserted in the FC connector.

Note

If you use cables with a length > 500 m, connection establishment can take up to 2 min.

Note

If you connect an MM992-2VD media module to existing PROFIBUS cabling, the same requirements relating to shield contact and the lightning protection concept apply as for PROFIBUS.

4.2.8.4 MM992-2M12 product characteristics

Possible attachments

The MM992-2M12 media module has the following:

- 2 x 10/100/1000 Mbps, GE M12 connector electrical

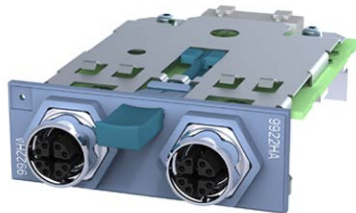

Image 4-28 MM992-2M12C [9922HA]
[Device labeling in square brackets]

Note

For connection to electrical networks note the information in Appendix (A.1, A.2 and A.3)

4.2.8.5 MM992-2SFP / MM992-2SFP (C) product properties

Note

Only the media modules MM992-2SFP / M992-2SFP (C) may be fitted with approved SFP transceivers. The SFP media modules can be fitted with up to two SFPs.

Possible attachments

The media modules MM992-2SFP / M992-2SFP (C) have:

- 2 x 100/1000 Mbps, SFP slot



Image 4-29 MM992-2SFP [9922AS]

[Device labeling in square brackets]

4.2.8.6 MM991-2 product characteristics

Possible attachments

The MM991-2 media module has the following:

- 2 x 100 Mbps, BFOC port optical (multimode, glass) up to max. 5 km



Image 4-30 MM991-2 [9912AB]

[Device labeling in square brackets]

4.2.8.7 MM991-2FM product characteristics

Possible attachments

The MM991-2FM media module has the following:

- 2 x 100 Mbps, BFOC port optical (multimode, glass) with diagnostics up to max. 5 km



Image 4-31 MM991-2FM [9912AB]

[Device labeling in square brackets]

4.2.8.8 MM991-2LD product characteristics

Possible attachments

The MM991-2LD media module has the following:

- 2 x 100 Mbps, BFOC port optical, (single mode glass), up to max. 26 km



Image 4-32 MM991-2LD [9912AC]

[Device labeling in square brackets]

4.2.8.9 MM991-2 (SC) product characteristics

Possible attachments

The MM991-2 (SC) media module has the following:

- 2 x 100 Mbps, SC port optical, (multimode glass), up to max. 5 km



Image 4-33 MM991-2 (SC) [9912AD]

[Device labeling in square brackets]

4.2.8.10 MM991-2LD (SC) product characteristics

Possible attachments

The MM991-2LD (SC) media module has the following:

- 2 x 100 Mbps, SC port optical, (single mode glass), up to max. 26 km



Image 4-34 MM991-2LD (SC) [9912AF]

[Device labeling in square brackets]

4.2.8.11 MM991-2LH+ (SC) product characteristics

Possible attachments

The MM991-2LH+ (SC) media module has the following:

- 2 x 100 Mbps, SC port optical, (single mode glass), up to max. 70 km



Image 4-35 MM991-2LH+ (SC) [9912AE]

[Device labeling in square brackets]

4.2.8.12 MM991-2P product characteristics

Possible attachments

The MM991-2P media module has the following:

- 2 x 100 Mbps SC RJ ports optical for Plastic Optical Fiber (POF) up to max. 50 m or Polymer Cladded Fiber (PCF) up to max. 100 m

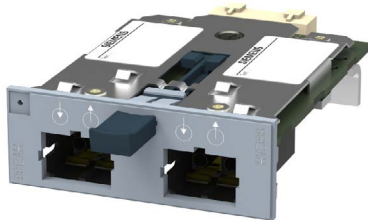

Image 4-36 MM991-2P [9912AH]

[Device labeling in square brackets]

Note**Installation of the XR-300M, XR-300M PoE and XR-300M EEC**

Only the lower slots may be equipped with the MM991-2P.

- XR-300M: Maximum 6 modules in slots 7 to 12
- XR-300M PoE, XR-300M EEC: Maximum 2 modules in slots 3 and 4

The slot above an MM991-2P may only be used as follows:

- Without media module
- With media module MM992-2CUC or MM992-2CU

Example XR-300M: If the MM991-2P is plugged into slot 8, an MM992-2CUC may be used in slot 2.

See also table: "Operating temperature with media module MM991-2P"

4.2.8.13 MM992-2 product characteristics

Possible attachments

The MM992-2 media module has the following:

- 2 x 1000 Mbps, SC port optical, (multimode glass), up to max. 750 m



Image 4-37 MM992-2 [9922AL]

[Device labeling in square brackets]

4.2.8.14 MM992-2LD product characteristics

Possible attachments

The MM992-2LD media module has the following:

- 2 x 1000 Mbps, SC port optical, (single mode glass), up to max. 10 km



Image 4-38 MM992-2LD [9922AM]

[Device labeling in square brackets]

4.2.8.15 MM992-2LH product characteristics

Possible attachments

The MM992-2LH media module has the following:

- 2 x 1000 Mbps, SC port optical, (single mode glass), up to max. 40 km

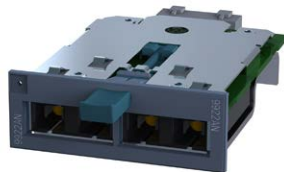

Image 4-39 MM992-2LH [9922AN]

[Device labeling in square brackets]

4.2.8.16 MM992-2LH+ product characteristics

Possible attachments

The MM992-2LH+ media module has the following:

- 2 x 1000 Mbps, SC port optical, (single mode glass), up to max. 70 km

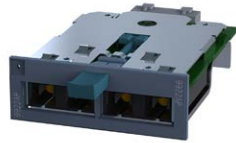

Image 4-40 MM992-2LH+ [9922AP]

[Device labeling in square brackets]

4.2.8.17 MM992-2ELH product characteristics

Possible attachments

The MM992-2ELH media module has the following:

- 2 x 1000 Mbps, SC port optical, (single mode glass), up to max. 120 km

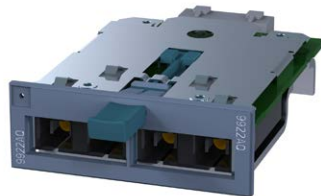

Image 4-41 MM992-2ELH [9922AQ]

[Device labeling in square brackets]

4.2.8.18 General notes on MM900





Note

Use media modules only in an approved modular device ("M")

Use an MM900 media module only in a device equipped with suitable slots for such modules. Example: X308-2M.

The MM900 media module decides what can be connected

The connection of end devices or other network segments does not depend on the module slot, but rather on the selected MM900 media module.

Possible attachment	Figure
Electrical RJ-45 ports with securing collar	
Electrical RJ-45 ports without securing collar	
GE M12 connector electrical	
BFOC ports optical	
Optical SC ports	
SFP transceivers Only the SFP media module MM992-2SFP may be fitted with approved SFP transceivers. The SFP media module can be fitted with up to two SFPs.	
SC RJ ports optical	

4.2.9 SFP transceiver

4.2.9.1 SCALANCE SFP991-1 product characteristics

Possible attachments

The **SFP991-1** transceiver has the following:

- 1 x 100 Mbps, LC port optical (multimode, glass) up to max. 3 km



Image 4-42 SFP991-1

4.2.9.2 SCALANCE SFP991-1LD product characteristics

Possible attachments

The **SFP991-1LD** transceiver has the following:

- 1 x 100 Mbps, LC port optical (single mode, glass) up to max. 26 km



Image 4-43 SFP991-1LD

4.2.9.3 SCALANCE SFP991-1LH+ product characteristics

Possible attachments

The **SFP991-1LH+** transceiver has the following:

- 1 x 100 Mbps, LC port optical (single mode, glass) up to max. 70 km

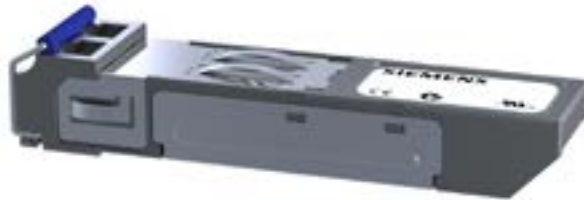

Image 4-44 SFP991-1LH+

4.2.9.4 SCALANCE SFP992-1 product characteristics

Possible attachments

The **SFP992-1** transceiver has the following:

- 1 x 1000 Mbps, LC port optical (multimode, glass) up to max. 750 m



Image 4-45 SFP992-1

4.2.9.5 SCALANCE SFP992-1LD product characteristics

Possible attachments

The **SFP992-1LD** transceiver has the following:

- 1 x 1000 Mbps, LC port optical (single mode, glass) up to max. 10 km



Image 4-46 SFP992-1LD

4.2.9.6 SCALANCE SFP992-1LH product characteristics

Possible attachments

The **SFP992-1LH** transceiver has the following:

- 1 x 1000 Mbps, LC port optical (single mode, glass) up to max. 40 km



Image 4-47 SFP992-1LH

4.2.9.7 SCALANCE SFP992-1LH+ product characteristics

Possible attachments

The **SFP992-1LH+** transceiver has the following:

- 1 x 1000 Mbps, LC port optical (single mode, glass) up to max. 70 km



Image 4-48 SFP992-1LH+

4.2.9.8 SCALANCE SFP992-1ELH product characteristics

Possible attachments

The **SFP992-1ELH** transceiver has the following:

- 1 x 1000 Mbps, LC port optical (single mode, glass) up to max. 120 km



Image 4-49 SFP992-1ELH

4.2.9.9 General notes on SFP

Note

Only the media module MM992-2SFP may be fitted with approved SFP transceivers. The SFP media module can be fitted with up to two SFPs.

Device: Media module	(Variant)	[Order number] Labeling on the device	Figure
MM992-2SFP	(2 x 100/1000 Mbps, SFP media module)	[6GK5 992-2AS00-8AA0] 9922AS	

Note

An SFP with multimode has a black clip and an SFP with single mode has a blue clip. To protect the pins, these are fitted with a dummy plug.

4.2.9.10 Supported wavelengths of the SFPs

Pluggable transceiver		Supported wavelength
SFP	SFP991-1	1310 nm
	SFP991-1 (C)	
	SFP991-1LD	
	SFP991-1LD (C)	
	SFP991-1LH+	1550 nm
	SFP991-1ELH200	
	SFP992-1	850 nm
	SFP992-1LD	1310 nm
	SFP992-1LD (C)	
	SFP992-1LH	
	SFP992-1LH+	1550 nm
	SFP992-1ELH	
SFP+	SFP993-1	850 nm
	SFP993-1LD	1310 nm
	SFP993-1LH	1550 nm

SCP	SCP992-1	850 nm
	SCP992-1LD	1310 nm
STP	STP991-1	1310 nm
	STP991-1LD	

4.3 Interfaces and signaling contact of the switches

4.3.1 Ethernet interfaces - electrical ports

4.3.1.1 10Base-T / 100Base-TX

Transmission rate

The transmission rate of the electrical ports is 10 Mbps or as Fast Ethernet ports 100 Mbps.

Transmission mode

The transmission mode for 10Base-T / 100Base-TX is specified in the IEEE 802.3i / IEEE 802.3u standards of the Institute of Electrical and Electronic Engineers.

Autonegotiation (automatic detection of the best transmission modes) is default. The order in which they are selected is:

- 100Base-TX full duplex
- 100Base-TX half duplex
- 10Base-T full duplex
- 10Base-T half duplex

Two communication modes are possible:

- Half duplex
Two-way alternate transmission mode - it is only possible to either send or receive over the interfaces at any one time.
- Full duplex mode
Two-way simultaneous - both communication partners can send and receive at the same time.

Connections to other switches can use half or full duplex; connections to hubs are possible only in half duplex mode.

4.3 Interfaces and signaling contact of the switches

Transmission medium

Data transmission at 10 Mbps and at 100 Mbps is over two wire pairs (pin 1, 2, 3, 6) of the twisted pair cable. For 10 Mbps, at least a category 3 (Cat 3) and for 100 Mbps, at least a four-wire (2 x 2) category 5 (Cat 5) cable is necessary.

Transmission range

The maximum transmission range (segment length) is 100 m.

Connectors

A node or network segment is connected to an 8-pin RJ-45 jack with securing collar. Due to its flush fitting with an IE FC RJ-45 Plug 180 / IE FC RJ45 Plug 145 connector, the securing collar ensures a robust connection suitable for industry that provides tensile and bending strain relief for the inserted connector.

Note

The RJ-45 jacks of the SCALANCE X300EEC variants do not have a securing collar. The tensile and bending relief are provided by the securing bracket using a cable binder, see also section Signaling contact (Page 145).

4.3.1.2 1000Base-T

Transmission rate

The transmission rate of the electrical Ethernet ports is 10 Mbps, as Fast Ethernet ports 100 Mbps or as gigabit ports 1 Gbps.

Transmission mode

The transmission mode for 1000Base-T is specified in the IEEE 802.3ab standard.

Autonegotiation (automatic detection of the best transmission mode) is default.

The order in which they are selected is:

- 1000Base-T full duplex
- 1000Base-T half duplex
- 100Base-TX full duplex
- 100Base-TX half duplex
- 10Base-T full duplex
- 10Base-T half duplex

Two communication modes are possible:

- Half duplex
Two-way alternate transmission mode - it is only possible to either send or receive over the interfaces at any one time.
- Full duplex mode
Two-way simultaneous - both communication partners can send and receive at the same time.

Transmission medium

Data is transmitted over an eight-wire twisted pair cable.

Note

For data transmission at 1 Gbps, at least a Cat 5e twisted-pair cable with 4 x 2 wires is necessary. With a four-wire cable (2 x 2 wires), a maximum data transmission rate of 100 Mbps is possible.

Transmission range

The maximum transmission range (segment length) is 100 m.

Connectors

The connectors used are 8-pin RJ-45 jacks.

4.3.1.3 Power over Ethernet (PoE)

Power over Ethernet (PoE)

With PoE, the power for networked devices is carried via Ethernet. Here, there are two methods of supplying power:

- Alternative A

Here, the voltage is transferred on the data wires 1, 2, 3 and 6 of the Ethernet cable

Requirements for the Ethernet cable:

- For 10Base-T/100Base-TX, a 4-wire cable is adequate for data transmission and power supply.
- With 1000BASE-T, an 8-wire cable is necessary for data transmission.

- Alternative B

Power is transferred on the free wires 4, 5, 7 and 8 of the Ethernet cable.

Requirements for the Ethernet cable: For 10Base-T/100Base-TX/1000BASE-T, an 8-wire cable is needed.

4.3 Interfaces and signaling contact of the switches

PoE-compliant devices can be divided into the following groups:

- PSE - power sourcing equipment
These inject power onto the Ethernet cable.
- PD - powered devices
These are supplied with power via Ethernet.

4.3.1.4 Ports of the X308-2M PoE

The PoE ports of the switch

As a PSE, the X308-2M PoE supplies PoE-compliant devices with power over Ethernet. The 48 V power required to supply the powered devices is generated internally on the switch, no extra power supply unit is necessary.

The X308-2M PoE uses the "alternative A" for this. Per RJ-45 port, a maximum of 15.4 W are available for supplying a PoE-compliant device. If a Cat5/Cat5e cable with a maximum length of 100 m is used, the connected device can be supplied with a power of 12.95 W.

Note

The total power provided by the SCALANCE X308-2M PoE on all four PoE ports is a maximum of 30.8 W.

The PoE ports meet the conditions listed in the IEEE 802.3af / IEEE 802.3at standard (type 1) for environment A, in other words power supply over Ethernet within a power supply system. For details of configuring and enabling PoE for individual ports, refer to the configuration manual SCALANCE X-300 / X-400 on the accompanying CD.

Possible attachments

The X308-2M PoE is a partially modular device and has 4 fixed ports and 2 slots for media modules.

- **4 electrical ports**

4 PoE-compliant RJ-45 jacks with securing collars for connection of end devices or network segments. Non PoE-compliant end devices can also be connected to the PoE-compliant RJ-45 jacks because the X308-2M PoE checks that the end devices are suitable for the PoE function before applying the power.

- **4 modular ports via 2 module slots**

2 media modules each with 2 ports are combined optically or electrically via the slots S1 and S2 depending on the application.

End devices and other network segments are connected according to the media modules being used.

4.3.1.5 PoE ports

PoE ports of the SCALANCE XR324-4M PoE and XR324-4M PoE TS switches

As PSEs, these devices supply PoE-compliant devices with power over Ethernet. The power required to supply the powered devices is generated internally on the switches, no extra power supply unit is necessary.

The switches use the "Alternative A" method. Per RJ-45 port, a maximum of 15.4 W are available for supplying a PoE-compliant device. If a Cat5/Cat5e cable with a maximum length of 100 m is used, the connected device can be supplied with a power of 12.95 W.

Note

The total power provided by the switches on all eight PoE ports is a maximum of 53.2 W.

The PoE ports meet the conditions listed in the IEEE 802.3af / IEEE 802.3at standard (type 1) for environment A , in other words power supply over Ethernet within a power supply system. For details of configuring and enabling PoE for individual ports, refer to the configuration manual SCALANCE X-300 / X-400 on the accompanying CD.

4.3.1.6 Isolation between the TP ports

All ports meet the requirement of 1.5 kV isolation voltage to the shield and between the ports (corresponds to IEEE802.3, Environment B).

Note

Exceptions are X307-3, X307-3LD, X308-2, X308-2LD, X308-2LH, X308-2LH+, X310, X310FE

The following port group is an exception to this:

- Port group 1: P1, P2, P3 and P4

Between the ports of port group 1, the requirements for Environment A are met.

4.3.2 Ethernet interfaces - optical ports

4.3.2.1 1000Base-SX

Transmission rate

The transmission rate of the optical gigabit ports is 1 Gbps.

4.3 Interfaces and signaling contact of the switches

Transmission mode

Transmission with 1000Base-SX is defined in the IEEE 802.3z standard and is specified as 1000 Mbps transmission rate and full duplex.

Transmission medium

Data is transmitted over multimode FOC. The wavelength is 850 nm.

The core diameter of the multimode FOC is 50 µm; the light source is an LED. Many modes (light beams) are used for signal transmission. The propagation times of the light pulses (dispersion) restrict the maximum range considerably.

Transmission range

The maximum transmission range (segment length) is 750 m when using SIMATIC NET fiber-optic multimode FOC with SC duplex connectors.

Connectors

SC duplex female connectors are used.

On the IE Switches X-300EEC, devices are connected via LC jacks.

4.3.2.2 1000Base-LX / 100Base-FX

Transmission rate

The transmission rate of the optical gigabit ports is 1 Gbps.

Transmission mode

Transmission with 1000Base-LX is defined in the IEEE 802.3z standard and is specified as 1000 Mbps transmission rate and full duplex.

Transmission medium

Data is transmitted over single mode FOC. The wavelength is 1310 nm or 1550 nm.

The core diameter of the single mode FO cable is 9 or 10 µm; the light source is a laser diode. To transmit a signal, only one mode (light beam) is used greatly reducing dispersion. As a result, the maximum range of single mode FOC is greater than that of multimode FOC.

Transmission range

The maximum transmission distance (segment length) is 120 km for 1000Base-LX transmission.

IE Switches X-300 connector technology

SC duplex female connectors are used.

Connector technology of the IE Switch X-300EEC

FC duplex female connectors with the following characteristics are used:

- Maximum range: up to 3 km
- Wavelength: 1310 nm
- Transmission mode: Multimode
- Standard: 100Base-FX

4.3.3 Signaling contact

The signaling contact (relay contact) is a floating switch with which error/fault states can be signaled by breaking the contact.

Error indication

- The signaling by the signaling contact is synchronized with the fault LED, in other words, all errors displayed by this LED (freely configurable) are also signaled on the signaling contact.
- If an internal fault occurs, the fault LED lights up and the signaling contact opens.
- The connection or disconnection of a communication node on an unmonitored port does not lead to an error message.
- The signaling contact remains activated until the error/fault is eliminated or until the current status is entered in the fault mask as the new desired status.

4.4 C-PLUG (configuration plug)

NOTICE
DO NOT REMOVE C-PLUG WHILE POWER IS ON The C-PLUG may only be removed or inserted when the power supply to the device is turned off. In a device with a varnished printed circuit board, you may only use a C-PLUG with a varnished board.

Area of application

The C-PLUG is an exchangeable medium for storage of the configuration data of the IE Switch and ships with the product. This means that the configuration data remains available if the IE Switch is replaced.

How it works

Power is supplied by the IE Switch. The C-PLUG retains all data permanently when the power is turned off.

If an empty C-PLUG (factory settings or deleted with the Clean function) is inserted, all the configuration data of the IE Switch is saved to it automatically when the device starts up. Changes to the configuration during operation without operator intervention are saved on the C-PLUG if this is in the "ACCEPTED" status.



An IE Switch with an accepted C-PLUG inserted uses the configuration data of the C-PLUG automatically when it starts up. Acceptance is possible only when the data was written by a compatible device type.

This allows an IE Switch to be replaced quickly and simply. The C-PLUG is taken from the failed component and inserted in the replacement. The first time it is started up, the replacement device has the same configuration as the failed device except for the MAC address set by the vendor.

Diagnostics

Inserting a C-PLUG that does not contain the configuration of a compatible device type, accidentally removing the C-PLUG or general malfunctions of the C-PLUG are signaled by the diagnostics mechanisms of the IE Switch (LEDs, WEB-based management, SNMP, CLI and PROFINET diagnostics).

Inserting in the C-PLUG slot on the IE Switch X-300



Product group	Slot	Figure	C-PLUG
X-300 X-300M	Rear of the device		<ol style="list-style-type: none"> 1. Remove the screw cover. 2. Insert the C-PLUG in the intended slot. 3. Close the screw cover again correctly.
XR-300M	Rear of the device - right		<ol style="list-style-type: none"> 1. Remove the cover. 2. Insert the C-PLUG in the intended slot. 3. Close the cover again correctly.
X-300EEC	Top of the housing		<ol style="list-style-type: none"> 1. Open the slider. 2. Insert the C-PLUG. 3. Close the slider.

4.4 C-PLUG (configuration plug)

Removing the C-PLUG from the IE Switch X-300

It is only necessary to remove the C-PLUG if the IE Switch develops a fault.

The C-PLUG can be removed from the slot using flat pliers, tweezers, or a small screwdriver.

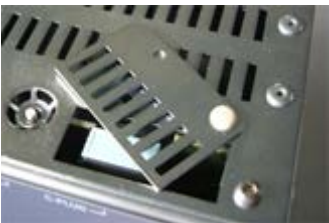
Product group	Slot	Figure	
X-300 X-300M	Rear of the device		<ol style="list-style-type: none"> 1. Remove the screw cover. 2. Remove the C-PLUG. 3. Close the screw cover again correctly.
XR-300M	Rear of the device - right		<ol style="list-style-type: none"> 1. Remove the cover. 2. Remove the C-PLUG. 3. Close the cover again correctly.
X-300EEC	Top of the housing		<ol style="list-style-type: none"> 1. Open the slider. 2. Remove the C-PLUG. 3. Close the slider.

4.5 Components of the product

Unpacking, checking

1. Make sure that the package is complete.
2. Check all the parts for transport damage.

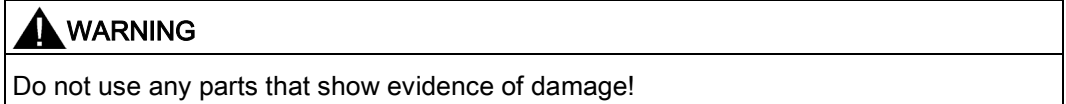

4.5.1 Components of the product

The following components are supplied with a SCALANCE X-300:

- Device with C-PLUG exchangeable medium.
- A four-pin terminal block for the 24 VDC power supply.
- A two-pin terminal block for the signaling contact.
- Product CD with documentation and software.

4.5.2 X-300M components of the product

Note

When shipped, all devices have a C-PLUG exchangeable medium.

Note

When shipped, the slots for the media modules have a dummy cover fitted.

Note

Labels to identify the installed MM900 media modules are supplied with the modular devices (M).

4.5 Components of the product

Table 4- 1 Overview of the components shipped with the X-300M product group

Device: SCALANCE	Variant	Plug-in terminal block		Device	BAK	Product CD
		Signaling contact	Power supply			
X308-2M	(-)	2-pin	4-pin (24 V)	•	•	•
X308-2M TS	(-)	2-pin	4-pin (12 V)	•	•	•

4.5.3 Components of the XR-300M product

Note

When shipped, the slots for the media modules have dummy covers fitted.

Note

Labels to identify the installed MM900 media modules are supplied with the modular devices (M).

The following parts ship with a SCALANCE XR-300M:

- Device with C-PLUG exchangeable medium.
- 2 mounting brackets and 8 screws (M3x5 recessed head, drive: Torx) for 19" rack installation.
- A two-pin terminal block for the signaling contact.
- Connecting cable for the diagnostics port.
- Adhesive feet for desktop operation.
- Product CD with documentation and software.

For devices with a 100 to 240 VAC power supply also:

- A two-pin connector for the power supply.

For devices with a 24 VDC power supply, also:

- A four-pin terminal block for the power supply.

4.5.4 X-300EEC product components

Apart from the device itself, the following components are also supplied with the switch:

Table 4- 2 Overview of the components shipped with the X-300EEC product group

Device: SCALANCE (variants)	Components of the product				
	C-PLUG	Plug-in terminal block	Power		Product CD
			Signaling contact with contact pins	DC 24 to 48 V	
X302-7EEC					
1 x power supply unit 24 VDC,	•	1 x 2-pin	1 x 4-pin	-	•
2 x power supply unit 24 VDC	•	2 x 2-pin	2 x 4-pin	-	•
1 x power supply unit 100 to 240 VAC / 60 to 250 VDC	•	1 x 3-pin	-	1 x 3-pin	•
2 x power supply unit 100 to 240 VAC / 60 to 250 VDC	•	2 x 3-pin	-	2 x 3-pin	•
X307-2EEC					
1 x power supply unit 24 VDC	•	1 x 2-pin	1 x 4-pin	-	•
2 x power supply unit 24 VDC	•	2 x 2-pin	2 x 4-pin	-	•
1 x power supply unit 100 to 240 VAC / 60 to 250 VDC	•	1 x 3-pin	-	1 x 3-pin	•
2 x power supply unit 100 to 240 VAC / 60 to 250 VDC	•	2 x 3-pin	-	2 x 3-pin	•

4.5.5 Components of the XR-300M EEC product

Note

- When shipped, all devices have a C-PLUG exchangeable medium.
- When shipped, the slots for the media modules have a dummy cover fitted.
- Labels to identify the installed MM900 media modules are supplied with the modular devices.

The consignment of a SCALANCE XR-300M EEC consist of the device itself and the following parts:

- 2 mounting brackets and 8 screws (M3x5 recessed head, drive: Torx) for 19" rack installation
- Connecting cable for the diagnostics port
- Operating Instructions (compact) SCALANCE XR-300 M EEC.

4.5 Components of the product

- With devices with power supply 100 to 240 VAC / 60 to 250 VDC:
 - A 3-pin terminal block (or two terminal blocks for redundant power supply) for the signaling contacts.
 - A 3-pin terminal block (or two terminal blocks for redundant power supply) for the power supply.
- With devices with 24 to 48 VDC power supply:
 - A 2-pin terminal block (or two terminal blocks for redundant power supply) for the signaling contacts.
 - A 4-pin terminal block (or two terminal blocks for redundant power supply) for the power supply.

4.5.6 Components of the X308-2M PoE product

Interfaces

Type	RJ-45 port electrical 10/100/1000 Mbps	Module slots
X308-2M PoE	4	2

Components of the product

The following parts ship with a SCALANCE X-300M PoE:

- Device with C-PLUG exchangeable medium
- 4-pin terminal block for the power supply
- 2-pin terminal block for the signaling contact
- Product CD with documentation and software

Order numbers

Type	Order number
X308-2M PoE	6GK5 308-2QG00-2AA2

4.5.7 Components of the XR-324-4M PoE product

Components that ship with the SCALANCE XR324-4M PoE and XR324-4M PoE TS switches

The following components ship with a SCALANCE XR324-4M PoE or XR324-4M PoE TS:

- Device with C-PLUG exchangeable medium
- 2 mounting brackets and 8 screws (M3x5 recessed head, drive: Torx) for 19" rack installation
- Connecting cable for the diagnostics port
- Product CD with documentation and software
- For devices with a 100 to 240 VAC power supply:
 - A 2-pin terminal block for the power supply
 - A 2-pin terminal block for the signaling contact
- With devices with 24 V DC power supply:
 - 4-pin terminal block for the power supply
 - 2-pin terminal block for the signaling contact
 - 4 adhesive feet for desktop mounting

4.5.8 Components shipped with the MM900 product

The following components are supplied with a SCALANCE MM900 media module:

- MM99x-2xx media module

Note

Identification labels

The location labels identify the media modules and ship with the SCALANCE device.

4.5.9 Components shipped with the SFP product

Table 4- 3 Overview of the components shipped with the SFP product group

Device: Transceiver	(Variant)	Plug-in terminal block		Device	Product CD
		(signaling contact) 2-pin	(24V) 4-pin		
SFP991-1	(-)	-	-	•	-
SFP991-1LD	(-)	-	-	•	-
SFP991-1LH+	(-)	-	-	•	-

4.5 Components of the product

Device: Transceiver	(Variant)	Plug-in terminal block		Device	Product CD
		(signaling contact) 2-pin	(24V) 4-pin		
SFP992-1	(-)	-	-	•	-
SFP992-1LD	(-)	-	-	•	-
SFP992-1LH	(-)	-	-	•	-
SFP992-LH+	(-)	-	-	•	-
SFP992-1ELH	(-)	-	-	•	-

You will find detailed instructions on connecting up the power supply and the signaling contact in the section Connecting (Page 127).

 WARNING
Installation guidelines and safety notices When installing and operating the device, keep to the installation instructions and safety-related notices as described here (section Safety instructions (Page 15)) and in the manual SIMATIC NET Industrial Ethernet Twisted Pair and Fiber Optic Networks (see Preface (Page 3)). Installation location and temperatures above 55 °C When installing the device, select a location where only qualified service personnel or trained users have access to it. If the device is operated in an ambient temperature of more than 55 °C, the temperature of the device housing may be higher than 70 °C. Provide suitable shade to protect the IE Switch X-300 against direct sunlight. This avoids unnecessary warming of the IE Switches X-300 and prevents premature aging of the IE Switch X-300 and cabling. Use of approved components <ul style="list-style-type: none">• Use only approved components, for example supporting brackets, SFPs, 19 inch racks.• Create any supports you require according the drawings in section Graphics (Page 283).

Note

Suitable spare parts

You will find the list with the spare parts on the pages of Siemens Industry Automation Customer Support under the following entry ID: 60700974 (<http://support.automation.siemens.com/WW/view/en/60700974>)

Unless stated otherwise, the mounting options listed below apply to all IE Switch X-300.

Mounting position of the IE Switch X-300EEC

NOTICE
Only the normal mounting position with the cable outlets downwards is permitted.

Minimum clearances

If you install the IE Switch X-300EEC in enclosures without forced ventilation or cooling, minimum clearances must be maintained to neighboring devices or the wall of the enclosure. By keeping to the minimum clearances, there is then an adequate stream of air for heat dissipation during operation. Keep to the following minimum clearances to neighboring devices.

Table 5- 1 Minimum clearances when installing the X-300EEC

Minimum clearance to devices below the switch	100 mm
Minimum clearance to devices above the switch	100 mm
Minimum clearance at the sides	20 mm

5.1 Overview of the methods of installation

Installing the switches

IE Switches X-300 can be installed in various ways:

- Installation on a 35 mm DIN rail
- Installation on a SIMATIC S7-300 standard rail
- Wall mounting
- 19" rack mounting (SCALANCE XR300)

For the possible types of installation, refer to section Technical specifications (Page 155)

Note

Standard rail and wall mounting of the IE Switch X-300EEC

With the X-300EEC, note the special features in the relevant subsection on standard rail or wall mounting.

Media modules and SFP transceivers

Media modules and SFP transceivers are used in modular devices.

- Media modules are used in the appropriate slots of the switch.
- SFP transceivers are used only in SFP media modules.

5.2 Installing a switch

CAUTION

Electrical connections

Make sure that the power supply of the switch is turned off when fitting the connectors for the power supply and the signaling contacts.

For information on the electrical connections, refer to Section Connecting (Page 127).

5.2.1 Installation on a DIN rail

WARNING

No installation on a 35 mm DIN rail in shipbuilding

In ships, the 35 mm DIN rail does not provide adequate support.

This applies to all devices with this notice in the "Installation options" table in the section "Technical specifications" (subsection, "Construction, installation and environment").

Installation

Install the IE Switch X-300 on a 35 mm DIN rail complying with DIN EN 60715.

1. Hang the IE Switch X-300 on the DIN rail and then push it in against the rail until it clips into place.
2. Connect the grounding of the switch according to the description in the section Connecting the grounding (Page 130).
3. Fit the connectors for the power supply.
4. Fit the connectors for the signaling contact.
5. Insert the terminal blocks into the sockets on the IE Switch X-300.



Image 5-1 Mounting an IE Switch X-300 on a DIN rail (35 mm)

Uninstalling

To remove an IE Switch X-300 from the DIN rail:

1. Disconnect all cables from the switch.
2. Release the lower part of the IE Switch X-300 from the DIN rail with a screwdriver and pull the lower part of the switch away from the DIN rail.



Image 5-2 Removing an IE Switch X-300 from a DIN rail (35 mm)

DIN rail mounting of the IE Switch X-300EEC

⚠ CAUTION

Grounding

The device is grounded via the bolts in the floor of the housing. Grounding via the DIN rail alone is not adequate.

On the X-300EEC with power supply 100...240 V AC, you must always connect protective ground via the bolts on the bottom of the device housing.

Removing the IE Switch X-300EEC

1. Push the X-300EEC down.
 2. Swing the device upwards.
- No tools are necessary for removing the device.

5.2.2 Installation on a standard rail

Installation on a SIMATIC S7-300 standard rail

1. Hang the upper guide at the top of the switch housing onto the S7 standard rail.
2. Screw the IE Switch X-300 to the underside of the standard rail.
3. Connect the grounding of the switch according to the description in the section Connecting the grounding (Page 130).
4. Connect the power supply to the appropriate terminal block.

5. Connect the cable for the signaling contact to the appropriate terminal block.
6. Insert the terminal blocks into the sockets on the IE Switch X-300.

Note**Standard rail mounting of the IE Switch X-300EEC**

The IE Switch X-300EEC can only be mounted on an S7-300 standard rail using a commercially available adapter.



Image 5-3 Installing an IE Switch X-300 on a SIMATIC S7-300 standard rail

⚠ CAUTION**Grounding of the X-300EEC**

The device is grounded via the bolts in the floor of the housing.

On the X-300EEC with power supply 100...240 V AC, you must always connect protective ground via the bolts on the bottom of the device housing.

Uninstalling

To remove an IE Switch X-300 from the SIMATIC S7-300 standard rail, follow these steps:

1. Disconnect all connected cables.
2. Loosen the screws on the underside of the standard rail and lift the IE Switch X-300 away from the rail.

5.2.3 Wall mounting

Wall mounting

Note**Installation fittings**

When mounting on a wall, use mounting fittings suitable for the type of wall. For example, to secure to concrete:

- 4 wall plugs, 6 mm in diameter and 30 mm long
- 4 screws 3.5 mm in diameter and 40 mm long

The wall mounting must be capable of supporting at least four times the weight of the IE Switch X-300.

1. Mount the switch on the wall.
2. Connect the grounding of the switch according to the description in the section Connecting the grounding (Page 130).
3. Connect the power supply to the appropriate terminal block.
4. Connect the cable for the signaling contact to the appropriate terminal block.
5. Insert the terminal blocks into the sockets on the IE Switch X-300.

 CAUTION
--

Grounding of the X-300EEC

The device is grounded via the bolts in the floor of the housing.

On the X-300EEC with power supply 100...240 V AC, you must always connect protective ground via the bolts on the bottom of the device housing.
--

Note

For precise dimensions, refer to the dimension drawings in section Graphics (Page 283).

Note**Wall mounting of a rack device**

For wall mounting of a rack device (R), use suitable fittings such as a mounting bracket.

Wall mounting of the IE Switch X-300EEC

To mount the IE Switch X-300EEC on a wall, you require an additional securing bracket. You will find the dimensions for a suitable securing bracket in section Graphics (Page 283).

5.2.4 19" rack mounting

<p> WARNING</p> <p>Use of approved components</p> <ul style="list-style-type: none"> • Use only approved 19" cabinets. • Use only supplied mounting brackets. <p>There are several ways of fixing the mounting brackets depending on the mounting position required.</p>

19" rack mounting

19" rack mounting is possible for all rack devices identified by (XR). Refer to the technical specifications, Installation options table for each product group. The rack device (R) is installed using two mounting brackets fitted to the front. After fitting the two mounting brackets, the rack device can then be installed in a 19" cabinet.

<p>NOTICE</p> <p>Do not cover the ventilation grilles</p> <p>During installation, select a mounting position so that the ventilation grilles are always free to achieve adequate cooling. With normal orientation, the ventilation grilles are on the top, bottom and sides of the housing.</p> <p>If you install more than one rack device, make sure that the permitted ambient conditions are met for all devices in the rack.</p>

Minimum clearances

If you install the IE Switch in rack devices without forced ventilation or cooling, minimum clearances must be maintained to neighboring devices or the wall of the enclosure. By keeping to the minimum clearances, there is then an adequate stream of air for heat dissipation during operation. Keep to the following minimum clearances to neighboring devices.

Table 5- 2 Minimum clearances for installation in rack devices

Minimum clearance to devices below the switch	100 mm
Minimum clearance to devices above the switch	100 mm
Minimum clearance between two SCALANCE XR-300s at an ambient temperature up to 70 °C without external ventilation	100 mm
Minimum clearance between two SCALANCE XR-300s at an ambient temperature up to 60 °C without external ventilation	45 mm (1 height unit)

NOTICE

Four-point mounting

If mechanical load is high, the device should be secured at four points. You will find more detailed information in the section "Mechanical stability in operation".

Normal orientation

Normal orientation of the device



- The LED display is on the left of the front panel of the housing.
- To the right of the LED display, the SCALANCE XR-300 has connectors for the signaling contacts and the power supply. Note that the SCALANCE XR-300 is available for different power supplies (100 to 240 VAC and 24 VDC variants).
- The Ethernet ports or the slots for the modules are also on the front of the housing. Slots for the modules are fitted with dummy covers.
- The C-PLUG is on the right behind a protective panel secured with screws.
(For more detailed information, refer to the section on the C-PLUG in the X-300 operating instructions.)
- The ventilation grilles are on the top, bottom and sides of the housing.

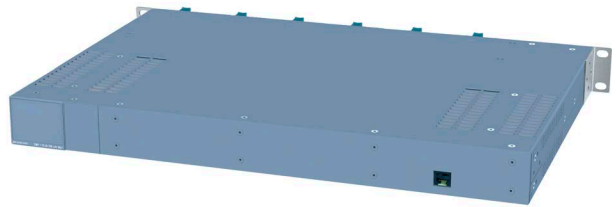

- On the back of the housing, you will find the diagnostics port of the device. (For more details, refer to Diagnostics port XR-300.) On the SCALANCE X-300M EEC, you will also find the connectors for the signaling contacts and power supply here.



19" rack mounting with normal orientation

19" rack mounting	
1.	Select the required rack device (R) and the 19" cabinet.
2.	Fix the two mounting brackets with 4 screws each to the sides of the housing. The maximum tightening torque for these screws is 0.5 Nm. 
	<p>CAUTION: If you install a rack device (R) with components inserted.</p> <p>The locking mechanisms of components installed in the rack device (R) (for example the handles of media modules or the clips on the SFP) must be closed.</p> <p>See also installation of modular devices:</p> <ul style="list-style-type: none"> - Installing media modules in a slot - Installing an SFP in an SFP media module. 
3.	Insert the rack device (R) in the 19" cabinet and hold the rack device (R) at the required height. Make sure that nothing is obstructing air from entering the ventilation grilles.
	Fit the securing screws to the two mounting brackets to secure the rack device (R) in the 19" cabinet.
4.	Connect the grounding bolts. On the SCALANCE X-300EEC, the PE connector is on the bottom of the device. On the SCALANCE XR-300M EEC, the PE connector is on the rear of the device between the power connectors.
5.	Fit the connectors for the power supply. Note that the SCALANCE X-300 is available for different power supplies (100 to 240 VAC and 24 VDC variants).
6.	Fit the remaining connectors, for example the signaling contact.

Example of individual installation

Note



Individual installation of the SCALANCE XR-300M

Devices of the XR-300M category can also be installed upright in a cabinet door. In this case, the LED display is at the front and the data cable outlet at the back at the cabinet door.

Make sure that the mounting bracket is correctly positioned on the rack device (R) so that the rack device (R) can be mounted securely on the cabinet door.

Desktop operation (only 24 V DC variants with adhesive feet)

 CAUTION
<p>No desktop operation for devices with 100 to 240 V AC power supply</p> <p>Desktop operation is permitted only for the 24 VDC variants of the rack devices (R). The adhesive feet ship with the 24 VDC variants. The permitted ambient temperature for desktop operation is -40 °C to +50 °C.</p>

Desktop operation (only 24 VDC variants with adhesive feet)		
1.	Select the required 24 V variant of the rack device (R).	
2.	Lay out the four adhesive feet in preparation.	
	<p>Check the rack device (R) you are installing; for example that the two mounting brackets are fitted at the front and that the ventilation grilles are free.</p>	
	<p>CAUTION: If you install a rack device (R) with components inserted. The locking mechanisms of components installed in the rack device (R) (for example the handles of media modules or the clips on the SFP) must be closed. See also installation of modular devices:</p> <ul style="list-style-type: none"> - Installing media modules in a slot - Installing an SFP in an SFP media module. 	
4.	Turn the rack device (R) over and fit the four adhesive feet on the base.	
5.	Fit the connectors for the 24 V power supply.	
6.	Fit the remaining connectors, for example the signaling contact.	

Removal

Removing from the rack	
1.	Turn off the power supply for the SCALANCE XR-300M.
2.	Disconnect all cables for data traffic and the connectors for the power supply and the grounding cable.
3.	<p>Undo the screws on the mounting bracket and remove the rack device (R) from the 19" cabinet.</p> <p>If necessary, release the locking mechanisms of components inserted in the rack device (R) (for example handles on the media module or clips on the SFP) to be able to remove the media modules (MM900) or the transceiver (SFP).</p>

5.2.5 19" rack mounting - X-300EEC product group

The X-300EEC can be installed in a rack singly or as pairs.

- Mounting singly:

To do this, an X-300EEC device is secured to a plate and screwed into the 19" rack.

- Mounting as pairs:

Here, two X-300EEC devices are fastened together with plates before installation in the rack:

- 1 plate as middle section (6 screws)
- 2 plates on the outside (3 screws each)

You will find dimension drawings of the plates in section X-300EEC dimension drawings (Page 294).

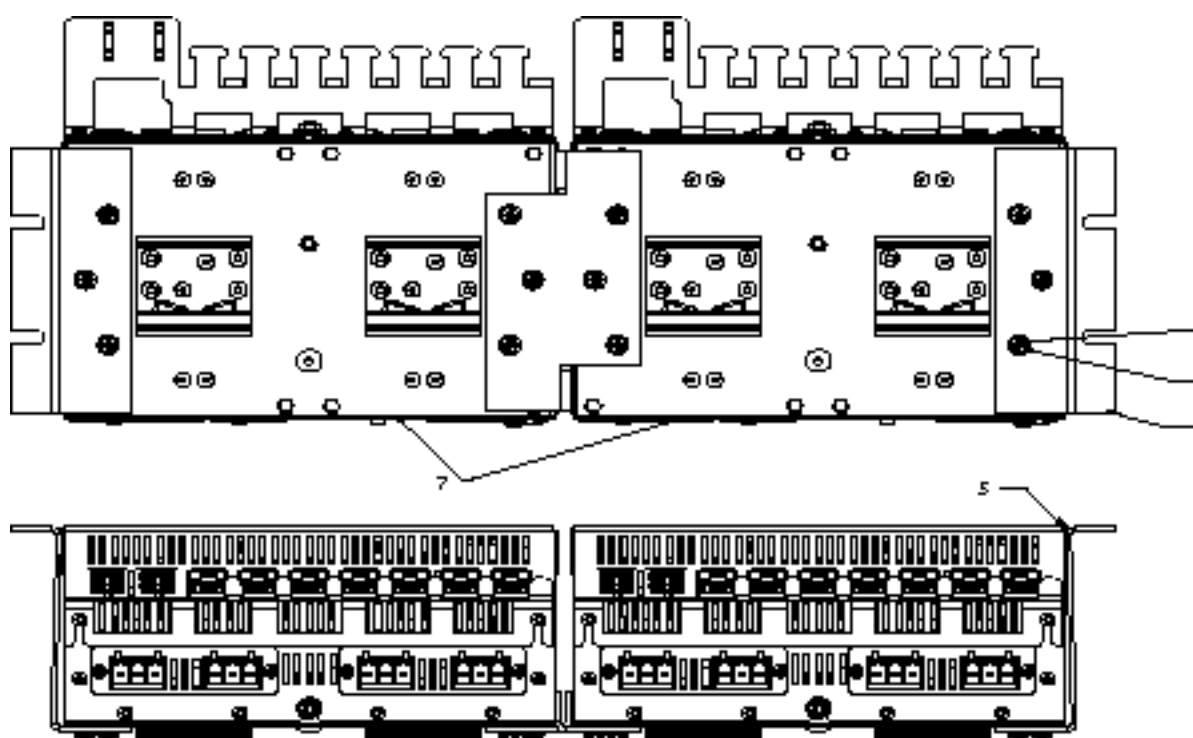



Image 5-4 Rack mounting of two IE-Switches X-300EEC fastened together
 Figure at top: Rear of the switches
 Figure at bottom: View from below

Table 5- 3 Legend for rack mounting of two IE-Switches X-300EEC fastened together

No.	Name
1	Plate for side
2	Spring washer
3	Hexagonal nut

No.	Name
5	Side section (the side panel should be under slight tension)
7	IE Switch X-300EEC

5.2.6 19" rack mounting - XR-300M EEC product group

 WARNING
Danger of injury by falling objects If you do not use the supplied mounting brackets for 19"rack installation, it is not possible to install the device correctly. Use only the supplied mounting brackets. There are several ways of fixing the mounting brackets depending on the mounting position required.

Grounding

 WARNING
Danger from line voltage Grounding simply via the housing is inadequate. In this case, connect the functional ground to ensure reliable operation. With devices with a supply voltage of 100 to 240 VAC / 60 to 250 VDC, you should also connect the protective earth to the grounding bolt. On the SCALANCE X-300EEC, the grounding bolt is on the bottom of the device. On the SCALANCE XR-300M EEC, the grounding bolt is on the rear of the housing between the power connectors.

19" rack mounting

19" rack mounting is possible for all rack devices identified by (XR). Refer to the technical specifications, Installation options table for each product group. The rack device is installed using two mounting brackets fitted to the front. After fitting the two mounting brackets, the rack device can then be installed in a 19" cabinet.

NOTICE

Do not cover the ventilation grilles

During installation, select a mounting position so that the ventilation grilles are always free to achieve adequate cooling. With normal orientation, the ventilation grilles are on the top, bottom and sides of the housing.

If you install more than one rack device, make sure that the permitted ambient conditions are met for all devices in the rack.

Minimum clearances

If you install the IE Switch in rack devices without forced ventilation or cooling, minimum clearances must be maintained to neighboring devices or the wall of the enclosure. By keeping to the minimum clearances, there is then an adequate stream of air for heat dissipation during operation. Keep to the following minimum clearances to neighboring devices.

Table 5- 4 Minimum clearances for installation in rack devices



Minimum clearance to devices below the switch	100 mm
Minimum clearance to devices above the switch	100 mm
Minimum clearance between two SCALANCE XR-300 EEC at an ambient temperature up to 70 °C without external ventilation	100 mm
Minimum clearance between two SCALANCE XR-300 EEC at an ambient temperature up to 60 °C without external ventilation	45 mm (1 height unit)

NOTICE



Four-point mounting

If mechanical load is high, the device should be secured at four points. You will find more detailed information in the section "Mechanical stability in operation".

Normal orientation

Normal orientation of the device	
<ul style="list-style-type: none">• The LED display is on the left of the front panel of the housing.• The Ethernet ports or the slots for the modules are also on the front of the housing. Slots for the modules are fitted with dummy covers.• The C-PLUG is on the right behind a protective panel secured with screws. (For more detailed information, refer to the section on the C-PLUG in the X-300 operating instructions.)• The ventilation grilles are on the top, bottom and sides of the housing.	 <p>SCALANCE XR324-4M EEC</p>
<ul style="list-style-type: none">• On the rear of the device, you will find the diagnostics port.• The grounding bolt and the connectors for the signaling contact and power supplies are also on the rear of the device. <p>Note that there are different power supplies (see section "XR-300M EEC product group (Page 32)").</p>	 <p>SCALANCE XR324-4M EEC</p>

19" rack mounting with normal orientation

19" rack mounting	
1.	Select the required rack device and the 19" cabinet.
2.	Fix the two mounting brackets with 4 screws each to the sides of the housing. The maximum tightening torque for these screws is 0.5 Nm. 
	<p>CAUTION: If you install a rack device with components inserted. The locking mechanisms of components installed in the rack device (for example the handles of media modules or the clips on the SFP) must be closed. See also installation of modular devices:</p> <ul style="list-style-type: none"> - Installing media modules in a slot - Installing an SFP in an SFP media module.  <p>SCALANCE XR324-4M EEC</p>
3.	Insert the rack device in the 19" cabinet and hold the rack device at the required height. Make sure that nothing is obstructing air from entering the ventilation grilles. Fit the securing screws to the two mounting brackets to secure the rack device in the 19" cabinet.
4.	Connect the grounding bolts. On the SCALANCE X-300EEC, the PE connector is on the bottom of the device. On the SCALANCE XR-300M EEC, the PE connector is on the rear of the device between the power connectors.
5.	Fit the connectors for the power supply. Note that the SCALANCE X-300 is available for different power supplies (100 to 240 VAC and 24 VDC variants).
6.	Fit the remaining connectors, for example the signaling contact.

Removal

Removing from the rack	
1.	Turn off the power supply for the SCALANCE XR-300M.
2.	Disconnect all cables for data traffic and the connectors for the power supply and the grounding cable.
3.	Undo the screws on the mounting bracket and remove the rack device from the 19" cabinet. If necessary, release the locking mechanisms of components inserted in the rack device (for example handles on the media module or clips on the SFP) to be able to remove the media modules (MM900) or the transceiver (SFP).

5.3 Inserting media modules and SFP transceivers

5.3.1 Installation and removal of media modules

Connecting media modules and SFP transceivers

 WARNING
Install and remove media modules only when the power is off Media modules may only be inserted in or removed from a SCALANCE device when the power supply to the device has been turned off. Use only approved media modules Use only "MM900" media modules in the module slots of SCALANCE devices.

 CAUTION
Remember the orientation of media modules. On modular devices, there are always two module slots arranged opposite each other. Remember the correct orientation when installing MM900 media modules. Example: <ul style="list-style-type: none">• The first MM900 media module is installed in slot 3.• The second MM900 media module installed in slot 4 must be turned through 180 degrees. On modular devices for rack mounting, pairs of module slots are located one above the other in which modules can be inserted in a specific order: Example of a rack device: <ul style="list-style-type: none">• The first MM900 media module is installed in slot 1.• The second MM900 media module installed in slot 7 must be turned through 180 degrees. Other modules are then inserted in slots 2 and 8 or 3 and 9 etc. The permitted operating temperature is decided by the fully equipped device (switch + media module + SFP transceiver). With modular devices, it is not only the switch that decides the permitted operating temperature of the overall device but also the temperature ranges of the MM900 media modules and the SFP transceivers. You will find details in the technical specifications of the relevant components. The following aspects can restrict the maximum permitted operating temperature: <ul style="list-style-type: none">• The orientation of the carrier device.• The use of SFP transceivers.• The use of transceivers of the types LH, LH+ or ELH.

NOTICE**Failure of the data traffic due to contamination of optical plug-in connections**

Optical sockets and plugs are sensitive to contamination of the end face. Contamination can lead to the failure of the optical transmission network.

Close unused optical sockets and plugs as well as pluggable transceivers and slots with the supplied protective caps.

Remove the protective caps only immediately before you use the plug-in connection.

NOTICE**Use only approved SFPs**

If you use components not approved by Siemens AG, in particular SFPs, Siemens cannot accept any responsibility for the correct functioning of the "Ethernet switch system" according to the specification.

Moreover, if components are used that have not been Siemens approved, Siemens cannot vouch for their compatibility or for risk-free use of these components.

Note**Use media modules only in an approved modular device**

Use an MM900 media module only for a device equipped with suitable slots for such modules. Example: X308-2M.

The names and labeling of the media modules differ

- Example: The device is called, for example, MM992-2SFP" [6GK5 992-2AS00-8AA0], the labeling on the device is "9922AS". You will find detailed information on the labeling of the media modules in the "MM900 media modules" compact operating instructions.

Note**SFP transceivers with the SCALANCE XR324-4M EEC**

In contrast to the information in the product documentation for the SCALANCE MM900, MM992-2SFP media modules can be operated in the SCALANCE XR324-4M EEC at ambient temperatures up to a maximum of 70 °C if the following requirements are met:

- MM992-2SFP media modules as of hardware product version 02 are suitable. The hardware product version can be found on the device. You can also read out this information with the WBM or the CLI.
- Only the following SFP transceivers may be used:
 - SFP991-1
 - SFP991-1LD
 - SFP992-1
 - SFP992-1LD

Note

Slot number

With modular devices, the MM900 media modules must be given a slot number. The slot number labels are supplied with the modular devices.



Installing a media module

The media module is inserted with the handle pulled out. When the handle is inserted, the media module is locked in the device.

Note

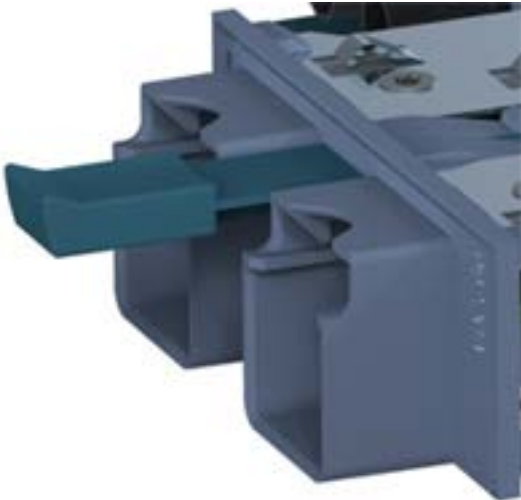
The figures in the following installation instructions show the installation of a media module in a rack device. The procedure for installation is identical for rack or compact devices.

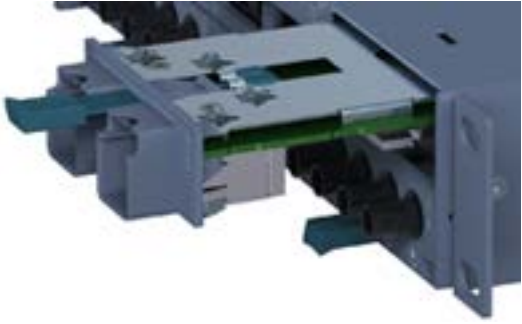
1.	Select the required slot on the device (for example, X308-2M). Remove the dummy cover.	
2.	Pull out the handle on the selected media module.	

3.	Place the media module in the guide rails of the device slot. The media module is correctly installed when it clips easily into the device.	
4.	Push the handle back into the media module. This locks the media module in the device.	
5.	Insert the connectors.	

Removing a media module

CAUTION

Risk of burns due to the high temperature of the module housing

Before removing an MM900 media module, turn the switch off and allow the device to cool down first.

1. Remove all connectors from the media module.
2. Pull out the handle of the media module and remove the media module from the device slot.
3. Secure the dummy cover.

5.3.2 SFP installation in SFP media module



NOTICE
Use only approved SFPs
If you use SFPs that are not approved by Siemens AG, there is no guarantee that the device will function according to the specification.
If you use unapproved SFPs, this can lead to the following problems:
<ul style="list-style-type: none">• Damage to the device• Loss of the approvals• Violation of the EMC regulations
Use only approved SFPs.

You can insert or remove the SFP during ongoing operation.

Inserting an SFP

Note
Only the media module MM992-2SFP may be fitted with approved SFPs. The SFP media module can be fitted with up to two SFPs.

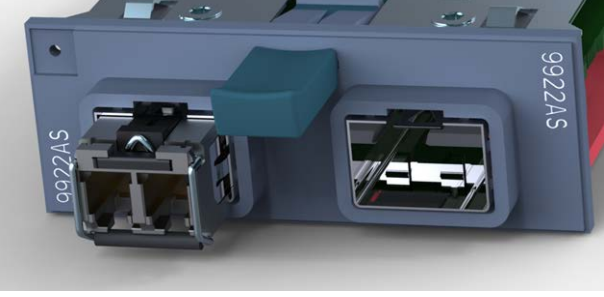
Device: Media module	Variant	[Order number] Labeling on the device	Figure
MM992-2SFP (SFP media module)	2 x 100/1000 Mbps	[6GK5 992-2AS00-8AA0] 9922AS	

1.	Select the required SFP media module in the slot of the device. (Example: X-308-2M, slot 2)	
2.	<p>Insert the SFP with the clip closed in the SFP media module.</p> <p>Notice: Closing the clip after insertion does not lock the device in the rack.</p>	
3.	The SFP can be heard to lock in place and is therefore firmly secured.	
4.	<p>Plug the connecting cable into the SFP.</p> <p>The connecting cable can be heard to lock in place and is then firmly secured.</p>	

Removing an SFP

1. Remove the cable connected to the SFP.
2. Open the clip on the SFP and remove the SFP from the SFP media module.

Notice: It must be possible to remove the SFP easy without using force.
3. Fit a blind plug to the SFP.

 WARNING
Before connecting up and commissioning the device, read the information in the section Safety instructions (Page 15)

NOTICE
Failure of the data traffic due to contamination of optical plug-in connections
Optical sockets and plugs are sensitive to contamination of the end face. Contamination can lead to the failure of the optical transmission network.
Close unused optical sockets and plugs as well as pluggable transceivers and slots with the supplied protective caps.
Remove the protective caps only immediately before you use the plug-in connection.

Note**Commissioning devices with redundancy mechanisms**

If you use redundancy mechanisms ("HRP" media redundancy or "MRP" and/or redundant coupling of rings over standby coupling), open the redundant path before you insert a new or replacement device in an operational network. A bad configuration or attachment of the Ethernet cables to incorrectly configured ports causes overload in the network and a breakdown in communication.

A device may only be inserted in a network and connected in the following situations:

- **HRP/MRP:**
The ring ports of the device being inserted in the ring were configured as ring ports. The required redundancy mode must also be enabled (see "Configuration Manual SCALANCE X-300 / X-400", section "X-300 Ring Configuration"). If the device is intended to operate as the redundancy manager, "Redundancy manager enabled" must also be set.
 - **Standby coupling:**
"Standby connection" must be "enabled" and the "Standby connection name" must match the name of the partner device. You will also need to configure the port with "Enable Standby Port Monitoring" (see "Configuration Manual SCALANCE X-300 / X-400", section "X-300/X-400 Standby Mask").
-

6.1 Wiring rules (SCALANCE X-300, X-300M, X-300M PoE)

When wiring use cables with the following AWG categories or cross sections.

Wiring rules for ...		Screw-type terminals/Spring-loaded terminals
connectable cable cross sections for flexible cables ...	without wire end ferrule	0.2 - 2.5 mm ² AWG: 24 - 13
	with wire end ferrule with plastic ferrule**	0.25 - 2.5 mm ² AWG: 24 - 13
	with wire end ferrule without plastic ferrule**	0.25 - 2.5 mm ² AWG: 24 - 13
	with TWIN wire end ferrule**	0.5 - 1 mm ² AWG: 20 - 17
Stripped length of the cable		8 - 10 mm
Wire end ferrule according to DIN 46228 with plastic ferrule**		8 - 10 mm

* AWG: American Wire Gauge

** See note "Wire end ferrules"

Note

Wire end ferrules

Use crimp shapes with smooth surfaces, such as provided by square and trapeze shaped crimp cross sections.

Crimp shapes with wave-shaped profile are unsuitable.

6.2 Connecting the switch

Procedure for connecting the device

Follow the steps below to connect the device:

1. Turn off the power supply.
2. Connect the grounding of the switch according to the following description.
3. Connect the signaling contact of the switch according to the following description.
4. Connect the power supply of the switch according to the following description.
5. Connect the network nodes / subnets to the switch.
6. Turn on the power supply for the switch.

6.3 Connecting media modules/SFPs

Power supply of the MM900 media modules

The MM900 media modules are supplied with power by the switch.

Power supply of the SFP transceivers

The SFP transceivers are supplied with power via the SFP media module.

6.4 Connecting the grounding

6.4.1 Connecting the functional ground (XR-300M EEC)

Installation on a DIN rail

The device is grounded over the DIN rail.

S7 standard rail

The device is grounded over its rear panel and the neck of the screw.

Wall mounting

The device is grounded by the securing screw in the unpainted hole.

Please note that IE Switches X-300 must be grounded over one securing screw with minimum resistance.

If an IE Switch X-300 is mounted on a non-conducting base, a grounding cable must be installed. The grounding cable is not supplied with the device. Connect the paint-free surface of the IE Switch X-300 to the nearest grounding point using the grounding cable.

19" rack mounting

- 24 VDC variant:
Grounding is via the mounting bracket on the device or alternatively/additionally via the screw-on bolts on the rear of the device.
- 100 to 240 VAC variant:
Grounding is via the mounting bracket on the device or alternatively/additionally via the screw-on bolts on the rear of the device.

6.4.2 Grounding of the X-300EEC

Functional ground

With the devices X-300EEC and XR-300M EEC with a 100 to 240 VAC / 60 to 250 VDC power supply, functional ground must be connected to the grounding bolts or the power supply terminal of every power supply unit. With the devices X-300EEC and XR-300M EEC with 24 to 48 VDC, functional ground must be connected to the grounding bolts or the mounting brackets (XR-300M EEC). On the X-300EEC, the functional ground is on the bottom of the device, on the XR-300M-EEC on the side.

To wire up the functional ground, use a copper cable of category 18-8 AWG or cable with a cross-section of 0.75 to 6 mm².

Protective ground

When the device is operated with multirange power supply unit 100 to 240 VAC / 60 to 250 VDC, the protective ground is connected in addition to the functional ground.

CAUTION

Danger from line voltage

Grounding simply via the housing is inadequate.

In this case, connect the functional ground to ensure reliable operation.

With devices with a supply voltage of 100 to 240 VAC / 60 to 250 VDC, you should also connect the protective earth to the grounding bolt.

On the SCALANCE X-300EEC, the grounding bolt is on the bottom of the device.

On the SCALANCE XR-300M EEC, the grounding bolt is on the rear of the housing between the power connectors.

To wire up the protective ground, use a copper cable of category 14-8 AWG or cable with a cross-section of 1.5 to 6 mm².



Grounding bolts on the underside of the housing of the X-300EEC or on the rear of the XR-300M-EEC

6.5 Power supply

6.5.1 24 VDC power supply

6.5.1.1 24 VDC safety extra low voltage

24 V safety extra-low voltage (SELV)

 **WARNING**

Operation only with safety-extra low voltage

- The IE Switch X-300 is designed for operation with safety extra-low voltage (SELV). This means that only safety extra-low voltages (SELV) complying with IEC950/EN60950/ VDE0805 can be connected to the power supply terminals.
- The power supply unit for the IE Switch X-300 power supply must meet NEC Class 2, as described by the National Electrical Code(r) (ANSI/NFPA 70).
- The power of all connected power supply units must total the equivalent of a power source with limited power (LPS limited power source).
- If the device is connected to a redundant power supply (two separate power supplies), both power supplies must meet these requirements.
- The signaling contact can be subjected to a maximum load of 100 mA (safety extra-low voltage (SELV), 24 VDC).
- Never operate the device with AC voltage or DC voltage higher than 32 V DC.

 **CAUTION**

Overvoltage protection for the power supply cables

If IE Switches X-300 are supplied over long 24 V power supply lines or networks, measures are necessary to prevent interference by strong electromagnetic pulses on the supply lines. These can result, for example, due to lightning or switching of large inductive loads.

One of the tests used to attest the immunity of devices of the IE Switches X-300 to electromagnetic interference was the "surge immunity test" according to EN61000-4-5. This test requires overvoltage protection for the power supply lines (does not apply to the X-300EEC). A suitable device is, for example, the Dehn Blitzductor BVT AVD 24 article no. 918 422 or a comparable protective element.

Manufacturer: DEHN+SÖHNE GmbH+Co.KG, Hans Dehn Str. 1, Postfach 1640, D - 92306 Neumarkt, Germany.

Note

Device variants

There are devices with one power supply unit or with two power supply units. Depending on the variant, the data cable outlet can be on the front or at the rear of the device.

Connecting 24 V safety extra-low voltage (SELV)

- The power supply is connected using a 4-pin plug-in terminal block.
- The power supply can be connected redundantly. Both inputs are isolated. There is no distribution of load. When a redundant power supply is used, the power supply unit with the higher output voltage supplies the IE Switch X-300 alone.
- The power supply is connected over a high resistance with the enclosure to allow an ungrounded set up. The two power inputs are non-floating.

Terminal block assignment (4-pin)

Table 6- 1 Pinout of the 24 V safety extra-low voltage (SELV)

Pin number	Assignment	Labeling (example)
Pin 1	L1+ 24 V DC	
Pin 2	M1	
Pin 3	M2	
Pin 4	L2+ 24 V DC	

6.5.1.2 24 VDC - product group X-300

Table 6- 2 24 to 48 VDC safety extra-low voltage overview

Device	Device version (power supply)	24 V safety extra-low voltage (SELV)
		can be connected redundantly
X304-2FE	1 x 24 VDC	•
X306-1LD FE	1 x 24 VDC	•
X307-3	1 x 24 VDC	•
X307-3LD	1 x 24 VDC	•
X308-2	1 x 24 VDC	•
X308-2LD	1 x 24 VDC	•
X308-2LH	1 x 24 VDC	•
X308-2LH+	1 x 24 VDC	•
X310	1 x 24 VDC	•
X310FE	1 x 24 VDC	•

Device	Device version (power supply)	24 V safety extra-low voltage (SELV)
		can be connected redundantly
X320-1 FE	1 x 24 VDC	•
X320-3LD FE	1 x 24 VDC	•

6.5.1.3 12 / 24 VDC - product group X-300M

Table 6- 3 24 to 48 VDC safety extra-low voltage overview

Device	Device version (power supply)	24 V safety extra-low voltage (SELV)
		can be connected redundantly
X308-2M	1 x 24 VDC	•
X308-2M TS	1 x 12 VDC	•

6.5.1.4 24 VDC - product group XR-300M

Table 6- 4 24 to 48 VDC safety extra-low voltage overview

Device	Device version (power supply)	24 V safety extra-low voltage (SELV)
		can be connected redundantly
XR324-12M	2 x 24 VDC	•

6.5.1.5 24 VDC - product group X-300EEC

Table 6- 5 24 to 48 VDC safety extra-low voltage overview

Device	Device version (power supply)	24 V safety extra-low voltage (SELV)
		can be connected redundantly
X302-7EEC	1 x 24 to 48 VDC	•
	2 x 24 to 48 VDC	•
X307-2EEC	1 x 24 to 48 VDC	•
	2 x 24 to 48 VDC	•

Table 6- 6 24 to 48 VDC safety extra-low voltage overview

Device	Device version (power supply)	24 V safety extra-low voltage (SELV)
		can be connected redundantly
XR324-4M EEC	1 x 24 to 48 VDC	•
	2 x 24 to 48 VDC	•

6.5.1.6 24 VDC - product group X-300M PoE

Table 6- 7 24 VDC safety extra-low voltage overview

Device	Device version (power supply)	24 V safety extra-low voltage (SELV)
		can be connected redundantly
X308-2M PoE	1 x 24 VDC	•

6.5.1.7 24 VDC - XR-300M PoE product group

Table 6- 8 24 VDC safety extra-low voltage overview

Device	Device version (power supply)	24 V safety extra-low voltage (SELV)
		can be connected redundantly
XR324-4M PoE	1 x 24 VDC	•
	1 x 24 VDC	•

6.5.1.8 Connector for redundant power supply

Device variants with 1 or 2 power supply units

There are devices variants with one power supply unit or with two power supply units. With device variants with two power supply units, the 2nd power supply unit is also known as the redundant power supply unit.

The connection is made using a 4-terminal plug-in terminal block to which two power supply units can be connected (connected redundantly).

If two power supply units are connected, this is known as a redundant power supply.

Connect two power supplies as described below to achieve a correlation between the pin assignment and LED display.

Connecting a redundant power supply to 1 power supply unit

Use the terminal block "X1" to connect the power supply.

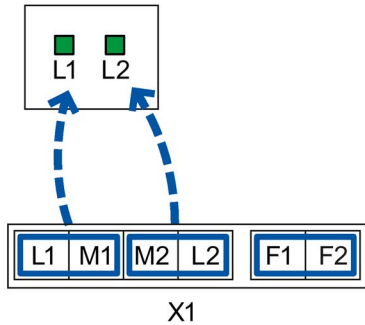

Image 6-1 Assignment of the LED display to the pins for redundant power supply with devices with one power supply unit

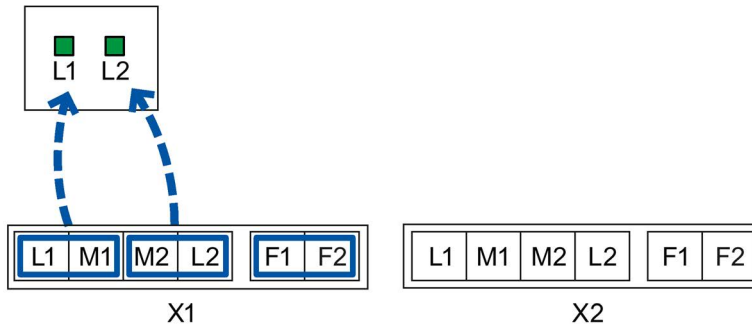

Image 6-2 Assignment of the LED display to the pins for redundant power supply with devices with two power supply units

- If the power supply fails at pins L1/M1, this is indicated by LED L1.
- If the power supply fails at pins L2/M2, this is indicated by LED L2.

Connecting a redundant power supply to 2 power supply units

To connect the power supplies, use pins L1/M1 of the left terminal block "X1" and pins L1/M1 of the right terminal block "X2". Only "L1" is monitored on each terminal block.

Since both power supply units have connectors for redundant power supply, you can connect 2 power supplies to each of the two power supply units. This should, however, only be necessary in extremely rare situations.

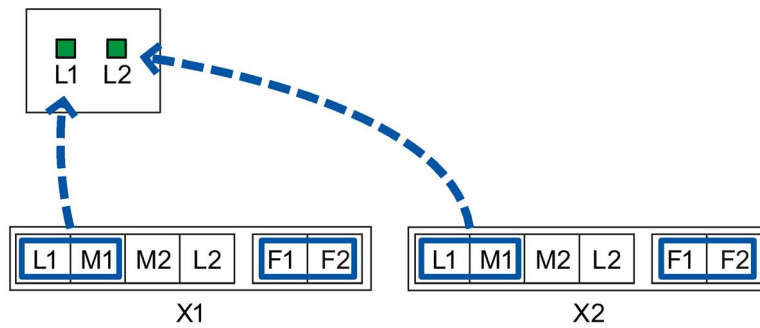

Image 6-3 Assignment of the LED display to the pins for redundant power supply with devices with two power supply units

- If the power supply fails at pins L1/M1 of terminal block "X1", this is indicated by LED L1.
- If the power supply fails at pins L1/M1 of terminal block "X2", this is indicated by LED L2.

6.5.1.9 Connecting a redundant power supply to the XR300-EEC

Device variants with 1 or 2 power supply units

There are device variants with one power supply unit or with two power supply units. With device variants with two power supply units, the 2nd power supply unit is also known as the redundant power supply unit.

The connection is made using a 4-terminal plug-in terminal block to which two power supply units can be connected (connected redundantly).

If two power supply units are connected, this is known as a redundant power supply.

Connect two power supplies as described below to achieve a correlation between the pin assignment and LED display.

Connecting a redundant power supply to 1 power supply unit

Use "PS1" to connect the power supply of the terminal block.

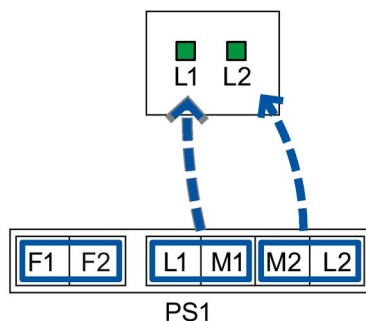

Image 6-4 Assignment of the LED display to the pins for redundant power supply with devices with one power supply unit

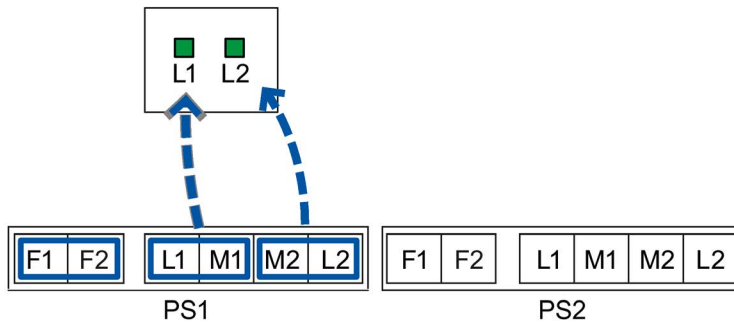

Image 6-5 Assignment of the LED display to the pins for redundant power supply with devices with two power supply units

- If the power supply fails at pins L1/M1, this is indicated by LED L1.
- If the power supply fails at pins L2/M2, this is indicated by LED L2.

Connecting a redundant power supply to 2 power supply units

To connect the power supplies, use pins L1/M1 of the left terminal block "PS1" and pins L2/M2 of the right terminal block "PS2".

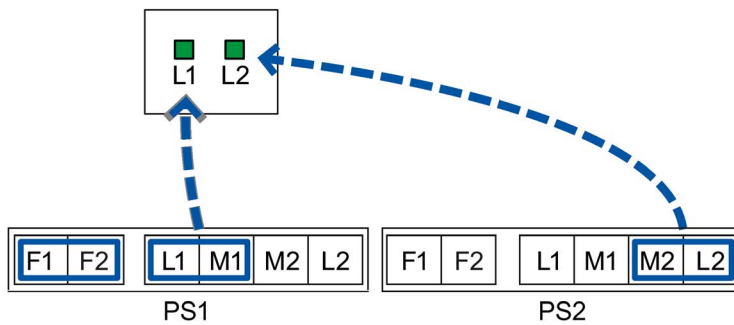

Image 6-6 Assignment of the LED display to the pins for redundant power supply with devices with two power supply units.

- If the power supply fails at pins L1/M1, this is indicated by LED L1.
- If the power supply fails at pins L2/M2, this is indicated by LED L2.

It would also be possible to use the L1/M1 pins of the right terminal block. In this case, however, identification of the terminal block involved from the LED display is not immediately obvious.

6.5.2 100 to 240 VAC power supply

<p>⚠ WARNING</p> <p>Danger from line voltage</p> <p>The supply voltage for the devices listed is 100 to 240 VAC.</p> <p>This device can only function correctly and safely if it is transported, stored, set up, and installed correctly, and operated and maintained as recommended.</p> <p>Connecting and disconnecting may only be performed by an electrical specialist.</p> <p>Connect or disconnect power supply cables only when the power is turned off!</p>
--

<p>⚠ WARNING</p> <p>Devices with a 100 to 240 VAC power supply do not have an ATEX approval.</p> <p>Devices with a 100 to 240 V AC power supply are not approved for use in hazardous areas according to EC-RL-94/9 (ATEX).</p>

<p>NOTICE</p> <p>Securing cables with dangerous voltage</p> <p>Make sure that the connector cannot be released accidentally by pulling on the connecting cable. Lay the cables in cable ducts or cable channels and secure the cables, where necessary, with cable ties.</p>
--

6.5.2.1 100 ... 240 V - product group XR-300M

Table 6- 9 100 to 240 VAC power supply overview

Device	Device version (power supply)	100 ... 240 V power supply	
		Redundant	Single
XR324-12M	1 x 100 to 240 VAC	-	•

6.5.2.2 100 to 240 VAC - product group X-300EEC

Table 6- 10 100 to 240 VAC power supply overview

Device	Device version (power supply)	100 ... 240 V power supply	
		Redundant	Single
X302-7EEC	1 x 100 to 240 VAC / 60 to 250 VDC	-	•
	2 x 100 to 240 VAC / 60 to 250 VDC	•	-

Device	Device version (power supply)	100 ... 240 V power supply	
		Redundant	Single
X307-2EEC	1 x 100 to 240 VAC / 60 to 250 VDC	-	•
	2 x 100 to 240 VAC / 60 to 250 VDC	•	-

6.5.2.3 100 to 240 VAC - XR-300M EEC product group

Table 6- 11 100 to 240 VAC power supply overview

Device	Device version (power supply)	100 ... 240 V power supply	
		Redundant	Single
XR324-4M EEC	1 x 100 to 240 VAC / 60 to 250 VDC	-	•
	2 x 100 to 240 VAC / 60 to 250 VDC	•	-

6.5.2.4 100 to 240 VAC XR-300M PoE product group

Table 6- 12 100 to 240 VAC power supply overview

Device	Device version (power supply)	100 ... 240 V power supply	
		Redundant	Single
XR324-4M PoE	1 x 100 to 240 VAC	-	•

NOTICE

Securing cables with dangerous voltage

Make sure that the connector cannot be released accidentally by pulling on the connecting cable. Lay the cables in cable ducts or cable channels and secure the cables, where necessary, with cable ties.

6.5.2.5 Fitting the connector for 100 to 240 V AC



⚠ WARNING

Danger from line voltage

If used with cables with more than two wires, correct functioning of the connector casing cannot be guaranteed because the two halves of the connector casing can come apart. If this occurs, you will also not be able to connect all the wires in the connector. Open wire ends may be dangerous due to line voltage.

Use only two-wire cables.

Procedure

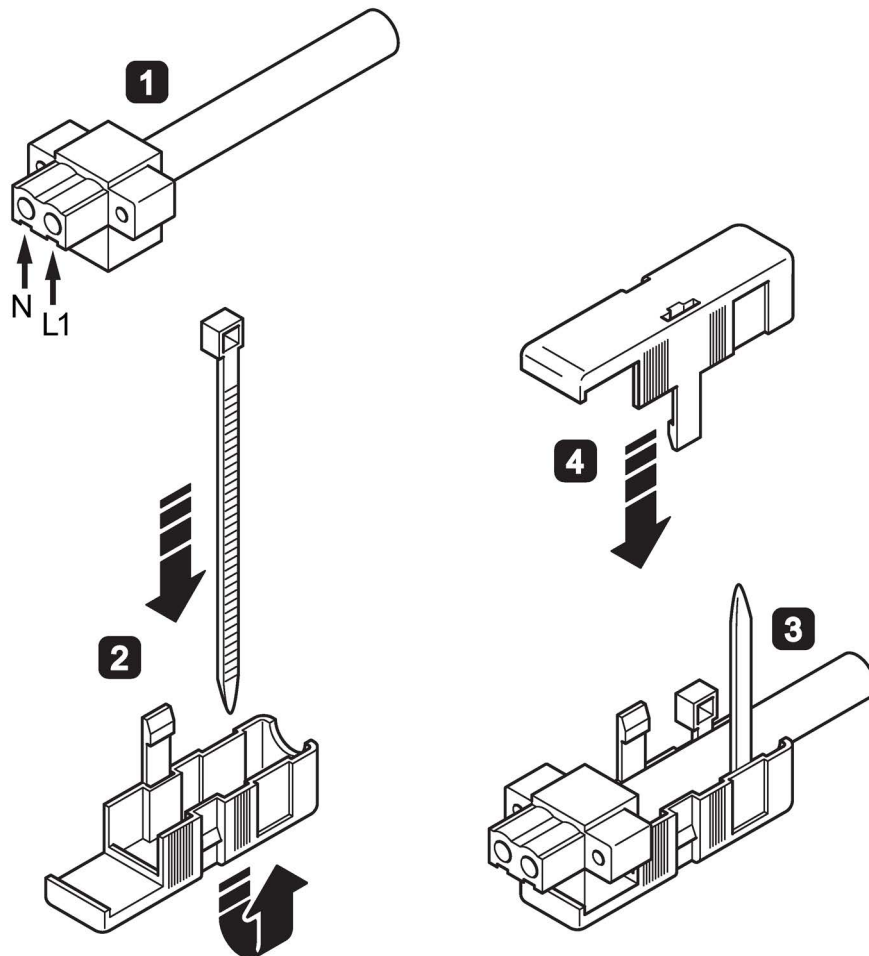

Follow the steps below to fit the connector to a two-wire cable:

1. Connect the cable to the terminal block. Strip the cable jacket only as far as necessary to be able to strip the insulation and connect up the wires.
2. Feed the supplied cable tie through the two openings in the lower part of the housing as shown in the figure.
3. Insert the terminal block with the connected cable in the lower part of the housing and tighten the cable tie. The cable must be securely held in the lower part of the housing by the cable tie. Cut off the excess cable tie.
4. Fit the upper part of the housing. The housing is correctly mounted when the two catches audibly click into place and are flush with the surface of the housing.

6.5.2.6 Connecting the 100 to 240 VAC power supply



Connecting the 100 to 240 VAC power supply via the 2-pin terminal block

There are devices with single (1 x 100 to 240 V) or redundant power supply (2 x 100 to 240 V). The cable outlet can be to the front or rear depending on the device type.

- The power supply is connected using a 2-pin plug-in terminal block.
- The two power inputs are always non-floating.

Terminal block assignment (2-pin)

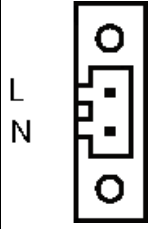
Table 6- 13 Pin assignment of the 100 to 240 VAC power supply

Pin number	Assignment	Labeling
		
Pin 1	L1 (100 to 240 VAC)	
Pin 2	N	

6.5.2.7 Connecting the power supply 100 to 240 VAC to X-300EEC / XR-300M EEC

Power supply 100 to 240 VAC / 60 to 250 VDC

The switch is available in the following versions for power supply with the multirange power supply unit 100 to 240 VAC / 60 to 250 VDC:

- With single power supply unit (1 x 100 to 240 VAC / 60 to 250 VDC)
- With redundant power supply unit (2 x 100 to 240 VAC / 60 to 250 VDC)

Each power supply unit PS1 and PS2 has a separate supply connector.

You can recognize the type of power supply from the labeling on the device and the labeling of the terminal block for the power supply of the switch.

On devices with a 100 to 240 VAC power supply, the connectors of the signaling contact and the power supply are identical. To avoid confusion, the two pins have a different coding.

Grounding

⚠ WARNING

Danger from line voltage

Grounding simply via the housing is inadequate.

In this case, connect the functional ground to ensure reliable operation.

With devices with a supply voltage of 100 to 240 VAC / 60 to 250 VDC, you should also connect the protective earth to the grounding bolt.

On the SCALANCE X-300EEC, the grounding bolt is on the bottom of the device.

On the SCALANCE XR-300M EEC, the grounding bolt is on the rear of the housing between the power connectors.

Connecting to the power supply

The connection is made via one (or two) 3-pin connector(s) on the terminal block for the power supply.

NOTICE

Damage to the device due to incorrectly wiring the terminal blocks

With devices with a supply voltage of 100 to 240 VAC and 60 to 250 VDC, the terminal blocks for the power supply and signaling contact are plugged in and screwed down in the device. Both terminal blocks have three pins but coding prevents the two terminal blocks being confused.

Make sure that the cables of the power supply and the cables for the signaling contact are connected to the correct terminal block.

Table 6- 14 Pin assignment at terminal block 100 to 240 VAC / 60 to 250 VDC for the power supply

Pin number	Assignment
Pin 1	L (100 to 240 V)
Pin 2	N
Pin 3	FE (functional earth)

To wire up the power connector, use a copper cable of category 18-8 AWG or cable with a cross-section of 0.75 to 6 mm².

DC voltage is connected at the following terminals:

- Plus to "L"
- M to "N"

Secure the firm seat of connectors and the terminal block by tightening the screws (does not apply to X-300EEC).

6.5.2.8 Connecting the 100 to 240 V AC power supply with the XR-300M PoE

Connecting to the power supply

The devices have a single power supply (1 x 100 to 240 V).

The power supply is connected using a 2-pin plug-in terminal block.

Terminal block assignment (2-pin)

Table 6- 15 Pin assignment of the 100 to 240 VAC power supply

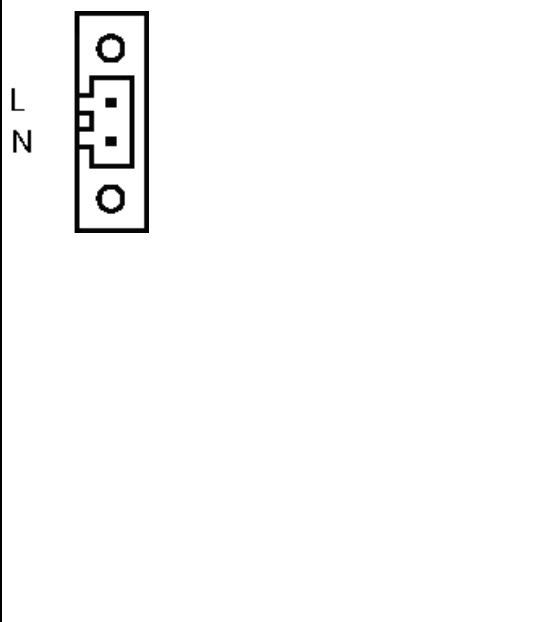
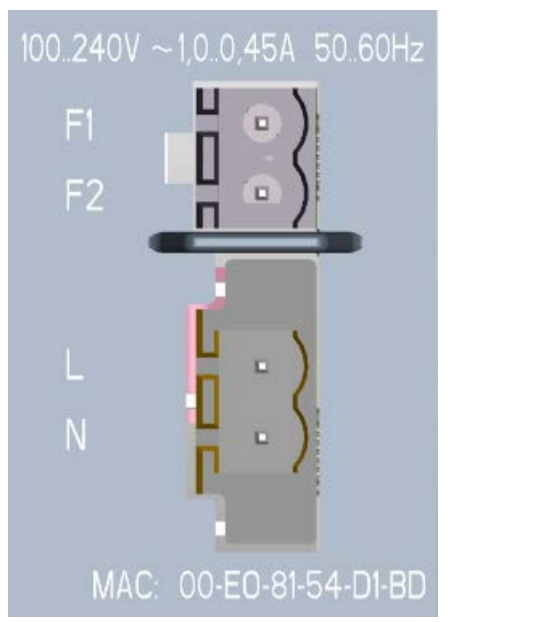
Assignment	Labeling
	

To wire up the power connector, use a copper cable of category 18-12 AWG or cable with a cross-section of 0.75 to 2.5 mm².



6.6 Signaling contact

6.6.1 24 VDC signaling contact

The signaling contact is connected to a 2-pin plug-in terminal block.

The signaling contact can be subjected to a maximum load of 100 mA (safety extra low voltage SELV 12 VDC / 24 VDC).

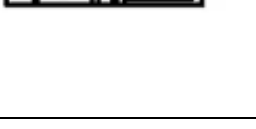
Table 6- 16 Pin assignment of the signaling contact

Pin number	Assignment (example)
<div style="display: flex; flex-direction: column; align-items: center;"> <div style="margin-bottom: 5px;">1 </div> <div>2 </div> </div>	
Pin 1	F1
Pin 2	F2

NOTICE

Laying the connecting cables of the signaling contact with the X-300EEC

To improve the EMC properties (surge protection), the two connecting cables of the signaling contact should be laid together.

6.6.2 Signaling contact 100 to 240 VAC / 60 to 250 VDC (X-300EEC)

<p>⚠ WARNING</p> <p>Danger from line voltage</p> <p>Devices with this mark have a 100 to 240 VAC power supply.</p> <p>This product can only function correctly and safely if it is transported, stored, set up, and installed correctly, and operated and maintained as recommended.</p> <p>Connecting and disconnecting may only be performed by an electrical specialist. Connect or disconnect power supply cables only when the power is turned off.</p>
--

Signaling contact 100 to 240 VAC / 60 to 250 VDC

The signaling contact is connected to a 3-pin plug-in terminal block.

Table 6- 17 Pin assignment of the 100 to 240 VAC / 60 to 250 VDC signaling contact

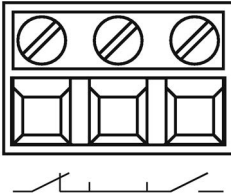
Pin number	Assignment
<p>F1 F2 F3</p> 	
F1	NC contact
F2	Root
F3	NO contact

To wire up the signaling contact, use a copper cable of category 18-8 AWG or cable with a cross-section of 0.75 to 6 mm².

<p>NOTICE</p> <p>Securing cables with dangerous voltage</p> <p>Make sure that the connector cannot be released accidentally by pulling on the connecting cable. Lay the cables in cable ducts or cable channels and secure the cables, where necessary, with cable ties.</p>
--

Configuration, displays and display elements

7.1 Assignment of slot numbers

! CAUTION

Specifying the slot number

Slots should be numbered in ascending order.

Insert a label with the slot number in the slot on the housing starting, for example, with the fixed ports and continuing with the modular ports (with MM900 media modules fitted). Include blind covers and unused slots in the numbering.

Applying the slot numbers

1. Place the required slot number in front of the module.
2. Place the tongue in the opening on the module.
3. Press the slot number into the recess on the front of the housing with your finger. The slot number breaks out of the wheel.

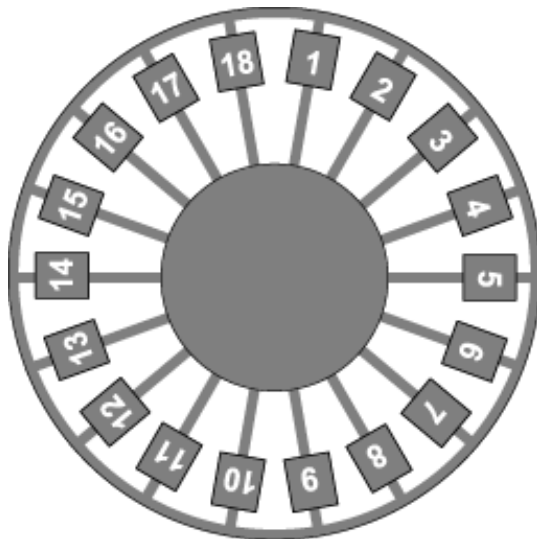

Image 7-1 Slot number plate

7.2 Show Location

Localizing an IE Switches X-300

To identify an IE Switch X-300 locally and with certainty, you can use the "show location" function on a programming device to select the node over the network and make it flash. This can be used, for example, when assigning addresses to make sure that the correct node receives the address. All port LEDs of the addressed node flash green twice a second.

With the PST Tool V3.0 or higher, you can trigger this function with "Module \ Flash".

7.3 XR-300 diagnostics port

Description

Rack devices have a diagnostics port on the rear of the housing. This port is designed for an RJ-11 plug. A suitable connecting cable with an RJ-11 plug and a 9-pin D sub female connector for connection to the serial port of the PC ships with the SCALANCE XR-300.

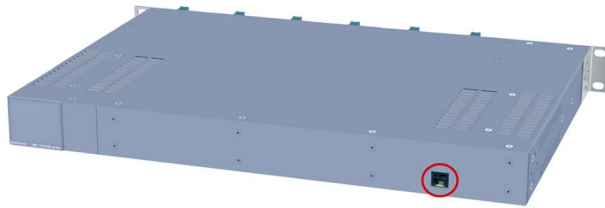

Diagnostics port on the rear of the device

Pin assignment

The following table shows the pin assignment of the RJ-11 plug and the D sub female connector:

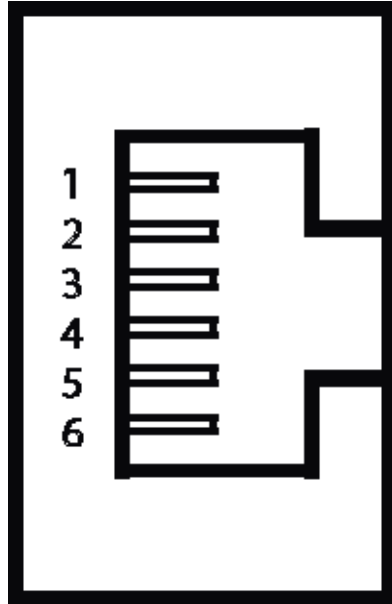

Image 7-2 RJ-11 jack (schematic)

RJ-11 plug		D-sub 9-pin, female	
Pin	Assignment	Pin	Assignment
1	n. c.	1	n. c.
2	n. c.	2	RD (Receive Data)
3	TD (Transmit Data)	3	TD (Transmit Data)
4	SG (Signal Ground)	4	n. c.
5	RD (Receive Data)	5	SG (Signal Ground)
6	n. c.	6	n. c.
		7	n. c.
		8	n. c.
		9	n. c.

7.4 The SET / SELECT button

The SET/SELECT button is located on the top of the housing of devices of the X-300 EEC series. On all other devices, this button is on the front panel of the housing beside the LED display. The SET/SELECT button has several functions that are described below.

Change the display mode

By pressing the button briefly, you change to the display mode of the LED display. For more detailed information on this topic, refer to the section "LED display".

Resetting the device to the factory defaults

If you reset, all the changes you have made will be overwritten by factory defaults. Follow the steps outlined below:

1. Turn on display mode A. Display mode A is active when the "DM" LED is not lit. If this LED is lit or flashing, you will need to press the SET/SELECT briefly (possibly several times) until the "DM" LED goes off. If the SELECT/SET button is not pressed for longer than a minute, the device also turns on display mode A.
2. Hold down the SELECT/SET button for 12 seconds. If you release the button before the 12 seconds have elapsed, the reset is canceled.

Definition of the fault mask

Using the fault mask, you specify an individual "good status" for the connected ports and the power supply. Deviations from this status are then displayed as errors/faults.

1. Turn on display mode A or D. Display mode A is active when the "DM" LED is not lit. Display mode D is active when the "DM" LED flashes yellow/orange. If a different display mode is active, you will need to press the SET/SELECT briefly (possibly several times) until the required display mode is active.
2. Hold down the SET/SELECT button for five seconds. After three seconds, the "DM" LED begins to flash. If you release the button before the five seconds have elapsed, the previous fault mask will be retained.

Enable/disable the redundancy manager

1. Turn on display mode B. Display mode B is active when the "DM" LED is lit green. If a different display mode is active, you will need to press the SET/SELECT briefly (possibly several times) until display mode B is active.
2. Hold down the SET/SELECT button for five seconds. After three seconds, the "DM" LED begins to flash. If you release the button before the five seconds have elapsed, the action is aborted.
3. The result of the action depends on the initial situation:
 - If the redundancy manager and media redundancy were disabled, media redundancy is also enabled after enabling the redundancy manager.
 - If you disable the redundancy manager, media redundancy remains enabled.

7.5 LED display

The "RM" LED for the "redundancy manager" function

The "RM" LED indicates whether or not the device is operating in the role of redundancy manager and whether or not the ring is operating error-free.

LED color	LED status	Meaning
-	off	The device is not operating in the role of "redundancy manager".
green	on	The device is operating in the role of redundancy manager. The ring is working without problems, monitoring is activated.
green	flashes	The device is operating in the role of redundancy manager. An interruption has been detected on the ring and the device has switched through.

The "SB" LED for the standby function

This LED shows the status of the standby function.

LED color	LED status	Meaning
-	off	The standby function is disabled.
green	on	The standby function is enabled. The standby section is passive.
green	flashes	The standby function is enabled. The standby section is active.

The "F" LED for the fault status

The "F" LED (fault) provides information on the error/fault status of the device. While the device is starting up, this LED has the following meaning:

LED color	LED status	Meaning during the device startup
-	off	Device startup completed successfully.
red	on	Device startup not yet completed or a fault/error has occurred.
red	flashes	Bad firmware image.

During normal operation, the "F" LED provides the following information:

LED color	LED status	Meaning during operation
-	off	No operating problems.
red	on	The device has detected an error. The signaling contact opens.

7.5 LED display

The "DM" LED for the display mode

The "DM" LED (Display Mode) indicates which of the four display modes A, B, C or D is currently active. The meaning of the L1, L2 and P1, P2, ... LEDs depends on the display mode.

LED color	LED status	Meaning
-	off	Display mode A
green	on	Display mode B
orange	on	Display mode C
yellow/orange	flashes	Display mode D

Selecting the display mode

Press the SELECT/SET button to set the required display mode. If the SELECT/SET button is not pressed for longer than a minute, the device automatically changes to display mode A.

Pressing the SELECT/SET button starting at display mode A	Status of the "DM" LED	Display mode
-	off	Display mode A (default mode)
Press once	lit green	Display mode B
Press twice	lit orange	Display mode C
Press 3 times	flashes yellow/orange	Display mode D

The "L1" and "L2" or "L" LEDs for the power supply

Whereas on other devices, the "L1" and "L2" LEDs indicate information about the power, on the SCALANCE X306-1LD FE, this is done by the "L" LED. A redundant power supply for this device can be recognized by the color of the LED.

Meaning in display mode A, B or C

LED	Color	Status	Meaning
L1 / L2	-	off	Power supply L1 / L2 lower than 17 V *)
	green	on	Power supply L1 / L2 higher than 17 V *)
L	-	off	Power supplies L1 and L2 less than 17 V or not connected.
	orange	on	Power supply L1 or L2 higher than 17 V (no redundant supply).
	green	on	Power supplies L1 and L2 higher than 17 V (redundant supply).

*) The following applies to the X-300EEC:

- For devices with power supply unit 24 to 48 VDC: Limit voltage = 17 VDC
- For devices with a multiple range power supply unit 100 to 240 VAC / 60 to 250 VDC: Limit voltage = 46.5 VDC or 80 VAC

Meaning in display mode D

LED	Color	Status	Meaning
L1 / L2	-	off	Power supply L1 / L2 is not monitored. If L1 / L2 falls below 17 V ^{*)} , the signaling contact does not respond.
	green	on	Power supply L1 / L2 is monitored. If L1 / L2 falls below 17 V ^{*)} , the signaling contact responds.
L	-	off	Power supplies L1 and L2 are not monitored. If L1 or L2 falls below 17 V, the signaling contact does not respond.
	orange	on	Power supply L1 or L2 is monitored. If L1 or L2 falls below 17 V, the signaling contact responds.
	green	on	Power supplies L1 and L2 are monitored. If L1 and L2 fall below 17 V, the signaling contact responds.
<p>^{*)}) The following applies to the X-300EEC:</p> <ul style="list-style-type: none"> • For devices with power supply unit 24 to 48 VDC: Limit voltage = 17 VDC • For devices with a multiple range power supply unit 100 to 240 VAC / 60 to 250 VDC: Limit voltage = 46.5 VDC or 80 VAC 			

Note

Devices of the X-300EEC product group

When using only one power supply unit 24 VDC and two 24 VDC power supplies, the LEDs "L1" and "L2" signal the existence of the power supply L1 and L2.

When using two 24 VDC power supply units, the LEDs "L1" and "L2" signal the existence of the primary voltage and the secondary voltage for both power supply units. If the power supply is intact, a fault occurring on a power supply unit on the secondary side can be recognized.

The P1, P2, ... LEDs for the port status

The P1, P2, ... LEDs show information on the status of their port (transmission speed, mode, port monitoring). The meaning of these LEDs depends on the display mode ("DM" LED).

Meaning in display mode A

LED color	LED status	Meaning
-	off	No valid link to the port (for example station turned off or cable not connected).
green	on	Link exists and port in normal status. In this status, the port can receive and send data.
	flashes once per second	Link exists and port in "blocking" status. In this status, the port only sends and receives management data (no user data).
	flashes 3 times per second	Link exists and port turned off by management. In this status, no data is sent or received via the port.
	flashes 4 times per second	Port exists and is in the "monitor port" status. In this status, the data traffic of another port is mirrored to this port.

7.5 LED display

LED color	LED status	Meaning
yellow	flashes / lit	Receiving data at port. With SCALANCE X-300 devices, both the receipt and the sending of data is indicated for the optical gigabit ports.

Meaning in display mode B

LED color	LED status	Meaning
-	off	Port operating at 10 Mbps.
green	on	Port operating at 100 Mbps.
orange	on	Port operating at 1000 Mbps.

If there is a problem on the connection and the type of transmission is fixed (autonegotiation off), the desired status, in other words the set transmission speed (1000 Mbps, 100 Mbps, 10 Mbps) continues to be displayed. If there is a problem on the connection and autonegotiation is active, the port LED goes off.

Meaning in display mode C

LED color	LED status	Meaning
-	off	Port operating in half duplex.
green	on	Port operating in full duplex.

Meaning in display mode D

LED color	LED status	Meaning
-	off	The port is not monitored; in other words, if a link is not established at the port, this does not trigger the signaling contact.
green	on	The port is monitored, in other words, if no connection was established at the port (for example no cable inserted), this triggers the signaling contact and an error state results.

Technical specifications

8.1 Overview of operating temperatures for SCALANCE X-300

Operating temperature depending on the media modules used

The information applies to media modules with product version 2 (PV2):

Type	Installation location	Without media module	MM992-2CUC MM992-2CU MM991-2 MM991-2LD MM991-2 (SC) MM991-2LD (SC) MM992-2 MM992-2LD	MM991-2LH+ (SC) MM992-2LH MM992-2LH+ MM992-2ELH	Media module MM992-2SFP with SFP trans- ceiver SFP991-1 SFP991-1LD SFP992-1 SFP992-1LD	Media module MM992-2SFP with SFP trans- ceiver SFP991-1LH+ SFP992-1LH SFP992-1LH+ SFP992-1ELH
X-300M	Horizontal	-40 °C to +70 °C			-40 °C to +60 °C	
	Vertical	-40 °C to +50 °C				
X-300M PoE	Horizontal	-40 °C to +60 °C		-40 °C to +50 °C	-40 °C to +60 °C	-40 °C to +50 °C
	Vertical	-40 °C to +45 °C				
XR-300M	Horizontal	Not possible (fully modular device)	-40 °C to +70 °C	Maximum 2 modules in slots 11 and 12: -40 °C to +60 °C With more than 2 modules or other slot assignment: -40 °C to +50 °C	-40 °C to +60 °C	Maximum 2 modules in slots 11 and 12: -40 °C to +60 °C With more than 2 modules or other slot assignment: -40 °C to +50 °C
	Vertical	Not possible (fully modular device)	-40 °C to +50 °C			
XR-300M PoE	Horizontal	-40 °C to +60 °C		Maximum 2 modules in slots 11 and 12: -40 °C to +60 °C With more than 2 modules or other slot assignment: -40 °C to +50 °C	-40 °C to +60 °C	Maximum 2 modules in slots 11 and 12: -40 °C to +60 °C With more than 2 modules or other slot assignment: -40 °C to +50 °C
	Vertical	-40 °C to +50 °C				

Type	Installation location	Without media module	MM992-2CUC MM992-2CU MM991-2 MM991-2LD MM991-2 (SC) MM991-2LD (SC) MM992-2 MM992-2LD	MM991-2LH+ (SC) MM992-2LH MM992-2LH+ MM992-2ELH	Media module MM992-2SFP with SFP transceiver SFP991-1 SFP991-1LD SFP992-1 SFP992-1LD	Media module MM992-2SFP with SFP transceiver SFP991-1LH+ SFP992-1LH SFP992-1LH+ SFP992-1ELH
XR-300M EEC	Horizontal	-40 °C to +70 °C		Maximum 2 modules in slots 11 and 12: -40 °C to +60 °C With more than 2 modules or other slot assignment: -40 °C to +50 °C	-40 °C to +70 °C SFP transceivers of this group can only be used in conjunction with media modules MM992-2CUC and MM992-2CU. When using other modules: -40 °C to +60 °C	Maximum 2 modules in slots 11 and 12: -40 °C to +60 °C With more than 2 modules or other slot assignment: -40 °C to +50 °C
	Vertical	-40 °C to +50 °C				

The permitted operating temperature depends on how the mounting device was installed. The installation is horizontal if the device labeling is from left to right. With a vertical installation, the device labeling is rotated through 90°.

8.2 X-300 technical specifications

Note

Validity of the technical specifications

All the technical specifications described in this section that is not assigned to a specific device variant, version or a media module, apply to all device variants/versions of the product group.

8.2.1 Construction, installation and environmental conditions

Table 8- 1 Construction

Device variant	Dimensions (W x H x D)	Weight	Degree of protection
X304-2FE, X306-1LD FE	60 × 125 × 123 mm	700 g	IP30
X307-3, X307-3LD, X308-2, X308-2LD, X308-2LH, X308-2LH+, X310, X310FE,	120 × 125 × 123 mm	1400 g	IP30
X320-1FE, X320-3LD FE	180 × 125 × 123 mm	1650 g	IP30

Table 8- 2 Installation options

Device variant	Installation options
X304-2FE, X306-1LD FE	<ul style="list-style-type: none"> • DIN rail • S7-300 standard rail • Wall
X307-3, X307-3LD, X308-2, X308-2LD, X308-2LH, X308-2LH+, X310, X310FE, X320-1FE, X320-3LD FE	<ul style="list-style-type: none"> • DIN rail ¹⁾ • S7-300 standard rail • Wall

¹⁾ Note: When used in shipbuilding, installation on a 35 mm DIN rail is not permitted. In ships, the 35 mm DIN rail does not provide adequate support.

Table 8- 3 Permitted ambient conditions

Device variant	Storage/transport temperature	Operating temperature	Max. relative humidity in operation at 25 °C	Max. ambient temperature at operating altitude
X304-2FE, X306-1LD FE, X320-1FE, X320-3LD FE	-40 °C to +70 °C	As of hardware product version 1: -40 °C to +60 °C	<= 95% (no condensation)	Max. 55 °C as of 2000 m Max. 50 °C as of 3000 m
X307-3, X308-2	-40 °C to +70 °C	For hardware product version 1: 0 °C to +60 °C As of hardware product version 2: -10 °C to +60 °C	<= 95% (no condensation)	Max. 55 °C as of 2000 m Max. 50 °C as of 3000 m
X307-3LD, X308-2LD, X308-2LH, X308-2LH+, X310, X310FE	-40 °C to +70 °C	For hardware product version 1: 0 °C to +60 °C As of hardware product version 2: -40 °C to +60 °C	<= 95% (no condensation)	Max. 55 °C as of 2000 m Max. 50 °C as of 3000 m

8.2.2 Connectors and electrical data

Table 8- 4 Connection for end devices or network components

Device variant	Electrical over twisted pair	Optical over fiber-optic cable
X304-2FE	4 x RJ-45 jacks with MDI-X assignment 10/100 Mbps (half / full duplex)	2 x SC duplex socket (MM) (100 Mbps, full duplex to 100BaseFX)
X306-1LD FE	6 x RJ-45 jacks with MDI-X assignment 10/100 Mbps (half / full duplex)	1 x SC duplex socket (SM) (100 Mbps, full duplex to 100BaseFX)
X307-3	7 x RJ-45 jacks with MDI-X assignment 10/100 Mbps (half / full duplex)	3 x SC duplex sockets (1000 Mbps, full duplex to 1000BaseSX)
X307-3LD	7 x RJ-45 jacks with MDI-X assignment 10/100 Mbps (half / full duplex)	3 x SC duplex sockets (1000 Mbps, full duplex to 1000BaseLX)
X308-2	7 x RJ-45 jacks with MDI-X assignment 10/100 Mbps (half / full duplex) 1 x RJ-45 socket with MDI-X pinning 10/100/1000 Mbps (half/ full duplex)	2 x SC duplex sockets (1000 Mbps, full duplex to 1000BaseSX)
X308-2LD	7 x RJ-45 jacks with MDI-X assignment 10/100 Mbps (half / full duplex) 1 x RJ-45 jacks with MDI-X assignment 10/100/1000 Mbps (half / full duplex)	2 x SC duplex sockets (1000 Mbps, full duplex to 1000BaseLX)

Device variant	Electrical over twisted pair	Optical over fiber-optic cable
X308-2LH	7 x RJ-45 jacks with MDI-X assignment 10/100 Mbps (half / full duplex) 1 x RJ-45 socket with MDI-X pinning 10/100/1000 Mbps (half/ full duplex)	2 x SC duplex sockets (1000 Mbps, full duplex to 1000BaseLX)
X308-2LH+	7 x RJ-45 jacks with MDI-X assignment 10/100 Mbps (half / full duplex) 1 x RJ-45 jacks with MDI-X assignment 10/100/1000 Mbps (half / full duplex)	2 x SC duplex sockets (1000 Mbps, full duplex to 1000BaseLX)
X310	7 x RJ-45 jacks with MDI-X assignment 10/100 Mbps (half / full duplex) 3 x RJ-45 jacks with MDI-X assignment 10/100/1000 Mbps (half / full duplex)	-
X310FE	10 x RJ-45 jacks with MDI-X assignment 10/100 Mbps (half / full duplex)	-
X320-1 FE	20 x RJ-45 jacks with MDI-X assignment 10/100 Mbps (half / full duplex)	1 x SC duplex socket (MM) (100 Mbps, full duplex to 100BaseFX)
X320-3LD FE	20 x RJ-45 jacks with MDI-X assignment 10/100 Mbps (half / full duplex)	1 x SC duplex socket (MM) 2 x SC duplex sockets (SM) (100 Mbps, full duplex to 100BaseFX)

Table 8- 5 Electrical data: Power supply

Rated voltage Safety extra-low voltage (SELV)	Voltage range	Permitted voltage range including total ripple
24 VDC	19.2 VDC - 28.8 VDC	18 VDC - 32 VDC

Table 8- 6 Electrical data: Power consumption

Device variant	Power loss at 24 VDC	Current consumption at rated voltage 24 VDC	Overcurrent protection at input (non- replaceable fuse)
X304-2FE	6.2 W	260 mA	3 A / 32 V
X306-1LD FE	4.8 W	200 mA	3 A / 32 V
X307-3, X307-3LD, X308-2, X308-2LD, X308-2LH, X308-2LH+, X310, X310FE, X320-1 FE	9.6 W	400 mA	3 A / 32 V
X320-3LD FE	12 W	500 mA	3 A / 32 V

Table 8- 7 Electrical data: Signaling contact

Voltage via signaling contact	24 VDC
Switching capacity (resistive load)	max. 100 mA

Table 8- 8 Plug-in terminal block for connectors of the power supply and signaling contact

Power supply	1 x 4-pin
Signaling contact	1 x 2-pin

Table 8- 9 Electrical data: Transmitter output (optical) and receiver input

Device variant	Transmitter output (optical)		Receiver input	
	min. [dBm]	max. [dBm]	Sensitivity min. [dBm]	Input power max. [dBm]
X304-2FE	-19	-14	-32	-3
X306-1LD FE	-15	-8	-34	-3
X307-3	-9.5	-4	-17	-3
X307-3LD	-9.5	-3	-21	-3
X308-2	-9.5	-4	-17	-3
X308-2LD	-9.5	-3	-21	-3
X308-2LH	-6	0	-23	-3
X308-2LH+	0	5	-23	-3
X310	-	-	-	-
X310FE	-	-	-	-
X320-1 FE	-19	-14	-32	-3
X320-3LD FE	-15 ¹⁾	-8 ¹⁾	-34 ¹⁾	-3 ¹⁾
	-19 ²⁾	-14 ²⁾	-32 ²⁾	-3 ²⁾

1) Fast Ethernet, long distance interface

2) Fast Ethernet, multimode interface

Note

Exception in the naming of X320-3LD FE

With the X320-3LD FE IE switch, the key to the name is different. The position -3LD covers a total of 3 connectors (1-2) of which only 2 connectors are LD, refer to the explanation below:

- Port 21: Multimode
- Port 22: LD (long distance, single mode)
- Port 23: LD (long distance, single mode)

Note

2 optical interface transceivers possible (X320-3LD FE)

The device is also equipped with 2 optical interface transceivers.

- 1) Fast Ethernet, long distance interface
- 2) Fast Ethernet, multimode interface

As a result, the electrical data in the technical specifications is divided into two parts: transmitter output optical and receiver input.

8.2.3 Cable lengths

Table 8- 10 Permitted cable lengths (copper cable - Fast Ethernet)

Cable type	Accessory (plug, outlet, TP cord)	Permitted cable length
IE TP torsion cable	with IE FC Outlet RJ-45 + 10 m TP cord	0 to 45 m + 10 m TP cord
	with IE FC RJ-45 Plug 180	0 to 55 m
IE FC TP Marine Cable IE FC TP Trailing Cable IE FC TP Flexible Cable	with IE FC Outlet RJ-45 + 10 m TP cord	0 to 75 m + 10 m TP cord
	with IE FC RJ-45 Plug 180	0 to 85 m
IE FC TP standard cable	with IE FC Outlet RJ-45 + 10 m TP cord	0 to 90 m + 10 m TP cord
	with IE FC RJ-45 Plug 180	0 to 100 m

Table 8- 11 Permitted cable lengths (copper cable - gigabit Ethernet)

Cable type	Accessory (plug, outlet, TP cord)	Permitted cable length
IE FC standard cable, 4×2, 24 AWG IE FC flexible cable, 4×2, 24 AWG	with IE FC RJ-45 Plug 180, 4x2	0 to 90 m
IE FC standard cable, 4×2, 22 AWG	with IE FC Outlet RJ-45 + 10 m TP cord	0 to 60 m + 10 m TP cord
IE FC flexible cable, 4×2, 22 AWG	with IE FC Outlet RJ-45 + 10 m TP cord	0 to 90 m + 10 m TP cord

Table 8- 12 Permitted cable lengths (fiber-optic cable - Fast Ethernet)

Device variant	Fiber-optic cable type	Permitted cable length	Attenuation
X304-2FE, X320-1 FE	50/125 µm multimode fiber	0 to 5 km	≤1 dB/km at 1310 nm; 1200 MHz×km; maximum insertion loss 0.5 dB; 9 dB max. permitted FO cable attenuation at 3 dB link power margin
	62.5/125 µm multimode fiber	0 ... 5 km	≤1 dB/km at 1310 nm; 1200 MHz×km; maximum insertion loss 0.5 dB; 9 dB max. permitted FO cable attenuation at 3 dB link power margin
X306-1LD FE	9/125 µm single mode fiber	0 to 26 km	≤0.5 dB/km at 1310 nm; maximum insertion loss 0.5 dB; 14 dB max. permitted FO cable attenuation at 2 dB link power margin
X310FE	-	-	-
X320-3LD FE	50/125 µm multimode fiber	0 to 5 km	≤1 dB/km at 1310 nm; 1200 MHz×km; maximum insertion loss 0.5 dB; 9 dB max. permitted FO cable attenuation at 3 dB link power margin
	9/125 µm single mode fiber	0 to 26 km	≤0.5 dB/km at 1310 nm; maximum insertion loss 0.5 dB; 14 dB max. permitted FO cable attenuation at 2 dB link power margin

Table 8- 13 Permitted cable lengths (fiber-optic cable - gigabit)

Device variant	Fiber-optic cable type	Permitted cable length	Attenuation
X307-3, X308-2	62.5/125 µm multimode fiber	0 to 350 m	≤3.1 dB/km at 850 nm; 1200 MHz×km; maximum insertion loss 0.5 dB; 4.5 dB max. permitted FO cable attenuation at 3 dB link power margin
	50/125 µm multimode fiber	0 to 750 m	≤2.5 dB/km at 850 nm; 1200 MHz×km; maximum insertion loss 0.5 dB; 4.5 dB max. permitted FO cable attenuation at 3 dB link power margin
X307-3LD X308-2LD	9/125 µm single mode fiber	0 to 10 km	≤0.5 dB/km at 1310 nm; maximum insertion loss 0.5 dB; 6 dB max. permitted FO cable attenuation at 3 dB link power margin
X308-2LH	9/125 µm single mode fiber	... 40 km	≤0.4 dB/km at 1550 nm; maximum insertion loss 0.5 dB; 18 dB max. permitted FO cable attenuation at 2 dB link power margin; minimum cable attenuation 3 dB
X308-2LH+	9/125 µm single mode fiber	... 70 km	≤0.28 dB/km at 1550 nm; maximum insertion loss 0.5 dB; 21 dB max. permitted FO cable attenuation at 2 dB link power margin; minimum cable attenuation 8 dB
X310	-	-	-

8.2.4 Other properties

Table 8- 14 Switching properties

Max. number of learnable addresses	8000
Aging time	30 sec
Switching technique	Store and forward
Latency	5 μ s

Table 8- 15 Reconfiguration times for redundancy mechanisms

Redundancy mechanism	Reconfiguration times
HRP	300 ms
Standby link	300 ms
MRP	200 ms

Table 8- 16 Mean time between failure (MTBF)

Device variant	MTBF ¹⁾
X304-2FE	55 years
X306-1LD FE	65 years
X307-3	40 years
X308-2	42 years
X307-3LD , X308-2LD, X308-2LH, X308-2LH+,	38 years
X310, X310FE	45 years
X320-1 FE	35 years
X320-3LD FE	30 years

¹⁾ These values apply at 40 °C.

Note

The IE Switches X-300 support "full wire speed switching" complying with IEEE 802.3 on all ports. The number of packets therefore depends on the packet length.

Table 8- 17 Full wire speed switching

Number of frames per second		At a frame length of
At 100 Mbps	At 1000 Mbps	
148810	1488095	64 bytes
84459	844595	128 bytes
45290	452899	256 bytes
23496	234962	512 bytes
11973	119732	1024 bytes
9615	96154	1280 bytes
8127	81274	1518 bytes

Note

The following applies to IE Switches X-300:

The number of IE Switches X-300 connected in a line influences the frame delay time. When a frame passes through the switch, this is delayed by the Store&Forward function of the IE Switch X-300 by the following values:

- at 64 bytes frame length: Delay of approx. 10 microseconds (at 100 Mbps)
- at 1500 bytes frame length: Delay of approx. 130 microseconds (at 100 Mbps)

This means, the more IE Switches X-300 a frame runs through, the higher the frame delay.

8.3 X-300M technical specifications

Note

Validity of the technical specifications

All the technical specifications described in this section that is not assigned to a specific device variant, version or a media module, apply to all device variants/versions of the product group.

8.3.1 Construction, installation and environmental conditions

Table 8- 18 Construction

Dimensions (W x H x D)	120 × 125 × 124 mm
Weight	1400 g
Degree of protection	IP20

Table 8- 19 Installation options

Installation options	<ul style="list-style-type: none"> • DIN rail ¹⁾ • S7-300 standard rail • Wall
----------------------	--

¹⁾ Note: When used in shipbuilding, installation on a 35 mm DIN rail is not permitted. In ships, the 35 mm DIN rail does not provide adequate support.

Table 8- 20 Permitted ambient conditions

Storage/transport temperature	-40 °C to +85 °C
Max. relative humidity in operation at 25 °C	<= 95% (no condensation)
Max. ambient temperature at operating altitude	2000 m or above: -5 °C of the max. operating temperature ¹⁾ 3000 m or above: -10 °C of the max. operating temperature ¹⁾

¹⁾ See table: "Operating temperature depending on the media modules used"

Table 8- 21 Operating temperature depending on the media modules used

Media module	Installation direction	Operating temperature ¹⁾	
Without media module	Horizontal	-40 °C to +70 °C	
	Vertical	-40 °C to +50 °C	
MM992-2CUC MM992-2CUC (C) MM992-2CU MM992-2M12 (C) MM992-2VD MM991-2 MM991-2FM MM991-2LD MM991-2 (SC) MM991-2LD (SC) MM992-2 MM992-2 (C) MM992-2LD	Horizontal	-40 °C to +70 °C	
	Vertical	-40 °C to +50 °C	
	MM991-2LH+ (SC) MM992-2LH MM992-2LH+ MM992-2ELH	Horizontal	-40 °C to +70 °C
		Vertical	-40 °C to +50 °C
		Horizontal	-40 °C to +60 °C

Media module	Installation direction	Operating temperature ¹⁾
with pluggable transceiver SFP991-1 SFP991-1LD SFP992-1 SFP992-1LD	Vertical	-40 °C to +50 °C
Media module MM992-2SFP with pluggable transceiver SFP991-1LH+ SFP992-1LH+ SFP992-1LH+ SFP992-1ELH SFP991- 1ELH200	Horizontal	-40 °C to +60 °C
	Vertical	-40 °C to +50 °C
MM991-2P		- 25 °C to + 40 °C

¹⁾ The permitted operating temperature depends on how the mounting device was installed. The installation is horizontal if the device labeling is from left to right. With a vertical installation, the device labeling is rotated through 90°.

8.3.2 Connectors and electrical data

Table 8- 22 Connection for end devices or network components

Max. number	8 ports
Electrical (via twisted-pair)	4 x RJ-45 jacks with MDI-X assignment 10/100/1000 Mbps (half / full duplex)
Media module slots	4 x modular (2 ports per slot)
Transmitter output (optical) and receiver input	The values correspond to those of the permitted MM900 media modules and SFP transceivers.

Table 8- 23 Electrical data: Power supply

Device version (power supply)	Redundant power supply unit	Redundant power supply possible	Power supply	
12 VDC	No	Yes	12 VDC (10.6 to 32 VDC)	
24 VDC	No	Yes	Rated voltage	24 VDC
			Voltage range	19.2 VDC - 28.8 VDC
			Permitted voltage range incl. total ripple	18 VDC - 32 VDC

Table 8- 24 Electrical data: Current consumption and power loss

Device version (power supply)	Current consumption	Effective power loss
12 VDC	1.4 A	16.6 W
24 VDC	0.7 A	16.6 W

Table 8- 25 Electrical data: Overcurrent protection

Device version (power supply)	Overcurrent protection of the power supply Non-replaceable fuse
12 VDC	3 A / 32 V
24 VDC	3 A / 32 V

Table 8- 26 Electrical data: Signaling contact

Device version (power supply)	Voltage via signaling contact	Switching capacity (resistive load)
12 VDC	12 VDC / 24 VDC	Max. 100 mA
24 VDC	24 VDC	Max. 100 mA

Table 8- 27 Plug-in terminal block for connectors of the power supply and signaling contact

Device version (power supply)	Power supply	Signaling contact
12 VDC	1 x 4-pin	1 x 2-pin
24 VDC	1 x 4-pin	1 x 2-pin

8.3.3 Cable lengths

Table 8- 28 Permitted cable lengths (copper cable - Fast Ethernet)

Cable type	Accessory (plug, outlet, TP cord)	Permitted cable length
IE TP torsion cable	with IE FC Outlet RJ-45 + 10 m TP cord	0 to 45 m + 10 m TP cord
	with IE FC RJ-45 Plug 180	0 to 55 m

Cable type	Accessory (plug, outlet, TP cord)	Permitted cable length
IE FC TP Marine Cable IE FC TP Trailing Cable IE FC TP Flexible Cable	with IE FC Outlet RJ-45 + 10 m TP cord	0 to 75 m + 10 m TP cord
	with IE FC RJ-45 Plug 180	0 to 85 m
IE FC TP standard cable	with IE FC Outlet RJ-45 + 10 m TP cord	0 to 90 m + 10 m TP cord
	with IE FC RJ-45 Plug 180	0 to 100 m

Table 8- 29 Permitted cable lengths (copper cable - gigabit Ethernet)

Cable type	Accessory (plug, outlet, TP cord)	Permitted cable length
IE FC Standard Cable, 4 × 2, 24 AWG IE FC Flexible Cable, 4 × 2, 24 AWG	with IE FC RJ-45 Plug 180, 4 × 2	0 to 90 m
IE FC Standard Cable, 4 × 2, 22 AWG	with IE FC Outlet RJ-45 + 10 m TP cord	0 to 60 m + 10 m TP cord
IE FC Flexible Cable, 4 × 2, 22 AWG	with IE FC Outlet RJ-45 + 10 m TP cord	0 to 90 m + 10 m TP cord

Note

Permitted cable lengths (fiber-optic cable - Fast Ethernet or gigabit)

The values correspond to those of the permitted MM900 media modules and SFP transceivers.

8.3.4 Other properties

Table 8- 30 Switching properties

Max. number of learnable addresses	8000
Aging time	30 sec
Switching technique	Store and forward
Latency	5 μs

Table 8- 31 Reconfiguration times for redundancy mechanisms

Redundancy mechanism	Reconfiguration times
HRP	300 ms
Standby link	300 ms
MRP	200 ms

Mean time between failure (MTBF)

The value in the following table applies to the basic device without media modules.

MTBF	> 40 years ¹⁾
------	--------------------------

¹⁾ This value applies at 40 °C.

In the calculation of the MTBF of a modular switch, the standard parts count applies; in other words, the reciprocals of all component failure rates are added.

The reciprocal of this total is the MTBF of the entire assembly.

$$MTBF_{total} = \frac{1}{\left(\frac{1}{MTBF_{basic\ device}} + \frac{1}{MTBF_{module\ 1}} + \dots + \frac{1}{MTBF_{module\ n}} \right)}$$

Table 8- 32 Full wire speed switching

Number of frames per second		At a frame length of
At 100 Mbps	At 1000 Mbps	
148810	1488095	64 bytes
84459	844595	128 bytes
45290	452899	256 bytes
23496	234962	512 bytes
11973	119732	1024 bytes
9615	96154	1280 bytes
8127	81274	1518 bytes

Note

The IE Switches X-300 support "full wire speed switching" complying with IEEE 802.3 on all ports. The number of packets therefore depends on the packet length.

Note

The following applies to IE Switches X-300:

The number of IE Switches X-300 connected in a line influences the frame delay time. When a frame passes through the switch, this is delayed by the Store&Forward function of the IE Switch X-300 by the following values:

- at 64 bytes frame length: Delay of approx. 10 microseconds (at 100 Mbps)
- at 1500 bytes frame length: Delay of approx. 130 microseconds (at 100 Mbps)

This means, the more IE Switches X-300 a frame runs through, the higher the frame delay.

8.4 XR-300M technical specifications

Note

Validity of the technical specifications

All the technical specifications described in this section that is not assigned to a specific device variant, version or a media module, apply to all device variants/versions of the product group.

8.4.1 Construction, installation and environmental conditions

Table 8- 33 Construction

Device version (power supply)	Dimensions (W x H x D)	Weight	Degree of protection
2 x 24 VDC	483 x 44 x 305 mm	5500 g	IP20
1 x 100 to 240 VAC	483 x 44 x 305 mm	5900 g	IP20

Table 8- 34 Installation options

Device version (power supply)	Installation options
2 x 24 VDC	<ul style="list-style-type: none"> • 19" rack ¹⁾ • Desktop operation with adhesive feet
1 x 100 to 240 VAC	19" rack ¹⁾

¹⁾ Note: If mechanical load is high, the device should be secured at four points. You will find more detailed information in the section "Mechanical load in operation".

Note

No desktop operation for devices with 100 to 240 VAC power supply

Desktop operation is permitted only for the 24 VDC variants of the rack devices (R). The adhesive feet ship with the 24 VDC variants. In this case, the permitted ambient temperature is -40 °C to +50 °C.

Table 8- 35 Permitted ambient conditions

Storage/transport temperature	-40 °C to +85 °C
Max. relative humidity in operation at 25 °C	<= 95% (no condensation)
Max. ambient temperature at operating altitude	2000 m or above: -5 °C of the max. operating temperature ¹⁾ 3000 m or above: -10 °C of the max. operating temperature ¹⁾

¹⁾ See table: "Operating temperature depending on the media modules used"

Table 8- 36 Operating temperature depending on the media modules used

Media module ¹⁾	Installation direction	Operating temperature ²⁾
MM992-2CUC MM992-2CUC (C) MM992-2CU MM992-2M12 (C) MM992-2VD MM991-2 MM991-2FM MM991-2LD MM991-2 (SC) MM991-2LD (SC) MM992-2 MM992-2 (C) MM992-2LD	Horizontal	-40 °C to +70 °C
	Vertical	-40 °C to +50 °C
MM991-2LH+ (SC) MM992-2LH MM992-2LH+ MM992-2ELH	Horizontal	Maximum 2 modules in slots 11 and 12: -40 °C to +60 °C With more than 2 modules or other slot assignment: -40 °C to +50 °C
	Vertical	-40 °C to +50 °C
Media module MM992-2SFP with pluggable transceiver SFP991-1 SFP991-1LD SFP992-1 SFP992-1LD	Horizontal	-40 °C to +60 °C
	Vertical	-40 °C to +50 °C

Media module ¹⁾	Installation direction	Operating temperature ²⁾
Media module MM992-2SFP with pluggable transceiver SFP991-1LH+ SFP992-1LH SFP992-1LH+ SFP992-1ELH SFP991-1ELH200	Horizontal	Max. 2 modules in slots 11 and 12: -40 °C to +60 °C With more than 2 modules or other slot assignment: -40 °C to +50 °C
	Vertical	-40 °C to +50 °C
MM991-2P		Maximum 6 modules in slots 7 and 12: The slot above an MM991-2P may be used as follows: <ul style="list-style-type: none"> • Without media module: - 25 °C to + 50 °C • With media module MM992-2CUC or MM992-2CU: - 25 °C to + 40 °C

- 1) Only hardware product version 02 of the media modules is permitted. The hardware product version is shown on the product. You can also read out this information from the device with the WBM or the CLI.
- 2) The permitted operating temperature depends on how the mounting device was installed. The installation is horizontal if the device labeling is from left to right. With a vertical installation, the device labeling is rotated through 90°.

8.4.2 Connectors and electrical data

Table 8- 37 Connection for end devices or network components

Max. number	24 ports
Media module slots	12 x modular (2 ports per slot)
Transmitter output (optical) and receiver input	The values correspond to those of the permitted MM900 media modules and SFP transceivers.
Diagnostics port	RJ-11 jack

Table 8- 38 Electrical data: Power supply

Device version (power supply)	Redundant power supply unit	Redundant power supply possible	Power supply	
			Rated voltage	24 VDC
2 x 24 VDC	No	Yes	Voltage range	19.2 VDC - 28.8 VDC
			Permitted voltage range incl. total ripple	18.5 VDC - 30.2 VDC
			100 to 240 VAC (85 to 264 VAC)	
1 x 100 to 240 VAC	No	No		

Table 8- 39 Electrical data: Current consumption and power loss

Device version (power supply)	Current consumption	Effective power loss
2 x 24 VDC	1.8 A	44 W
1 x 100 to 240 VAC	0.8 to 0.45 A	50 W

Table 8- 40 Electrical data: Overcurrent protection

Device version (power supply)	Overcurrent protection of the power supply Non-replaceable fuse
2 x 24 VDC	5 A / 125 V
1 x 100 to 240 VAC	3.15 A / 250 V

Table 8- 41 Electrical data: Signaling contact

Voltage via signaling contact	24 VDC
Switching capacity (resistive load)	max. 100 mA

Table 8- 42 Plug-in terminal block for connectors of the power supply and signaling contact

Device version (power supply)	Power supply	Signaling contact
2 x 24 VDC	2 x 4-pin	2 x 2-pin
1 x 100 to 240 VAC	1 x 2-pin	1 x 2-pin

8.4.3 Cable lengths

Table 8- 43 Permitted cable lengths (copper cable - Fast Ethernet)

Cable type	Accessory (plug, outlet, TP cord)	Permitted cable length
IE TP torsion cable	with IE FC Outlet RJ-45 + 10 m TP cord	0 to 45 m + 10 m TP cord
	with IE FC RJ-45 Plug 180	0 to 55 m
IE FC TP Marine Cable IE FC TP Trailing Cable IE FC TP Flexible Cable	with IE FC Outlet RJ-45 + 10 m TP cord	0 to 75 m + 10 m TP cord
	with IE FC RJ-45 Plug 180	0 to 85 m
IE FC TP standard cable	with IE FC Outlet RJ-45 + 10 m TP cord	0 to 90 m + 10 m TP cord
	with IE FC RJ-45 Plug 180	0 to 100 m

Table 8- 44 Permitted cable lengths (copper cable - gigabit Ethernet)

Cable type	Accessory (plug, outlet, TP cord)	Permitted cable length
IE FC Standard Cable, 4 × 2, 24 AWG IE FC Flexible Cable, 4 × 2, 24 AWG	with IE FC RJ-45 Plug 180, 4 × 2	0 to 90 m
IE FC Standard Cable, 4 × 2, 22 AWG	with IE FC Outlet RJ-45 + 10 m TP cord	0 to 60 m + 10 m TP cord
IE FC Flexible Cable, 4 × 2, 22 AWG	with IE FC Outlet RJ-45 + 10 m TP cord	0 to 90 m + 10 m TP cord

Note

Permitted cable lengths (fiber-optic cable - Fast Ethernet or gigabit)

The values correspond to those of the permitted MM900 media modules and SFP transceivers.

8.4.4 Block architecture

Block architecture with SCALANCE XR-300 devices

The XR324-12M and XR324-4M handle the Ethernet frame traffic of the 24 ports with the aid of three switch blocks.

- The three switch blocks are connected in series (block 1 via block 2 to block 3)
- Gigabit wire speed is possible within a block (max. 8 ports per block).
- Between the blocks there is a bandwidth of 1 gigabit/s available, that must be shared by all ports for frame traffic between the blocks.

When operating solely with Fast Ethernet (100 Mbps), the XR devices support full wire speed via all blocks.

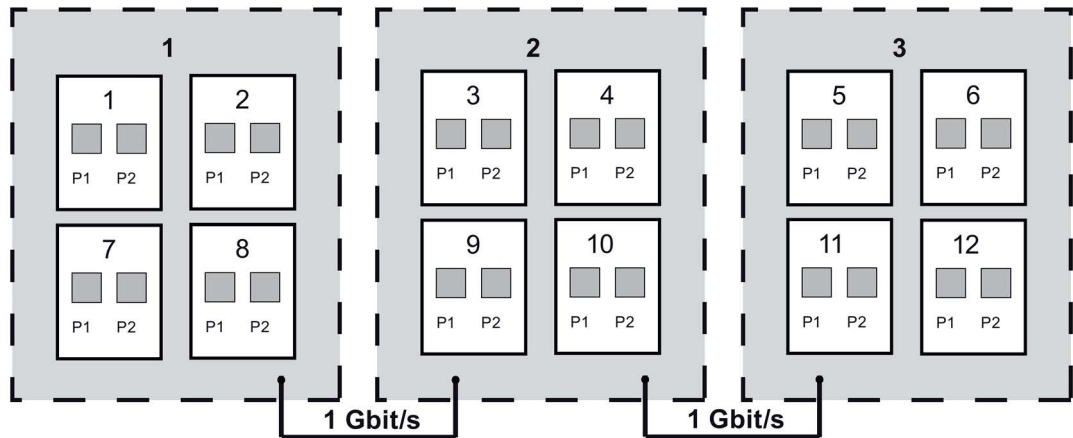

Image 8-1 Block architecture of the XR324-12M

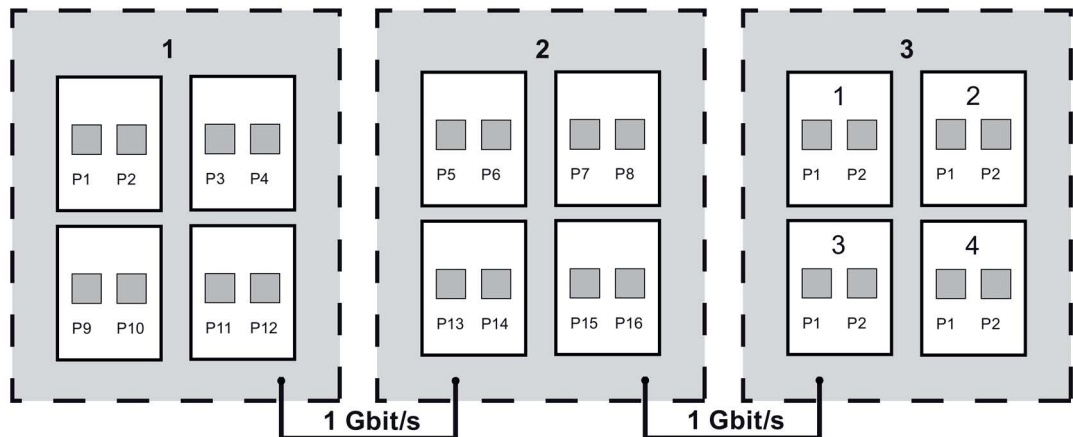

Image 8-2 Block architecture of the XR324-4M

8.4.5 Other properties

Table 8- 45 Switching properties

Max. number of learnable addresses	8000
Aging time	30 sec
Switching technique	Store and forward
Latency	5 μ s

Table 8- 46 Reconfiguration times for redundancy mechanisms

Redundancy mechanism	Reconfiguration times
HRP	300 ms
Standby link	300 ms
MRP	200 ms

Mean time between failure (MTBF)

The values in the following table apply to the basic device without media modules.

Device version (power supply)	MTBF ¹⁾
2 x 24 VDC	> 26 years
1 x 100 to 240 VAC	> 22 years

¹⁾ These values apply at 40 °C.

In the calculation of the MTBF of a modular switch, the standard parts count applies; in other words, the reciprocals of all component failure rates are added.

The reciprocal of this total is the MTBF of the entire assembly.

$$MTBF_{total} = \frac{1}{\left(\frac{1}{MTBF_{basic\ device}} + \frac{1}{MTBF_{module\ 1}} + \dots + \frac{1}{MTBF_{module\ n}} \right)}$$

Table 8- 47 Full wire speed switching

Number of frames per second		At a frame length of
At 100 Mbps	At 1000 Mbps	
148810	1488095	64 bytes
84459	844595	128 bytes
45290	452899	256 bytes
23496	234962	512 bytes
11973	119732	1024 bytes
9615	96154	1280 bytes
8127	81274	1518 bytes

Note

The following applies to IE Switches X-300:

The number of IE Switches X-300 connected in a line influences the frame delay time. When a frame passes through the switch, this is delayed by the Store&Forward function of the IE Switch X-300 by the following values:

- at 64 bytes frame length: Delay of approx. 10 microseconds (at 100 Mbps)
- at 1500 bytes frame length: Delay of approx. 130 microseconds (at 100 Mbps)

This means, the more IE Switches X-300 a frame runs through, the higher the frame delay.

8.5 Technical specifications for X-300EEC

Note

Validity of the technical specifications

All the technical specifications described in this section that is not assigned to a specific device variant, version or a media module, apply to all device variants/versions of the product group.

8.5.1 Construction, installation and environmental conditions

Table 8- 48 Construction

Device version (power supply)	Dimensions (W x H x D)	Weight	Degree of protection
1 24 VDC power supply unit	<ul style="list-style-type: none"> Without clip: 60 × 125 × 123 mm With clip: 216 × 203 × 99 mm 	1800 g	IP30
2 x 24 VDC power supply units	<ul style="list-style-type: none"> Without clip: 60 × 125 × 123 mm With clip: 216 × 203 × 99 mm 	2030 g	IP30
1 x power supply unit 100 to 240 VAC / 60 to 250 VDC	<ul style="list-style-type: none"> Without clip: 60 × 125 × 123 mm With clip: 216 × 203 × 99 mm 	1850 g	IP30
2 x power supply units 100 to 240 VAC / 60 to 250 VDC	<ul style="list-style-type: none"> Without clip: 60 × 125 × 123 mm With clip: 216 × 203 × 99 mm 	2120 g	IP30

Table 8- 49 Installation options

Installation options	<ul style="list-style-type: none"> DIN rail S7-300 standard rail ¹⁾ Wall ²⁾ 19" rack ³⁾
----------------------	--

¹⁾ Possible only with adapter (must be provided by installers).

²⁾ Wall mounting possible with suitable wall support.

³⁾ With mounting support

Table 8- 50 Permitted ambient conditions

Storage/transport temperature	Operating temperature	Max. relative humidity in operation at 25 °C	Max. ambient temperature at operating altitude
-40 °C to +70 °C	-40 °C to +70 °C ¹⁾	<= 95% (no condensation)	Max. 65 °C as of 2000 m Max. 60 °C as of 3000 m

1) The IE Switch was type tested for 16 h at +85 °C.

Table 8- 51 Mechanical stability

Strain withstood / category (standard)	Test conditions
Vibration (IEC 60068-2-6)	Frequency range 10 Hz to 150 Hz: <ul style="list-style-type: none"> • Transit frequency: 58 Hz to 60 Hz • Peak value of the displacement [mm] below the transit frequency: 0.075 • Peak value of the acceleration [g] above the transit frequency: 1 • Number of cycles per axis: 20 Frequency range 5 Hz to 150 Hz: <ul style="list-style-type: none"> • Transit frequency: 8.4 Hz • Peak value of the displacement [mm] below the transit frequency: 3.5 • Peak value of the acceleration [g] above the transit frequency: 1 • Number of cycles per axis: 10 • Octaves / min: 1 Frequency range 2 Hz to 100 Hz: <ul style="list-style-type: none"> • Frequency range: 2 Hz to 100 Hz • Transit frequency: 13.2 Hz • Peak value of the displacement [mm] below the transit frequency: 1 • Peak value of the acceleration [g] above the transit frequency: 0.7 • Number of cycles per
Vibration (IEEE1613 Class V.S.2)	<ul style="list-style-type: none"> • Velocity: <10 mm/s • Frequency: 1 to 150 Hz
Shock (IEC 60068-2-27)	<ul style="list-style-type: none"> • Acceleration: 15 g • Duration of the pulse: 11 ms • Number of shocks per direction: 3

8.5.2 Connectors and electrical data

Table 8- 52 Connection for end devices or network components

Device variant	Electrical over twisted pair	Optical over fiber-optic cable
X302-7EEC (all variants)	2 x RJ-45 jacks with MDI-X assignment 10/100/1000 Mbps (half / full duplex)	7 x LC sockets multimode (100 Mbps, full duplex)
X307-2EEC (all variants)	7 x RJ-45 jacks with MDI-X assignment <ul style="list-style-type: none"> • 5 x Fast Ethernet 10/100 Mbps (half/full duplex) • 2 x Gigabit Ethernet 10/100/1000 Mbps (half/full duplex) 	2 x LC sockets multimode (100 Mbps, full duplex)

Table 8- 53 Electrical data: Power supply

Device version (power supply)	Redundant power supply unit	Redundant power supply possible	Power supply (min./max. range)
1 power supply unit 24 to 48 VDC	No	Yes	24 to 48 VDC (19.2 to 57.6 VDC)
2 power supply units 24 to 48 VDC	Yes	Yes ¹⁾	24 to 48 VDC (19.2 to 57.6 VDC)
1 x power supply unit 100 to 240 VAC / 60 to 250 VDC	No	No	100 to 240 VAC (80 to 276 VAC) ²⁾ 60 to 250 VDC (46.25 to 300 VDC)
2 x power supply units 100 to 240 VAC / 60 to 250 VDC	Yes	Yes	100 to 240 VAC (80 to 276 VAC) ²⁾ 60 to 250 VDC (46.25 to 300 VDC)

¹⁾ With a redundant 24 VDC power supply, "L1" must be connected on both power supply units.

²⁾ AC 50/60 Hz ± 5 %

Table 8- 54 Electrical data: Current consumption and power loss

Device variant	Device version (power supply)	Current consumption	Effective power loss
X302-7ECC	24 to 48 VDC	0.8 to 0.4 A	17 W
	100 to 240 VAC / 60 to 250 VDC	0.4 to 0.3 A (AC) 0.3 to 0.1 A (DC)	18 to 19 W (AC) 17 to 18 W (DC)
X307-2ECC	24 to 48 VDC	0.5 to 0.3 A	12 W
	100 to 240 VAC / 60 to 250 VDC	0.3 to 0.2 A (AC) 0.3 to 0.1 A (DC)	12 to 13 W (AC) 12 to 13 W (DC)

Table 8- 55 Electrical data: Overcurrent protection

Device version (power supply)	Overcurrent protection of the power supply Non-replaceable fuse
1 power supply unit 24 to 48 VDC	1 x T4A / 125 V
2 power supply units 24 to 48 VDC	2 x T4A / 125 V
1 x power supply unit 100 to 240 VAC / 60 to 250 VDC	1 x T4A / 250 V (AC) 1 x T4A / 300 V (DC)
2 x power supply units 100 to 240 VAC / 60 to 250 VDC	2 x T4A / 250 V (AC) 2 x T4A / 300 V (DC)

Table 8- 56 Electrical data: Signaling contact

Device version (power supply)	Voltage via signaling contact	Switching capacity (resistive load)
24 to 48 VDC	24 VDC	max. 0.1 A
100 to 240 VAC / 60 to 250 VDC	240 VAC	max. 5 A
	60 VDC	max. 0.4 A
	125 VDC	max. 0.22 A
	250 VDC	max. 0.11 A

Table 8- 57 Plug-in terminal block for connectors of the power supply and signaling contact

Device version (power supply)	Power supply	Signaling contact
1 power supply unit 24 to 48 VDC	1 x 4-pin male connector	1 x 2-pin male connector
2 power supply units 24 to 48 VDC	2 x 4-pin male connector	2 x 2-pin connector ¹⁾
1 x power supply unit 100 to 240 VAC / 60 to 250 VDC	1 x 3-pin male connector	1 x 3-pin male connector
2 x power supply units 100 to 240 VAC / 60 to 250 VDC	2 x 3-pin male connector	2 x 3-pin connector ¹⁾

1) For redundant design connect the signaling contacts in parallel.

Table 8- 58 Electrical data: Transmitter output (optical) and receiver input

Transmitter output (optical) ¹⁾		Receiver input ¹⁾	
min. [dBm]	max. [dBm]	Sensitivity min. [dBm]	Input power max. [dBm]
-19	-14	-32	-14

1) Values for glass fiber: 62.5 to 125 µm multimode

Table 8- 59 Overvoltage category

General	Overvoltage category II
In the application range of EN 60255-27	Overvoltage category III

8.5.3 Cable lengths

Table 8- 60 Permitted cable lengths (copper cable - Fast Ethernet)

Cable type	Accessory (plug, outlet, TP cord)	Permitted cable length
IE TP torsion cable	with IE FC Outlet RJ-45 + 10 m TP cord	0 to 45 m + 10 m TP cord
	with IE FC RJ-45 Plug 180	0 to 55 m
IE FC TP Marine Cable IE FC TP Trailing Cable IE FC TP Flexible Cable	with IE FC Outlet RJ-45 + 10 m TP cord	0 to 75 m + 10 m TP cord
	with IE FC RJ-45 Plug 180	0 to 85 m
IE FC TP standard cable	with IE FC Outlet RJ-45 + 10 m TP cord	0 to 90 m + 10 m TP cord
	with IE FC RJ-45 Plug 180	0 to 100 m

Table 8- 61 Permitted cable lengths (copper cable - gigabit Ethernet)

Cable type	Accessory (plug, outlet, TP cord)	Permitted cable length
IE FC Standard Cable, 4 × 2, 24 AWG IE FC Flexible Cable, 4 × 2, 24 AWG	with IE FC RJ-45 Plug 180, 4 × 2	0 to 90 m
IE FC Standard Cable, 4 × 2, 22 AWG	with IE FC Outlet RJ-45 + 10 m TP cord	0 to 60 m + 10 m TP cord
IE FC Flexible Cable, 4 × 2, 22 AWG	with IE FC Outlet RJ-45 + 10 m TP cord	0 to 90 m + 10 m TP cord

Table 8- 62 Permitted cable lengths (fiber-optic cable - Fast Ethernet)

Fiber-optic cable type	Permitted cable length	Attenuation
62.5/125 μm 50/125 μm,	0 to 5 km	≤1 dB/km at 1310 nm; 1200 MHz×km; maximum insertion loss 0.5 dB; 9 dB max. permitted FO cable attenuation at 3 dB link power margin

8.5.4 Other properties

Table 8- 63 Switching properties

Max. number of learnable addresses	8000
Aging time	30 sec
Switching technique	Store and forward
Latency	5 μ s

Table 8- 64 Reconfiguration times for redundancy mechanisms

Redundancy mechanism	Reconfiguration times
HRP	300 ms
Standby link	300 ms
MRP	200 ms

Table 8- 65 Mean time between failure (MTBF)

Device variant	Device version	MTBF ¹⁾
X302-7EEC	1 x power supply unit 24 VDC	27 years
	2 x power supply unit 24 VDC	19 years
	1 x power supply unit 100 to 240 VAC / 60 to 250 VDC	22 years
	2 x power supply unit 100 to 240 VAC / 60 to 250 VDC	15 years
X307-2EEC	1 x power supply unit 24 VDC	29 years
	2 x 24 VDC power supply unit	20 years
	1 x power supply unit 100 to 240 VAC / 60 to 250 VDC	24 years
	2 x power supply unit 100 to 240 VAC / 60 to 250 VDC	16 years

1) These values apply at 40 °C.

Note

The IE Switches X-300 support "full wire speed switching" complying with IEEE 802.3 on all ports. The number of packets therefore depends on the packet length.

Table 8- 66 Full wire speed switching

Number of frames per second		At a frame length of
At 100 Mbps	At 1000 Mbps	
148810	1488095	64 bytes
84459	844595	128 bytes
45290	452899	256 bytes
23496	234962	512 bytes
11973	119732	1024 bytes
9615	96154	1280 bytes
8127	81274	1518 bytes

Note

The following applies to IE Switches X-300:

The number of IE Switches X-300 connected in a line influences the frame delay time. When a frame passes through the switch, this is delayed by the Store&Forward function of the IE Switch X-300 by the following values:

- at 64 bytes frame length: Delay of approx. 10 microseconds (at 100 Mbps)
- at 1500 bytes frame length: Delay of approx. 130 microseconds (at 100 Mbps)

This means, the more IE Switches X-300 a frame runs through, the higher the frame delay.

8.6 XR-300M EEC technical specifications

Note

Validity of the technical specifications

All the technical specifications described in this section that is not assigned to a specific device variant, version or a media module, apply to all device variants/versions of the product group.

8.6.1 Construction, installation and environmental conditions

Table 8- 67 Construction

Device	Device version (power supply)	Dimensions (W x H x D)	Weight	Degree of protection
XR324-4M EEC	1 x 24 to 48 VDC	483 × 44 × 305 mm	6500 g	IP20
	2 x 24 to 48 VDC	483 × 44 × 305 mm	6800 g	IP20
	1 x 100 to 240 VAC / 60 to 250 VDC	483 × 44 × 305 mm	6600 g	IP20
	2 x 100 to 240 VAC / 60 to 250 VDC	483 × 44 × 305 mm	7000 g	IP20

Table 8- 68 Installation options

Device	Installation options
XR324-4M EEC	19" rack ¹⁾

¹⁾ Note: If mechanical load is high, the device should be secured at four points. You will find more detailed information in the section "Mechanical load in operation".

Table 8- 69 Permitted ambient conditions

Storage/transport temperature	-40 °C to +85 °C
Max. relative humidity in operation at 25 °C	<= 95% (no condensation)
Max. ambient temperature at operating altitude	2000 m or above: -5 °C of the max. operating temperature ¹⁾ 3000 m or above: -10 °C of the max. operating temperature ¹⁾

¹⁾ See table: "Operating temperature depending on the media modules used"

Table 8- 70 Operating temperature depending on the media modules used

Media module ¹⁾	Installation direction	Operating temperature ²⁾
Without media module	Horizontal	-40 °C to +70 °C
	Vertical	-40 °C to +50 °C
MM992-2CUC	Horizontal	-40 °C to +70 °C

Media module ¹⁾	Installation direction	Operating temperature ²⁾
MM992-2CUC (C) MM992-2CU MM992-2M12 (C) MM992-2VD MM991-2 MM991-2FM MM991-2LD MM991-2 (SC) MM991-2LD (SC) MM992-2 MM992-2 (C) MM992-2LD	Vertical	-40 °C to +50 °C
MM991-2LH+ (SC) MM992-2LH MM992-2LH+ MM992-2ELH	Horizontal	Maximum 2 modules in slots 3 and 4: -40 °C to +60 °C With more than 2 modules or other slot assignment: -40 °C to +50 °C
	Vertical	-40 °C to +50 °C
Media module MM992-2SFP with pluggable transceiver SFP991-1 SFP991-1LD SFP992-1 SFP992-1LD	Horizontal	-40 °C to +70 °C Pluggable transceivers of this group may only be used in conjunction with media modules MM992-2CUC, MM992-2CU and MM992-2M12. When using other modules: -40 °C to +60 °C
	Vertical	-40 °C to +50 °C
Media module MM992-2SFP with pluggable transceiver SFP991-1LH+ SFP992-1LH SFP992-1LH+ SFP992-1ELH SFP991-1ELH200	Horizontal	Max. 2 modules in slots 3 and 4: -40 °C to +60 °C With more than 2 modules or other slot assignment: -40 °C to +50 °C
	Vertical	-40 °C to +55 °C
MM991-2P		Maximum 2 modules in slots 3 and 4: The slot above an MM991-2P may be used as follows: <ul style="list-style-type: none"> Without media module: - 25 °C to + 50 °C With media module MM992-2CUC or MM992-2CU: - 25 °C to + 40 °C

- ¹⁾ Only hardware product version 02 of the media modules is permitted.
The hardware product version is shown on the product. You can also read out this information from the device with the WBM or the CLI.
- ²⁾ The permitted operating temperature depends on how the mounting device was installed. The installation is horizontal if the device labeling is from left to right. With a vertical installation, the device labeling is rotated through 90°.

8.6.2 Connectors and electrical data

Table 8- 71 Connection for end devices or network components

Max. number	24 ports
Electrical	16 x RJ-45 jacks 10/100/1000 Mbps
Media module slots	4 x modular (2 ports per slot)
	12 x modular (2 ports per slot)
Transmitter output (optical) and receiver input	The values correspond to those of the permitted MM900 media modules and SFP transceivers.
Diagnostics port	RJ-11 jack

Table 8- 72 Electrical data: Power supply

Device version (power supply)	Redundant power supply unit	Redundant power supply possible	Power supply (min./max. range)
1 x 24 to 48 VDC	No	Yes	24 to 48 VDC (19.2 to 57.6 VDC)
2 x 24 to 48 VDC	Yes	Yes	24 to 48 VDC (19.2 to 57.6 VDC)
1 x 100 to 240 VAC / 60 to 250 VDC	No	No	100 to 240 VAC (80 to 276 VAC) 60 to 250 VDC (48 to 300 VDC)
2 x 100 to 240 VAC / 60 to 250 VDC	Yes	No	100 to 240 VAC (80 to 276 VAC) 60 to 250 VDC (48 to 300 VDC)

Table 8- 73 Electrical data: Current consumption and power loss

Device version (power supply)	Current consumption	Effective power loss
24 to 48 VDC	1.6 to 0.75 A	40 W
100 to 240 VAC / 60 to 250 VDC	0.6 to 0.37 A (AC) 0.7 to 0.17 A (DC)	42 W (AC) 42 W (DC)

Table 8- 74 Electrical data: Overcurrent protection

Device version (power supply)	Overcurrent protection of the power supply Non-replaceable fuse
1 x 24 to 48 VDC	1 x T2H / 250 V
2 x 24 to 48 VDC	2 x T2H / 250 V
1 x 100 to 240 VAC / 60 to 250 VDC	1 x T2H / 250 V (AC) 1 x T2H / 300 V (DC)
2 x 100 to 240 VAC / 60 to 250 VDC	2 x T2H / 250 V (AC) 2 x T2H / 300 V (DC)

Table 8- 75 Electrical data: Signaling contact

Device version (power supply)	Voltage via signaling contact	Switching capacity (resistive load)
24 to 48 VDC	24 VDC	max. 0.1 A
100 to 240 VAC / 60 to 250 VDC	240 VAC	max. 5 A
	60 VDC	max. 0.4 A
	125 VDC	max. 0.22 A
	250 VDC	max. 0.11 A

Table 8- 76 Plug-in terminal block for connectors of the power supply and signaling contact

Device version (power supply)	Power supply	Signaling contact
1 x 24 to 48 VDC	1 x 4-pin	1 x 2-pin
2 x 24 to 48 VDC	2 x 4-pin	2 x 2-pin
1 x 100 to 240 VAC / 60 to 250 VDC	1 x 3-pin	1 x 3-pin
2 x 100 to 240 VAC / 60 to 250 VDC	2 x 3-pin	2 x 3-pin

Table 8- 77 Overvoltage category

General	Overvoltage category II
In the application range of EN 60255-27	Overvoltage category III

8.6.3 Cable lengths

Table 8- 78 Permitted cable lengths (copper cable - Fast Ethernet)

Cable type	Accessory (plug, outlet, TP cord)	Permitted cable length
IE TP torsion cable	with IE FC Outlet RJ-45 + 10 m TP cord	0 to 45 m + 10 m TP cord
	with IE FC RJ-45 Plug 180	0 to 55 m
IE FC TP Marine Cable IE FC TP Trailing Cable IE FC TP Flexible Cable	with IE FC Outlet RJ-45 + 10 m TP cord	0 to 75 m + 10 m TP cord
	with IE FC RJ-45 Plug 180	0 to 85 m
IE FC TP standard cable	with IE FC Outlet RJ-45 + 10 m TP cord	0 to 90 m + 10 m TP cord
	with IE FC RJ-45 Plug 180	0 to 100 m

Table 8- 79 Permitted cable lengths (copper cable - gigabit Ethernet)

Cable type	Accessory (plug, outlet, TP cord)	Permitted cable length
IE FC Standard Cable, 4 × 2, 24 AWG IE FC Flexible Cable, 4 × 2, 24 AWG	with IE FC RJ-45 Plug 180, 4 × 2	0 to 90 m
IE FC Standard Cable, 4 × 2, 22 AWG	with IE FC Outlet RJ-45 + 10 m TP cord	0 to 60 m + 10 m TP cord
IE FC Flexible Cable, 4 × 2, 22 AWG	with IE FC Outlet RJ-45 + 10 m TP cord	0 to 90 m + 10 m TP cord

Note

Permitted cable lengths (fiber-optic cable - Fast Ethernet or gigabit)

The values correspond to those of the permitted MM900 media modules and SFP transceivers.

8.6.4 Block architecture

Block architecture with SCALANCE XR-300 devices

The XR324-12M and XR324-4M handle the Ethernet frame traffic of the 24 ports with the aid of three switch blocks.

- The three switch blocks are connected in series (block 1 via block 2 to block 3)
- Gigabit wire speed is possible within a block (max. 8 ports per block).
- Between the blocks there is a bandwidth of 1 gigabit/s available, that must be shared by all ports for frame traffic between the blocks.

When operating solely with Fast Ethernet (100 Mbps), the XR devices support full wire speed via all blocks.

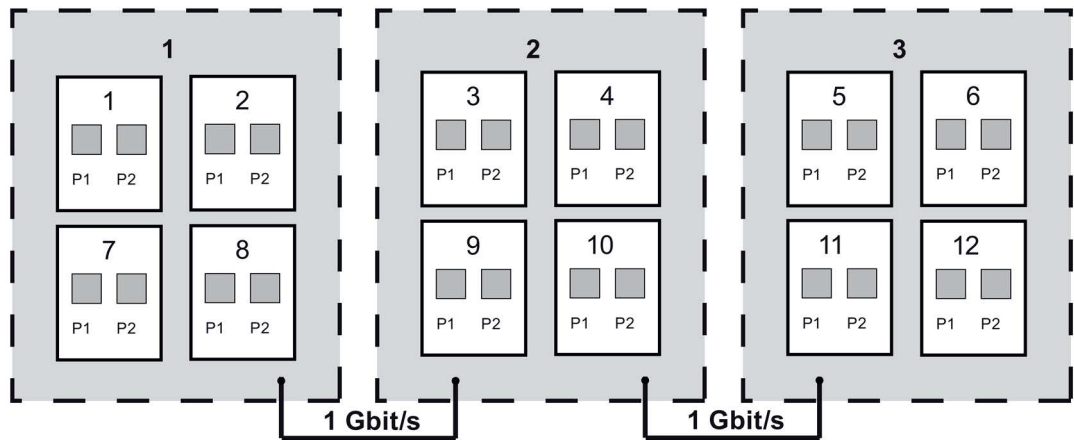

Image 8-3 Block architecture of the XR324-12M

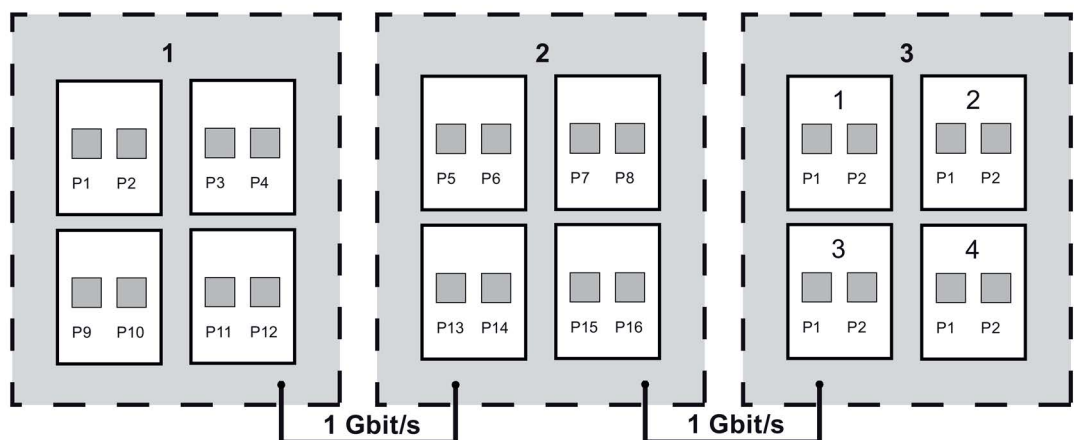

Image 8-4 Block architecture of the XR324-4M

8.6.5 Other properties

Table 8- 80 Switching properties

Max. number of learnable addresses	8000
Aging time	30 sec
Switching technique	Store and forward
Latency	5 µs

Table 8- 81 Reconfiguration times for redundancy mechanisms

Redundancy mechanism	Reconfiguration times
HRP	300 ms
Standby link	300 ms
MRP	200 ms

Mean time between failure (MTBF)

The values in the following table apply to the basic device without media modules.

Device version (power supply)	MTBF ¹⁾
1 x 24 to 48 VDC or 1 x 100 to 240 VAC / 60 to 250 VDC	> 15 years
2 x 24 to 48 VDC or 2 x 100 to 240 VAC / 60 to 250 VDC	> 15 years ²⁾

1) These values apply at 40 °C.

2) The redundant power supply unit increases the reliability of the system. The MTBF value of the power supply unit is > 20 years.

In the calculation of the MTBF of a modular switch, the standard parts count applies; in other words, the reciprocals of all component failure rates are added.

The reciprocal of this total is the MTBF of the entire assembly.

$$MTBF_{total} = \frac{1}{\left(\frac{1}{MTBF_{basic\ device}} + \frac{1}{MTBF_{module\ 1}} + \dots + \frac{1}{MTBF_{module\ n}} \right)}$$

Table 8- 82 Full wire speed switching

Number of frames per second		At a frame length of
At 100 Mbps	At 1000 Mbps	
148810	1488095	64 bytes
84459	844595	128 bytes
45290	452899	256 bytes

Number of frames per second		At a frame length of
At 100 Mbps	At 1000 Mbps	
23496	234962	512 bytes
11973	119732	1024 bytes
9615	96154	1280 bytes
8127	81274	1518 bytes

Note

The following applies to IE Switches X-300:

The number of IE Switches X-300 connected in a line influences the frame delay time. When a frame passes through the switch, this is delayed by the Store&Forward function of the IE Switch X-300 by the following values:

- at 64 bytes frame length: Delay of approx. 10 microseconds (at 100 Mbps)
- at 1500 bytes frame length: Delay of approx. 130 microseconds (at 100 Mbps)

This means, the more IE Switches X-300 a frame runs through, the higher the frame delay.

8.7 X-300M PoE technical specifications

Note

Validity of the technical specifications

All the technical specifications described in this section that is not assigned to a specific device variant, version or a media module, apply to all device variants/versions of the product group.

8.7.1 Construction, installation and environmental conditions

Table 8- 83 Construction

Dimensions (W x H x D)	120 × 125 × 124 mm
Weight	1150 g
Degree of protection	IP20

Table 8- 84 Installation options

Installation options	<ul style="list-style-type: none"> • DIN rail ¹⁾ • S7-300 standard rail • Wall
----------------------	--

¹⁾ Note: When used in shipbuilding, installation on a 35 mm DIN rail is not permitted. In ships, the 35 mm DIN rail does not provide adequate support.

Table 8- 85 Permitted ambient conditions

Storage/transport temperature	-40 °C to +85 °C
Max. relative humidity in operation at 25 °C	<= 95% (no condensation)
Max. ambient temperature at operating altitude	2000 m or above: -5 °C of the max. operating temperature ¹⁾ 3000 m or above: -10 °C of the max. operating temperature ¹⁾

¹⁾ See table: "Operating temperature depending on the media modules used"

Table 8- 86 Operating temperature depending on the media modules used

Media module ¹⁾	Installation direction	Operating temperature ²⁾
Without media module	Horizontal	-40 °C to +60 °C
	Vertical	-40 °C to +45 °C
MM992-2CUC MM992-2CUC (C) MM992-2CU MM992-2M12 (C) MM992-2VD MM991-2 MM991-2FM MM991-2LD MM991-2 (SC) MM991-2LD (SC) MM992-2 MM992-2 (C) MM992-2LD	Horizontal	-40 °C to +60 °C
	Vertical	-40 °C to +45 °C
MM991-2LH+ (SC) MM992-2LH MM992-2LH+ MM992-2ELH	Horizontal	-40 °C to +50 °C
	Vertical	-40 °C to +45 °C
Media module MM992-2SFP with pluggable transceiver SFP991-1 SFP991-1LD SFP992-1 SFP992-1LD	Horizontal	-40 °C to +60 °C
	Vertical	-40 °C to +45 °C

Media module ¹⁾	Installation direction	Operating temperature ²⁾
Media module MM992-2SFP with pluggable transceiver SFP991-1LH+ SFP992-1LH SFP992-1LH+ SFP992-1ELH SFP991-1ELH200	Horizontal	-40 °C to +50 °C
	Vertical	-40 °C to +45 °C
MM991-2P		- 25 °C to + 40 °C

- 1) Only hardware product version 02 of the media modules is permitted. The hardware product version is shown on the product. You can also read out this information from the device with the WBM or the CLI.
- 2) The permitted operating temperature depends on how the mounting device was installed. The installation is horizontal if the device labeling is from left to right. With a vertical installation, the device labeling is rotated through 90°.

8.7.2 Connectors and electrical data

Table 8- 87 Connection for end devices or network components

Max. number	8 ports
Electrical	4 x RJ-45 jacks, MDI-X pinning, 10/100/1000 Mbps (half/full duplex) power supply for connected devices (PDs) using Power over Ethernet (PoE) according to IEEE 802.3af / 802.3at (type 1)
Media module slots	2 x modular (2 ports per slot)
Transmitter output (optical) and receiver input	The values correspond to those of the permitted MM900 media modules and SFP transceivers.

Table 8- 88 Electrical data: Power supply

Rated voltage	Voltage range	Permitted voltage range including total ripple
24 VDC	19.2 VDC - 28.8 VDC	18.5 VDC - 30.2 VDC

Table 8- 89 Electrical data: Power consumption and redundancy

Current consumption	2 A
Max. power consumption (incl. PoE power supply of the connected PoE devices (PDs))	48 W
Power loss at 24 VDC	17 W

Overcurrent protection of the power supply Non-replaceable fuse	3 A / 32 V and 5 A / 125 V (PoE)
Redundant power supply unit	No
Redundant power supply possible	Yes

Table 8- 90 Electrical data: Signaling contact

Voltage via signaling contact	24 VDC
Switching capacity (resistive load)	max. 100 mA

Table 8- 91 Plug-in terminal block for connectors of the power supply and signaling contact

Power supply	1 x 4-pin male connector
Signaling contact	1 x 2-pin male connector

Table 8- 92 Power over Ethernet at port P1, P2, P3, P4

PoE function within a power supply system	According to IEEE 802.3af / 802.3at (type 1) for environment A
Method of PoE power feed	Alternative A (refer to the following table for the pin assignment)
Reserved power per port	15.4 W at port, of which the following can be used by the PD: 12.95 W
Overall power on all 4 ports	Max. 30.8 W

Table 8- 93 Electrical isolation

Between the ports	No
Between ports and ground	Yes
Between ports and 24 VDC power input	Yes

Table 8- 94 Pin assignment of the Ethernet ports of the SCALANCE PoE switch

Pin number / wire ¹⁾	Assignment for data transmission	Assignment for power transfer (PoE). Alternative A (MDI-X)
Pin 1	RX+	V-
Pin 2	RX-	V-
Pin 3	TX+	V+

Pin number / wire ¹⁾	Assignment for data transmission	Assignment for power transfer (PoE). Alternative A (MDI-X)
Pin 4	-	-
Pin 5	-	-
Pin 6	TX-	V+
Pin 7	-	-
Pin 8	-	-

¹⁾ with 4-wire industrial twisted-pair cables, the wires are connected to pins 1, 2, 3 and 6.

8.7.3 Cable lengths

Table 8- 95 Permitted cable lengths (copper cable - Fast Ethernet)

Cable type	Accessory (plug, outlet, TP cord)	Permitted cable length
IE TP torsion cable	with IE FC Outlet RJ-45 + 10 m TP cord	0 to 45 m + 10 m TP cord
	with IE FC RJ-45 Plug 180	0 to 55 m
IE FC TP Marine Cable IE FC TP Trailing Cable IE FC TP Flexible Cable	with IE FC Outlet RJ-45 + 10 m TP cord	0 to 75 m + 10 m TP cord
	with IE FC RJ-45 Plug 180	0 to 85 m
IE FC TP standard cable	with IE FC Outlet RJ-45 + 10 m TP cord	0 to 90 m + 10 m TP cord
	with IE FC RJ-45 Plug 180	0 to 100 m

Table 8- 96 Permitted cable lengths (copper cable - gigabit Ethernet)

Cable type	Accessory (plug, outlet, TP cord)	Permitted cable length
IE FC Standard Cable, 4 × 2, 24 AWG IE FC Flexible Cable, 4 × 2, 24 AWG	with IE FC RJ-45 Plug 180, 4 × 2	0 to 90 m
IE FC Standard Cable, 4 × 2, 22 AWG	with IE FC Outlet RJ-45 + 10 m TP cord	0 to 60 m + 10 m TP cord
IE FC Flexible Cable, 4 × 2, 22 AWG	with IE FC Outlet RJ-45 + 10 m TP cord	0 to 90 m + 10 m TP cord

Cable type	Accessory (plug, outlet, TP cord)	Permitted cable length
------------	-----------------------------------	------------------------

Note

Permitted cable lengths (fiber-optic cable - Fast Ethernet or gigabit)

The values correspond to those of the permitted MM900 media modules and SFP transceivers.

8.7.4 Other properties

Table 8- 97 Switching properties

Max. number of learnable addresses	8000
Aging time	30 sec
Switching technique	Store and forward
Latency	5 μs

Table 8- 98 Reconfiguration times for redundancy mechanisms

Redundancy mechanism	Reconfiguration times
HRP	300 ms
Standby link	300 ms
MRP	200 ms

Mean time between failure (MTBF)

The value in the following table applies to the basic device without media modules.

MTBF	> 30 years ¹⁾
------	--------------------------

¹⁾ This value applies at 40 °C.

In the calculation of the MTBF of a modular switch, the standard parts count applies; in other words, the reciprocals of all component failure rates are added.

The reciprocal of this total is the MTBF of the entire assembly.

$$MTBF_{total} = \frac{1}{\left(\frac{1}{MTBF_{basic\ device}} + \frac{1}{MTBF_{module\ 1}} + \dots + \frac{1}{MTBF_{module\ n}} \right)}$$

Note

The IE Switches X-300 support "full wire speed switching" complying with IEEE 802.3 on all ports. The number of packets therefore depends on the packet length.

Table 8- 99 Full wire speed switching

Number of frames per second		At a frame length of
At 100 Mbps	At 1000 Mbps	
148810	1488095	64 bytes
84459	844595	128 bytes
45290	452899	256 bytes
23496	234962	512 bytes
11973	119732	1024 bytes
9615	96154	1280 bytes
8127	81274	1518 bytes

Note

The following applies to IE Switches X-300:

The number of IE Switches X-300 connected in a line influences the frame delay time. When a frame passes through the switch, this is delayed by the Store&Forward function of the IE Switch X-300 by the following values:

- at 64 bytes frame length: Delay of approx. 10 microseconds (at 100 Mbps)
- at 1500 bytes frame length: Delay of approx. 130 microseconds (at 100 Mbps)

This means, the more IE Switches X-300 a frame runs through, the higher the frame delay.

8.8 XR-300M PoE technical specifications

Note**Validity of the technical specifications**

All the technical specifications described in this section that is not assigned to a specific device variant, version or a media module, apply to all device variants/versions of the product group.

8.8.1 Construction, installation and environmental conditions

Table 8- 100 Construction

Dimensions (W x H x D)	449 × 43.6 × 305 mm
Weight	6800 g
Degree of protection	IP20 (with closed service panel)

Table 8- 101 Installation options

Device version (power supply)	Installation options
24 VDC	<ul style="list-style-type: none"> • 19" rack • Desktop operation with adhesive feet
100 to 240 VAC	19" rack

Table 8- 102 Permitted ambient conditions

Storage/transport temperature	-40 °C to +85 °C
Max. relative humidity in operation at 25 °C	<= 95% (no condensation)
Max. ambient temperature at operating altitude	2000 m or above: -5 °C of the max. operating temperature ¹⁾ 3000 m or above: -10 °C of the max. operating temperature ¹⁾

1) See table: "Operating temperature depending on the media modules used"

Table 8- 103 Operating temperature depending on the media modules used

Media module ¹⁾	Installation direction	Operating temperature ²⁾
Without media module	Horizontal	-40 °C to +60 °C
	Vertical	-40 °C to +50 °C
MM992-2CUC MM992-2CUC (C) MM992-2CU MM992-2M12 (C) MM992-2VD MM991-2 MM991-2FM MM991-2LD MM991-2 (SC) MM991-2LD (SC) MM992-2 MM992-2 (C) MM992-2LD	Horizontal	-40 °C to +60 °C
	Vertical	-40 °C to +50 °C

Media module ¹⁾	Installation direction	Operating temperature ²⁾
MM991-2LH+ (SC) MM992-2LH MM992-2LH+ MM992-2ELH	Horizontal	Maximum 2 modules in slots 3 and 4: -40 °C ... +60 °C With more than 2 modules or other slot assignment: -40 °C to +50 °C
	Vertical	-40 °C to +50 °C
Media module MM992-2SFP with pluggable transceiver SFP991-1 SFP991-1LD SFP992-1 SFP992-1LD	Horizontal	-40 °C to +60 °C
	Vertical	-40 °C to +50 °C
Media module MM992-2SFP with pluggable transceiver SFP991-1LH+ SFP992-1LH SFP992-1LH+ SFP992-1ELH SFP991-1ELH200	Horizontal	Maximum 2 modules in slots 3 and 4: -40 °C ... +60 °C With more than 2 modules or other slot assignment: -40 °C to +50 °C
	Vertical	-40 °C to +50 °C
MM991-2P		Maximum 2 modules in slots 3 and 4: The slot above an MM991-2P may be used as follows: <ul style="list-style-type: none"> • Without media module: - 25 °C to + 50 °C • With media module MM992-2CUC or MM992-2CU: - 25 °C to + 40 °C

- 1) Only hardware product version 02 of the media modules is permitted.
The hardware product version is shown on the product. You can also read out this information from the device with the WBM or the CLI.
- 2) The permitted operating temperature depends on how the mounting device was installed. The installation is horizontal if the device labeling is from left to right. With a vertical installation, the device labeling is rotated through 90°.

8.8.2 Connectors and electrical data

Table 8- 104 Connection for end devices or network components

Max. number	24 ports
Electrical	Port 1 to 8 8 x RJ-45 jacks, MDI-X pinning, 10/100/1000 Mbps (half/full duplex) power supply for connected devices (PDs) using Power over Ethernet (PoE) according to IEEE 802.3af / 802.3at (type 1) Port 9 to 16: 8 x RJ-45 jacks with MDI-X assignment 10/100/1000 Mbps (half / full duplex)
Media module slots	4 x modular (2 ports per slot)
Transmitter output (optical) and receiver input	The values correspond to those of the permitted MM900 media modules and SFP transceivers.
Diagnostics port	RJ-11 jack

Table 8- 105 Electrical data: Power supply

Device version (power supply)	Redundant power supply unit	Redundant power supply possible	Power supply	
			Rated voltage	24 VDC
24 VDC	No	Yes	Voltage range	19.2 VDC - 28.8 VDC
			Permitted voltage range incl. total ripple	18.5 VDC - 30.2 VDC
100 to 240 VAC	No	No	100 to 240 VAC (85 to 264 V)	

Table 8- 106 Electrical data: Current consumption and power loss

Device version (power supply)	Current consumption	Effective power loss	Max. power consumption ¹⁾
24 VDC	4.2 A	46 W	100 W
100 to 240 VAC	1,3 ... 0.7 A	42 W	96 W

¹⁾ incl. PoE power supply of the connected PoE devices (PDs)

Table 8- 107 Electrical data: Overcurrent protection

Device version (power supply)	Overcurrent protection of the power supply Non-replaceable fuse
24 VDC	T 5 A / 250 V
100 to 240 VAC	T 2 A / 500 V

Table 8- 108 Electrical data: Signaling contact

Voltage via signaling contact	24 VDC
Switching capacity (resistive load)	max. 100 mA

Table 8- 109 Plug-in terminal block for connectors of the power supply and signaling contact

Device version (power supply)	Power supply	Signaling contact
24 VDC	1 x 4-pin	1 x 2-pin
100 to 240 VAC	1 x 2-pin	1 x 2-pin

Table 8- 110 Power over Ethernet at port P1 to P8

PoE function within a power supply system	According to IEEE 802.3af / 802.3at (type 1) for environment A
Method of PoE power feed	Alternative A (refer to the following table for the pin assignment)
Reserved power per port	15.4 W at port, of which the following can be used by the PD: 12.95 W
Overall power on all PoE ports	Max. 53.2 W

Table 8- 111 Electrical isolation

Between ports P1 to P8	No
Between ports P9 to P16	Yes
Between port groups P1 to P8 and P9 to P16	Yes
Between ports and ground	Yes
Between ports and 24 VDC / 230 VAC power input	Yes

Table 8- 112 Pin assignment of the Ethernet ports of the SCALANCE PoE switch

Pin number / wire ¹⁾	Assignment for data transmission	Assignment for power transfer (PoE). Alternative A (MDI-X)
Pin 1	RX+	V-
Pin 2	RX-	V-
Pin 3	TX+	V+
Pin 4	-	-
Pin 5	-	-
Pin 6	TX-	V+
Pin 7	-	-
Pin 8	-	-

¹⁾ with 4-wire industrial twisted-pair cables, the wires are connected to pins 1, 2, 3 and 6.

8.8.3 Cable lengths

Table 8- 113 Permitted cable lengths (copper cable - Fast Ethernet)

Cable type	Accessory (plug, outlet, TP cord)	Permitted cable length
IE TP torsion cable	with IE FC Outlet RJ-45 + 10 m TP cord	0 to 45 m + 10 m TP cord
	with IE FC RJ-45 Plug 180	0 to 55 m
IE FC TP Marine Cable IE FC TP Trailing Cable IE FC TP Flexible Cable	with IE FC Outlet RJ-45 + 10 m TP cord	0 to 75 m + 10 m TP cord
	with IE FC RJ-45 Plug 180	0 to 85 m
IE FC TP standard cable	with IE FC Outlet RJ-45 + 10 m TP cord	0 to 90 m + 10 m TP cord
	with IE FC RJ-45 Plug 180	0 to 100 m

Table 8- 114 Permitted cable lengths (copper cable - gigabit Ethernet)

Cable type	Accessory (plug, outlet, TP cord)	Permitted cable length
IE FC Standard Cable, 4 × 2, 24 AWG IE FC Flexible Cable, 4 × 2, 24 AWG	with IE FC RJ-45 Plug 180, 4 × 2	0 to 90 m
IE FC Standard Cable, 4 × 2, 22 AWG	with IE FC Outlet RJ-45 + 10 m TP cord	0 to 60 m + 10 m TP cord
IE FC Flexible Cable, 4 × 2, 22 AWG	with IE FC Outlet RJ-45 + 10 m TP cord	0 to 90 m + 10 m TP cord

Cable type	Accessory (plug, outlet, TP cord)	Permitted cable length
------------	-----------------------------------	------------------------

Note

Permitted cable lengths (fiber-optic cable - Fast Ethernet or gigabit)

The values correspond to those of the permitted MM900 media modules and SFP transceivers.

8.8.4 Block architecture

Block architecture of the SCALANCE XR-300M PoE

The XR-300M PoE handles the Ethernet frame traffic of the 24 ports with the aid of three switch blocks.

- The three switch blocks are connected in series (block 1 via block 2 to block 3).
- Gigabit wire speed is possible within a block (max. 8 ports per block).
- Between the blocks there is a bandwidth of 1 gigabit/s available, that must be shared by all ports for frame traffic between the blocks.

When operating solely with Fast Ethernet (100 Mbps), the XR devices support full wire speed via all blocks.

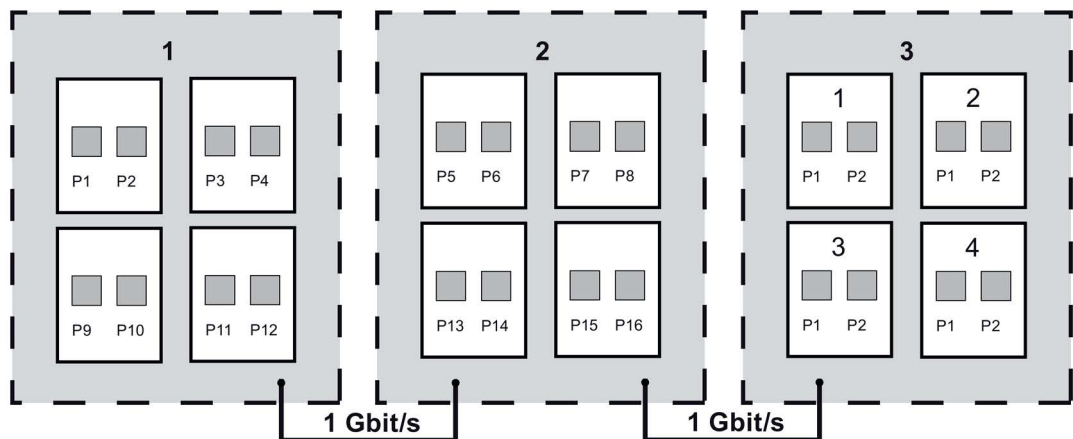

Image 8-5 Block architecture of the XR324-4M

8.8.5 Other properties

Table 8- 115 Switching properties

Max. number of learnable addresses	8000
Aging time	30 sec
Switching technique	Store and forward
Latency	5 μs

Table 8- 116 Reconfiguration times for redundancy mechanisms

Redundancy mechanism	Reconfiguration times
HRP	300 ms
Standby link	300 ms
MRP	200 ms

Mean time between failure (MTBF)

The value in the following table applies to the basic device without media modules.

MTBF	> 15 years ¹⁾
------	--------------------------

¹⁾ This value applies at 40 °C.

In the calculation of the MTBF of a modular switch, the standard parts count applies; in other words, the reciprocals of all component failure rates are added.

The reciprocal of this total is the MTBF of the entire assembly.

$$MTBF_{total} = \frac{1}{\left(\frac{1}{MTBF_{basic\ device}} + \frac{1}{MTBF_{module\ 1}} + \dots + \frac{1}{MTBF_{module\ n}} \right)}$$

Table 8- 117 Full wire speed switching

Number of frames per second		At a frame length of
At 100 Mbps	At 1000 Mbps	
148810	1488095	64 bytes
84459	844595	128 bytes
45290	452899	256 bytes
23496	234962	512 bytes
11973	119732	1024 bytes
9615	96154	1280 bytes
8127	81274	1518 bytes

Number of frames per second		At a frame length of
At 100 Mbps	At 1000 Mbps	

Note

The following applies to IE Switches X-300:

The number of IE Switches X-300 connected in a line influences the frame delay time. When a frame passes through the switch, this is delayed by the Store&Forward function of the IE Switch X-300 by the following values:

- at 64 bytes frame length: Delay of approx. 10 microseconds (at 100 Mbps)
- at 1500 bytes frame length: Delay of approx. 130 microseconds (at 100 Mbps)

This means, the more IE Switches X-300 a frame runs through, the higher the frame delay.

8.9 MM900 technical specifications

Note

Validity of the technical specifications

All the technical specifications described in this section that are not specific to a product version, apply to the MM900 media module.

8.9.1 Construction, installation and environmental conditions

Table 8- 118 Construction

Dimensions (W x H x D)	60 × 22 × 100 mm
Weight	80 g

Table 8- 119 Operating temperature depending on the media modules used ^{1) 2)}

Type	Installation location	Without media module	MM992-2CUC MM992-2CUC (C) MM992-2CU MM992-2M12 (C) MM992-2VD MM991-2 MM991-2FM MM991-2LD MM991-2 (SC) MM991-2LD (SC) MM992-2 MM992-2 (C) MM992-2LD	MM991-2LH+ (SC) MM992-2LH MM992-2LH+ MM992-2ELH	Media module MM992-2SFP with SFP transceiver SFP991-1 SFP991-1LD SFP992-1 SFP992-1LD	Media module MM992-2SFP with SFP transceiver SFP991-1LH+ SFP992-1LH SFP992-1LH+ SFP992-1ELH SFP991-1ELH200
X-300M	Horizontal	-40 °C to +70 °C			-40 °C to +60 °C	
	Vertical	-40 °C to +50 °C				
X-300M PoE	Horizontal	-40 °C to +60 °C		-40 °C to +50 °C	-40 °C to +60 °C	-40 °C to +50 °C
	Vertical	-40 °C to +45 °C				
XR-300M	Horizontal	Not possible (fully modular device)	-40 °C to +70 °C	Maximum 2 modules in slots 11 and 12: -40 °C to +60 °C With more than 2 modules or other slot assignment: -40 °C to +50 °C	-40 °C to +60 °C	Maximum 2 modules in slots 11 and 12: -40 °C to +60 °C With more than 2 modules or other slot assignment: -40 °C to +50 °C
	Vertical	Not possible (fully modular device)	-40 °C to +50 °C			
XR-300M PoE	Horizontal	-40 °C to +60 °C		Maximum 2 modules in slots 3 and 4: -40 °C ... +60 °C With more than 2 modules or other slot assignment: -40 °C to +50 °C	-40 °C to +60 °C	Maximum 2 modules in slots 3 and 4: -40 °C to +60 °C With more than 2 modules or other slot assignment: -40 °C to +50 °C
	Vertical	-40 °C to +50 °C				
XR-300M EEC	Horizontal	-40 °C to +70 °C		Maximum 2 modules in slots 3 and 4: -40 °C ... +60 °C With more than 2 modules or other slot assignment: -40 °C to +50 °C	-40 °C to +70 °C SFP transceivers of this group can only be used in conjunction with media modules MM992-2CUC, MM992-2CUC (C) and MM992-2CU. When using other modules: -40 °C to +60 °C	Maximum 2 modules in slots 3 and 4: -40 °C to +60 °C With more than 2 modules or other slot assignment: -40 °C to +50 °C
	Vertical	-40 °C to +50 °C				

Type	Installation location	Without media module	MM992-2CUC MM992-2CUC (C) MM992-2CU MM992-2M12 (C) MM992-2VD MM991-2 MM991-2FM MM991-2LD MM991-2 (SC) MM991-2LD (SC) MM992-2 MM992-2 (C) MM992-2LD	MM991-2LH+ (SC) MM992-2LH MM992-2LH+ MM992-2ELH	Media module MM992-2SFP with SFP transceiver SFP991-1 SFP991-1LD SFP992-1 SFP992-1LD	Media module MM992-2SFP with SFP transceiver SFP991-1LH+ SFP992-1LH SFP992-1LH+ SFP992-1ELH SFP991-1ELH200
------	-----------------------	----------------------	--	--	--	---

- 1) Only hardware product version 02 of the media modules is permitted.
The hardware product version is shown on the product. You can also read out this information from the device with the WBM or the CLI.
- 2) The permitted operating temperature depends on how the mounting device was installed. The installation is horizontal if the device labeling is from left to right. With a vertical installation, the device labeling is rotated through 90°.

Table 8- 120 Operating temperature with media module MM991-2P

Type	Operating temperature
X-300M X-300M PoE	<ul style="list-style-type: none"> • - 25 °C to + 40 °C
XR-300M XR-300M PoE XR-300M EEC	<p>The slot above an MM991-2P may be used as follows:</p> <ul style="list-style-type: none"> • Without media module: - 25 °C to + 50 °C) • With media module MM992-2CUC or MM992-2CU: - 25 °C to + 40 °C) <p>Note the information under "MM991-2P product characteristics".</p>

Table 8- 121 Permitted ambient conditions

Storage/transport temperature	-40 °C to +85 °C
Max. relative humidity in operation at 25 °C	<= 95% (no condensation)
Max. ambient temperature at operating altitude	As of 2000 m: -5 °C of the max. operating temperature ¹⁾ As of 3000 m: -10 °C of the max. operating temperature ¹⁾

1) See table: "Operating temperature depending on the media modules used"

8.9.2 Connectors and electrical data

Table 8- 122 Interfaces

Media module	Interfaces
MM992-2CUC	2 x 10/100/1000 Mbps, RJ-45 ports electrical with securing collar
MM992-2CUC (C)	2 x 10/100/1000 Mbps, RJ-45 ports electrical with securing collar, varnished
MM992-2CU	2 x 10/100/1000 Mbps, RJ-45 port electrical without securing collar
MM992-2M12 (C)	2 x 10/100/1000 Mbps, GE M12 connector electrical
MM992-2VD	2 x 10/100/1000 Mbps, RJ-45 ports electrical with securing collar
MM991-2	2 x 100 Mbps, BFOC ports optical, multimode FO cable, up to max. 5 km
MM991-2FM	2 x 100 Mbps, BFOC port optical, for glass FO cable (multimode) with diagnostics up to max. 5 km
MM991-2LD	2 x 100 Mbps, BFOC ports optical, single mode FO cable, up to max. 26 km
MM991-2 (SC)	2 x 100 Mbps, SC ports optical, multimode FO cable, up to max. 5 km
MM991-2LD (SC)	2 x 100 Mbps, SC ports optical, single mode FO cable, up to max. 26 km
MM991-2LH+ (SC)	2 x 100 Mbps, SC ports optical, single mode FO cable, up to max. 70 km
MM991-2P	2 x 100 Mbps SC RJ ports optical for Plastic Optical Fiber (POF) up to max. 50 m or Polymer Cladded Fiber (PCF) up to max. 100 m
MM992-2	2 x 1000 Mbps, SC ports optical, multimode FO cable, up to max. 750 m
MM992-2 (C)	2 x 1000 Mbps, SC ports optical, multimode FO cable, up to max. 750 m, varnished
MM992-2LD	2 x 1000 Mbps, SC ports optical, single mode FO cable, up to max. 10 km
MM992-2LH	2 x 1000 Mbps, SC ports optical, single mode FO cable, up to max. 40 km
MM992-2LH+	2 x 1000 Mbps, SC ports optical, single mode FO cable, up to max. 70 km
MM992-2ELH	2 x 1000 Mbps, SC ports optical, single mode FO cable, up to max. 120 km
MM992-2SFP ¹⁾	2 x 100/1000 Mbps, SFP media module, optical LC ports with corresponding SFP transceivers.

Table 8- 123 Power supply

Power supply	(24 VDC SELV) The media modules are supplied with power by the SCALANCE device. No other power supply is permitted.
--------------	--

Table 8- 124 Electrical data: Current consumption and power loss I

Media module	Current consumption	Effective power loss
MM992-2CUC	70 mA	1.65 W
MM992-2CUC (C)	70 mA	1.65 W
MM992-2CU	70 mA	1.65 W
MM992-2M12 (C)	70 mA	1.65 W
MM992-2VD	70 mA	1.65 W
MM991-2	100 mA	2.42 W
MM991-2FM	100 mA	2.42 W
MM991-2LD	80 mA	2.04 W
MM991-2 (SC)	100 mA	2.42 W
MM991-2LD (SC)	80 mA	2.04 W
MM991-2LH+ (SC)	80 mA	2.04 W
MM991-2P	140 mA	3.36 W
MM992-2	70 mA	1.76 W
MM992-2 (C)	70 mA	1.76 W
MM992-2LD	80 mA	1.95 W
MM992-2LH	90 mA	2.11 W
MM992-2LH+	100 mA	2.42 W
MM992-2ELH	110 mA	2.75 W

Table 8- 125 Electrical data: Current consumption and power loss II

MM992-2SFP with	Current consumption	Effective power loss
SFP991-1	60 mA	1.54 W
SFP991-1LD	60 mA	1.54 W
SFP991-1LH+	70 mA	1.65 W
SFP992-1	60 mA	1.38 W
SFP992-1LD	70 mA	1.60 W
SFP992-1LH	70 mA	1.71 W
SFP992-LH+	80 mA	1.93 W
SFP992-1ELH	100 mA	2.31 W
SFP991-1ELH200	100 mA	2.31 W

Note

Fusing and signal contacts with media modules

The MM900 media modules do not have their own fuses and have no signaling contacts. The fuses and the signaling contacts exist in the SCALANCE device.

Table 8- 126 Electrical data: Transmitter output (optical) and receiver input

Media module	Transmitter output (optical)		Receiver input	
	min. [dBm]	max. [dBm]	Sensitivity min. [dBm]	Input power max. [dBm]
MM992-2CUC	-	-	-	-
MM992-2CUC (C)	-	-	-	-
MM992-2CU	-	-	-	-
MM992-2M12 (C) ²⁾	-	-	-	-
MM992-2VD	-	-	-	-
MM991-2	-19	-14	-32	-3
MM991-2FM	-19	-14	-32	-3
MM991-2LD	-15	-8	-34	-3
MM991-2 (SC)	-19	-14	-34	-3
MM991-2LD (SC)	-15	-8	-32	-3
MM991-2LH+ (SC)	-5	0	-34	-3
MM991-2P	-8	-2	-23	+1
MM992-2	-9.5	-4	-17	-3
MM992-2 (C)	-9.5	-4	-17	-3
MM992-2LD	-9.5	-3	-21	-3
MM992-2LH	-6	0	-23	-3
MM992-2LH+	0	5	-23	-3
MM992-2ELH	0	5	-30	-3
MM992-2SFP ¹⁾	-	-	-	-

1) You will find further information in the compact operating instructions "Transceiver SFP/SFP+".

2) The ports of the MM992-2M12 (C) only meet the requirements according to Environment A (IEEE 802.3), in other words, the electrical isolation of the ports is designed for 500 Vrms (1 minute).

8.9.3 Cable lengths

Copper cables

Table 8- 127 Permitted cable lengths (copper cable - Fast Ethernet)

Media module	Cable	Permitted cable length
MM992-2CUC	IE TP torsion cable with	0 to 45 m
MM992-2CUC (C)	IE FC Outlet RJ-45 + 10 m TP cord	+ 10 m TP cord
MM992-2CU	IE TP torsion cable	0 to 55 m
MM992-2M12 (C)	with IE FC RJ-45 Plug 180	
MM992-2VD (without VD) ¹⁾	IE FC TP marine/trailing/flexible cable with IE FC Outlet RJ-45 + 10 m TP cord	0 to 75 m + 10 m TP cord

Media module	Cable	Permitted cable length
	IE FC TP marine/trailing/ flexible cable with IE FC RJ-45 Plug 180	0 to 85 m
	IE FC TP standard cable with IE FC Outlet RJ-45 + 10 m TP cord	0 to 90 m + 10 m TP cord
	IE FC TP standard cable with IE FC RJ-45 plug 180	0 to 100 m
MM992-2VD (with VD) ²⁾	IE FC TP standard cable GP 4X2 (24 AWG) with IE FC RJ-45 plug 4x2	0 to 500 m at 100 Mbps
	IE FC TP standard cable GP 2x2 with IE FC RJ-45 plug 2x2	0 to 300 m at 100 Mbps.
	IE FC TP standard cable GP 2x2 with IE FC RJ-45 plug 2x2	300 to 500 m at 10 Mbps
	PROFIBUS FC standard cable GP with IE FC RJ-45 plug 4x2	100 to 1000 m at 10 Mbps
	PROFIBUS FC standard cable GP with IE FC RJ-45 plug 4x2	0 to 100 m at 100 Mbps.

1) The VD mode (Variable Distance) is turned off.

2) The VD mode (Variable Distance) is turned on.

Table 8- 128 Permitted cable lengths (copper cable - gigabit Ethernet)

Media module	Cable	Permitted cable length
MM992-2CUC MM992-2CUC (C) MM992-2CU MM992-2M12 (C) MM992-2VD (without VD) ^{1) 2)}	IE FC standard cable, 4x2, 24 AWG IE FC flexible cable, 4x2, 24 AWG with IE FC RJ-45 Plug 180, 4x2	0 to 90 m
	IE FC standard cable, 4x2, 22 AWG with IE FC Outlet RJ-45 + 10 m TP cord	0 to 60 m + 10 m TP cord
	IE FC flexible cable, 4x2, 22 AWG with IE FC Outlet RJ-45 + 10 m TP cord	0 to 90 m + 10 m TP cord

1) The VD mode (Variable Distance) is turned off.

2) If the VD mode is turned on, the speed is reduced to 100 Mbps. For permitted cable lengths, see table Fast Ethernet.

Fiber-optic cables

Table 8- 129 Permitted cable lengths (fiber-optic cable - Fast Ethernet)

Media module	Fiber-optic cable type	Max. permitted cable length	Attenuation
MM991-2	50/125 µm multimode fiber	5 km	≤1 dB/km at 1310 nm; 1200 MHz×km; maximum insertion loss 0.5 dB; 9 dB max. permitted FO cable attenuation at 3 dB link power margin
	62.5/125 µm multi-mode fiber	5 km	≤1 dB/km at 1310 nm; 1200 MHz×km; maximum insertion loss 0.5 dB; 9 dB max. permitted FO cable attenuation at 3 dB link power margin
MM991-2FM	50/125 µm multimode fiber	5 km	≤1 dB/km at 1310 nm; 1200 MHz×km; maximum insertion loss 0.5 dB; 9 dB max. permitted FO cable attenuation at 3 dB link power margin
	62.5/125 µm multi-mode fiber	5 km	≤1 dB/km at 1310 nm; 1200 MHz×km; maximum insertion loss 0.5 dB; 9 dB max. permitted FO cable attenuation at 3 dB link power margin
MM991-2LD	9/125 µm single mode fiber	26 km	≤0.5 dB/km at 1310 nm; maximum insertion loss 0.5 dB; 14 dB max. permitted FO cable attenuation at 2 dB link power margin
MM991-2 (SC)	50/125 µm multimode fiber	5 km	≤1 dB/km at 1310 nm; 1200 MHz×km; maximum insertion loss 0.5 dB; 9 dB max. permitted FO cable attenuation at 3 dB link power margin
	62.5/125 µm multi-mode fiber	5 km	≤1 dB/km at 1310 nm; 1200 MHz×km; maximum insertion loss 0.5 dB; 9 dB max. permitted FO cable attenuation at 3 dB link power margin
MM991-2LD (SC)	9/125 µm single mode fiber	26 km	≤0.5 dB/km at 1310 nm; maximum insertion loss 0.5 dB; 14 dB max. permitted FO cable attenuation at 2 dB link power margin
MM991-2LH+ (SC)	9/125 µm single mode fiber	70 km	≤0.28 dB/km at 1550 nm; maximum insertion loss 0.5 dB; 26 dB max. permitted FO cable attenuation at 2 dB link power margin, minimum cable attenuation 3 dB
MM991-2P	980/1000 plastic optical fiber	50 m	9 dB max. permitted FO cable attenuation with 3 dB link power margin
	200/230 polymer cladded fiber	100 m	6 dB max. permitted FO cable attenuation with 3 dB link power margin

Table 8- 130 Permitted cable lengths (fiber-optic cable - gigabit Ethernet)

Media module	Fiber-optic cable type	Max. permitted cable length	Attenuation
MM992-2 MM992-2 (C)	62.5/125 µm multimode fiber	350 m	≤3.1 dB/km at 850 nm; 1200 MHz×km; maximum insertion loss 0.5 dB; 4.5 dB max. permitted FO cable attenuation at 3 dB link power margin
	50/125 µm multimode fiber	750 m	≤2.5 dB/km at 850 nm; 1200 MHz×km; maximum insertion loss 0.5 dB; 4.5 dB max. permitted FO cable attenuation at 3 dB link power margin

Media module	Fiber-optic cable type	Max. permitted cable length	Attenuation
MM992-2LD	9/125 µm single mode fiber	10 km	≤0.5 dB/km at 1310 nm; maximum insertion loss 0.5 dB; 6 dB max. permitted FO cable attenuation at 3 dB link power margin
MM992-2LH	9/125 µm single mode fiber	40 km	≤0.4 dB/km at 1550 nm; maximum insertion loss 0.5 dB; 18 dB max. permitted FO cable attenuation at 2 dB link power margin, minimum cable attenuation 3 dB
MM992-2LH+	9/125 µm single mode fiber	70 km	≤0.28 dB/km at 1550 nm; maximum insertion loss 0.5 dB; 21 dB max. permitted FO cable attenuation at 2 dB link power margin, minimum cable attenuation 8 dB
MM992-2ELH	9/125 µm single mode fiber	120 km	≤0.225 dB/km at 1550 nm; maximum insertion loss 0.5 dB; 27 dB max. permitted FO cable attenuation at 2 dB link power margin, minimum cable attenuation 8 dB

Copper / fiber-optic cables

Table 8- 131 Permitted cable lengths (copper cable/fiber-optic cable) for the SFP media module

Media module	Max. permitted cable length
MM992-2SFP ^{*)}	Depending on the SFP transceiver used.

^{*)} You will find further information in the compact operating instructions "Transceiver SFP/SFP+".

Attenuators

Transceivers of the types LH, LH+, ELH and ELH200 are designed for long distances and therefore send more power than they can receive.

If you establish a connection between such transceivers with a short cable length, use attenuators. Attenuators increase the attenuation and therefore protect the receiving diode.

Select the attenuation so that the transmit power (transmitter output) behind the attenuator is lower than the maximum received power (input power):

$$\text{Transmitter output max. [dBm]} - \text{attenuator [dB]} < \text{input power max. [dBm]}$$

Recommendation for the attenuation of the attenuator on a connection with the same transceivers:

Transceiver type	Attenuator
LH	6 dB ... 12 dB
LH+	12 dB ... 20 dB
ELH, ELH200	16 dB ... 24 dB

If you have established a connection on a pluggable transceiver with a short cable length, it is possible that the transmitter will be turned off. In this case, pull the transceiver and plug it in again.

GI-PCF

For segment lengths longer than 100 m, you can use GI-PCF cables. Note the information of the manufacturer.

8.9.4 Other properties

Table 8- 132 Mean time between failure (MTBF)

Device version (power supply)	MTBF ¹⁾
MM992-2CUC, MM992-2CUC (C), MM992-2CU, MM992-2M12 (C)	> 250 years
MM991-2P	> 230 years
MM992-2VD	> 200 years
MM991-2, MM991-2 (SC)	> 140 years
MM991-2FM MM992-2 (C)	> 135 years
MM991-2LD, MM991-2LD (SC), MM992-2LD	> 115 years
MM991-2LH+, MM992-2LH. MM992-2LH+	> 105 years
MM992-2ELH	> 95 years
MM992-2SFP ²⁾	> 250 years ³⁾

1) These values apply at 40 °C

2) You will find further information in the compact operating instructions "Transceiver SFP/SFP+".

3) empty

8.10 SFP technical specifications

8.10.1 Construction, installation and environment

Table 8- 133 Construction

Device: Transceiver	(Variant)	Dimensions (W x H x D) [in mm]	Weight [in g]	IP degree of protec- tion
SFP991-1	(1 x 100 Mbps, LC port optical, multimode glass, up to max. 3 km)	13.7 x 11.9 x 56.5	20	IP20
SFP991-1LD	(1 x 100 Mbps, LC port optical, single mode glass, up to max. 26 km)	13.7 x 11.9 x 56.5	20	IP20
SFP991-1LH+	(1 x 100 Mbps, LC port optical, single mode glass, up to max. 70km)	13.7 x 11.9 x 56.5	20	IP20
SFP992-1	(1 x 1000 Mbps, LC port optical, multimode glass, up to max. 750m)	13.7 x 11.9 x 56.5	20	IP20
SFP992-1LD	(1 x 1000 Mbps, LC port optical, single mode glass, up to max. 10km)	13.7 x 11.9 x 56.5	20	IP20
SFP992-1LH	(1 x 1000 Mbps, LC port optical, single mode glass, up to max. 40km)	13.7 x 11.9 x 56.5	20	IP20
SFP992-LH+	(1 x 1000 Mbps, LC port optical, single mode glass, up to max. 70km)	13.7 x 11.9 x 56.5	20	IP20
SFP992-1ELH	(1 x 1000 Mbps, LC port optical, single mode glass, up to max. 120km)	13.7 x 11.9 x 56.5	20	IP20

Table 8- 134 Installation options (modular)

Device: Transceiver	(Variant)	Modular installation options:	
		Media module installation in slot	SFP installation in SFP media module
SFP991-1	(1 x 100 Mbps, LC port optical, multimode glass, up to max. 3 km)	-	•
SFP991-1LD	(1 x 100 Mbps, LC port optical, single mode glass, up to max. 26 km)	-	•
SFP991-1LH+	(1 x 100 Mbps, LC port optical, single mode glass, up to max. 70km)	-	•

8.10 SFP technical specifications

Device: Transceiver	(Variant)	Modular installation options:	
		Media module installation in slot	SFP installation in SFP media module
SFP992-1	(1 x 1000 Mbps, LC port optical, multimode glass, up to max. 750m)	-	•
SFP992-1LD	(1 x 1000 Mbps, LC port optical, single mode glass, up to max. 10km)	-	•
SFP992-1LH	(1 x 1000 Mbps, LC port optical, single mode glass, up to max. 40km)	-	•
SFP992-LH+	(1 x 1000 Mbps, LC port optical, single mode glass, up to max. 70km)	-	•
SFP992-1ELH	(1 x 1000 Mbps, LC port optical, single mode glass, up to max. 120km)	-	•

*) Note: When used in shipbuilding, installation on a 35 mm DIN rail is not permitted. In ships, the 35 mm DIN rail does not provide adequate support.

Table 8- 135 Permitted ambient conditions

Device: transceiver	(Variant)	Operating temperature	Storage/transport temperature	Relative humidity at 25 °C during operation, maximum	Operating altitude at max. xx °C ambient temperature
SFP991-1	(1 x 100 Mbps, LC port optical, multimode glass, up to max. 3 km)	-40 °C through +85 °C	-40 °C to +85 °C	<= 95% (no condensation)	2000 m at max. 56 °C 3000 m at max. 50 °C
SFP991-1LD	(1 x 100 Mbps, LC port optical, single mode glass, up to max. 26 km)	-40 °C through +85 °C	-40 °C to +85 °C	<= 95% (no condensation)	2000 m at max. 56 °C 3000 m at max. 50 °C
SFP991-1LH+	(1 x 100 Mbps, LC port optical, single mode glass, up to max. 70km)	-40 °C through +85 °C	-40 °C to +85 °C	<= 95% (no condensation)	2000 m at max. 56 °C 3000 m at max. 50 °C
SFP992-1	(1 x 1000 Mbps, LC port optical, multimode glass, up to max. 750m)	-40 °C through +85 °C	-40 °C to +85 °C	<= 95% (no condensation)	2000 m at max. 56 °C 3000 m at max. 50 °C
SFP992-1LD	(1 x 1000 Mbps, LC port optical, single mode glass, up to max. 10km)	-40 °C through +85 °C	-40 °C to +85 °C	<= 95% (no condensation)	2000 m at max. 56 °C 3000 m at max. 50 °C
SFP992-1LH	(1 x 1000 Mbps, LC port optical, single mode glass, up to max. 40km)	-40 °C through +85 °C	-40 °C to +85 °C	<= 95% (no condensation)	2000 m at max. 56 °C 3000 m at max. 50 °C

Device: transceiver	(Variant)	Operating temperature	Storage/transport temperature	Relative humidity at 25 °C during operation, maximum	Operating altitude at max. xx °C ambient temperature
SFP992-LH+	(1 x 1000 Mbps, LC port optical, single mode glass, up to max. 70km)	-40 °C through +85 °C	-40 °C to +85 °C	<= 95% (no condensation)	2000 m at max. 56 °C 3000 m at max. 50 °C
SFP992-1ELH	(1 x 1000 Mbps, LC port optical, single mode glass, up to max. 120km)	-40 °C through +85 °C	-40 °C to +85 °C	<= 95% (no condensation)	2000 m at max. 56 °C 3000 m at max. 50 °C

8.10.2 Connectors and electrical data

Table 8- 136 Connection of end devices or network components

Device: Transceiver	(Variant)	Connection of end devices or network components				
		Max. number	of which:			
			electrical	- optical		
				over FO cable	Single mode	Multi mode
SFP991-1	(1 x 100 Mbps, LC port optical, multimode glass, up to max. 3 km)	2	-	1 x LC port (100 Mbps)	-	•
SFP991-1LD	(1 x 100 Mbps, LC port optical, single mode glass, up to max. 26 km)	2	-	1 x LC port (100 Mbps)	•	-
SFP991-1LH+	(1 x 100 Mbps, LC port optical, single mode glass, up to max. 70km)	2	-	1 x LC port (100 Mbps)	•	-
SFP992-1	(1 x 1000 Mbps, LC port optical, multimode glass, up to max. 750m)	2	-	1 x LC port (1000 Mbps)	-	•
SFP992-1LD	(1 x 1000 Mbps, LC port optical, single mode glass, up to max. 10km)	2	-	1 x LC port (1000 Mbps)	•	-
SFP992-1LH	(1 x 1000 Mbps, LC port optical, single mode glass, up to max. 40km)	2	-	1 x LC port (1000 Mbps)	•	-
SFP992-LH+	(1 x 1000 Mbps, LC port optical, single mode glass, up to max. 70km)	2	-	1 x LC port (1000 Mbps)	•	-
SFP992-1ELH	(1 x 1000 Mbps, LC port optical, single mode glass, up to max. 120km)	2	-	1 x LC port (1000 Mbps)	•	-

8.10 SFP technical specifications

Table 8- 137 Electrical data: Power supply, current consumption and power loss

Device: Transceiver	(Variant)	Effective power loss *)
SFP991-1	(1 x 100 Mbps, LC port optical, multimode glass, up to max. 3 km)	0.36 W
SFP991-1LD	(1 x 100 Mbps, LC port optical, single mode glass, up to max. 26 km)	0.39 W
SFP991-1LH+	(1 x 100 Mbps, LC port optical, single mode glass, up to max. 70km)	0.47 W
SFP992-1	(1 x 1000 Mbps, LC port optical, multimode glass, up to max. 750m)	0.33 W
SFP992-1LD	(1 x 1000 Mbps, LC port optical, single mode glass, up to max. 10km)	0.41 W
SFP992-1LH	(1 x 1000 Mbps, LC port optical, single mode glass, up to max. 40km)	0.45 W
SFP992-LH+	(1 x 1000 Mbps, LC port optical, single mode glass, up to max. 70km)	0.50 W
SFP992-1ELH	(1 x 1000 Mbps, LC port optical, single mode glass, up to max. 120km)	0.63 W

*) Note: SFP values in 25 °C environment.

Note

Fusing of transceivers

The SFP transceivers do not have fuses. The fuse is in the modular device (M).

Note

Signaling contact and media modules

The SFP transceivers do not have a signaling contact. The signaling contact is on the modular device (M).

Table 8- 138 Electrical data: Transmitter output optical and receiver input

Device: Transceiver	(Variant)	Transmitter output optical		Receiver input	
		min. [dBm]	max. [dBm]	Sensitivity min. [dBm]	max. input power [dBm]
SFP991-1	(1 x 100 Mbps, LC port optical, multimode glass, up to max. 3 km)	-19	-14	-32	-3
SFP991-1LD	(1 x 100 Mbps, LC port optical, single mode glass, up to max. 26 km)	-15	-8	-34	-3
SFP991-1LH+	(1 x 100 Mbps, LC port optical, single mode glass, up to max. 70km)	-5	0	-34	-3
SFP992-1	(1 x 1000 Mbps, LC port optical, multimode glass, up to max. 750m)	-9.5	-4	-17	-3
SFP992-1LD	(1 x 1000 Mbps, LC port optical, single mode glass, up to max. 10km)	-9.5	-3	-21	-3
SFP992-1LH	(1 x 1000 Mbps, LC port optical, single mode glass, up to max. 40km)	-6	0	-23	-3
SFP992-LH+	(1 x 1000 Mbps, LC port optical, single mode glass, up to max. 70km)	0	5	-23	-3
SFP992-1ELH	(1 x 1000 Mbps, LC port optical, single mode glass, up to max. 120km)	0	5	-32	-8

8.10.3 Cable lengths

Table 8- 139 Permitted cable lengths (fiber-optic) Fast Ethernet

Device: transceiver	(Variant)	Fiber	FO cable lengths
SFP991-1	(1 x 100 Mbps, LC port optical, multimode glass, up to max. 3 km)	50/125 µm multimode fiber	0-3km (1 dB/km at 1310 nm; 1200 MHz*km; maximum insertion loss 0.5 dB; 9 dB max. permitted FO cable attenuation at 3 dB link power margin)
SFP991-1LD	(1 x 100 Mbps, LC port optical, single mode glass, up to max. 26 km)	9/125 µm single mode fiber	0 -26km (0.5 dB/km at 1300 nm; maximum insertion loss 0.5 dB; 14 dB max. permitted FO cable attenuation at 2 dB link power margin)
SFP991-1LH+	(1 x 100 Mbps, LC port optical, single mode glass, up to max. 70km)	9/125 µm single mode fiber	*) -70 km (0.28 dB/km at 1550 nm; maximum insertion loss 0.5 dB, 26 dB max. permitted FO cable attenuation at 2 dB link power margin, *) minimum cable attenuation 3 dB)

Table 8- 140 Permitted cable lengths (fiber-optic) gigabit

Device: transceiver	(Variant)	Fiber	FO cable lengths
SFP992-1	(1 x 1000 Mbps, LC port optical, multimode glass, up to max. 750m)	62.5/125 µm multi-mode fiber	0-350 m (3.1 dB/km at 850 nm; 1200 MHz*km; maximum insertion loss 0.5 dB; 4.5 dB max. permitted FO cable attenuation at 3 dB link power margin)
		50/125 µm multimode fiber	0-750 m (2.5 dB/km at 850 nm; 1200 MHz*km; maximum insertion loss 0.5 dB; 4.5 dB max. permitted FO cable attenuation at 3 dB link power margin)
SFP992-1LD	(1 x 1000 Mbps, LC port optical, single mode glass, up to max. 10km)	9/125 µm single mode fiber	0 -10 km (0.5 dB/km at 1310 nm; maximum insertion loss 0.5 dB; 6 dB max. permitted FO cable attenuation at 3 dB link power margin)
SFP992-1LH	(1 x 1000 Mbps, LC port optical, single mode glass, up to max. 40km)	9/125 µm single mode fiber	*) -40 km (0.4 dB/km at 1550 nm; maximum insertion loss 0.5 dB, 18 dB max. permitted FO cable attenuation at 2 dB link power margin, *) minimum cable attenuation 3 dB)

Device: transceiver	(Variant)	Fiber	FO cable lengths
SFP992-LH+	(1 x 1000 Mbps, LC port optical, single mode glass, up to max. 70km)	9/125 µm single mode fiber	*) -70 km (0.28 dB/km at 1550 nm; maximum insertion loss 0.5 dB, 21 dB max. permitted FO cable attenuation at 2 dB link power margin, *) minimum cable attenuation 8 dB)
SFP992-1ELH	(1 x 1000 Mbps, LC port optical, single mode glass, up to max. 120km)	9/125 µm single mode fiber	*) -120km (0.225 dB/km at 1550 nm; maximum insertion loss 0.5 dB, 27 dB max. permitted FO cable attenuation at 2 dB link power margin, *) minimum cable attenuation 13 dB)

8.10.4 Other properties

Table 8- 141 MTBF

Device: pluggable transceiver	(Variant)	MTBF ¹⁾
SFP991-1	(1 x 100 Mbps, LC port optical, multimode glass, up to max. 3 km)	> 120 years
SFP991-1LD	(1 x 100 Mbps, LC port optical, single mode glass, up to max. 26 km)	> 120 years
SFP991-1LH+	(1 x 100 Mbps, LC port optical, single mode glass, up to max. 70km)	> 120 years
SFP992-1	(1 x 1000 Mbps, LC port optical, multimode glass, up to max. 750m)	> 120 years
SFP992-1LD	(1 x 1000 Mbps, LC port optical, single mode glass, up to max. 10km)	> 120 years
SFP992-1LH	(1 x 1000 Mbps, LC port optical, single mode glass, up to max. 40km)	> 120 years
SFP992-LH+	(1 x 1000 Mbps, LC port optical, single mode glass, up to max. 70km)	> 120 years
SFP992-1ELH	(1 x 1000 Mbps, LC port optical, single mode glass, up to max. 120km)	> 120 years

¹⁾ These values apply at 40 °C.

Note

The IE Switches X-300 support full wire speed switching complying with IEEE 802.3 on all ports.

The number of packets depends on the packet length according to the IEEE802.3 standard:

Table 8- 142 Full wire speed switching

Number of frames		At a frame length of (in bytes):
at 100 Mbps	at 1000 Mbps	
148810	1488095	64
84459	844595	128
45290	452899	256
23496	234962	512
11973	119732	1024
9615	96154	1280
8127	81274	1518

Note

The following applies to IE Switches X-300:

The number of IE Switches X-300 connected in a line influences the frame propagation time.

When a frame passes through an IE Switch X-300, it is delayed by the Store&Forward function of the IE Switch X-300

- with a 64 byte frame length by approx. 10 microseconds (at 100 Mbps)
- with a 1500 byte frame length by approx. 130 microseconds (at 100 Mbps)

This means that the more IE Switch X-300 devices the frame passes through, the longer the frame delay.

Approvals, certificates, standards

9.1 X-300 product group

9.1.1 X-300 approvals, certificates

Approvals issued

Note

Issued approvals on the type plate of the device

The specified approvals apply only when the corresponding mark is printed on the product. You can check which of the following approvals have been granted for your product by the markings on the type plate.

EC directives

SIMATIC NET products meet the requirements and aims of the following EC directives.

EMC directive (electromagnetic compatibility)

The SIMATIC NET products described in these operating instructions meet the requirements of EC directive 2004/108/EC "Electromagnetic Compatibility" for the following areas of application:

Field of application	Requirements	
	Emission	Immunity to interference
Industry	EN 61000-6-4 : 2007	EN 61000-6-2 : 2005

WARNING

Personal injury and property damage can occur

The installation of expansions that are not approved for SIMATIC NET products or their target systems may violate the requirements and regulations for safety and electromagnetic compatibility.

Only use expansions that are approved for the system.

- **Keep to the installation guidelines**
The devices meet the requirements if you adhere to the installation and safety

instructions contained in this documentation and in the following documentation when installing and operating the devices.

- **You can always find the latest documentation on the Internet**

The current descriptions of the currently available products can always be found on the Internet under the specified entry IDs/Internet pages:

- "Industrial Ethernet / PROFINET Industrial Ethernet" System Manual
- "Industrial Ethernet / PROFINET - Passive network components" System Manual

You will find information on the system manuals in the section "ID = 27069465 (<http://support.automation.siemens.com/WW/view/en/27069465>)", in "Further documentation".

- "EMC Installation Guidelines" configuration manual

ID = 60612658 (<http://support.automation.siemens.com/WW/view/en/60612658>)

- **Working on the device**

To protect the device from electrostatic discharge, personnel must first discharge any electrostatic charge from their body before touching the device.

Note

The test was performed with a device and a connected communications partner that also meets the requirements of the standards listed above.

When operating the device with a communications partner that does not comply with these standards, adherence to the corresponding values cannot be guaranteed.

Machinery directive

The product is a component in compliance with the EC Machinery Directive 2006/42/EEC. According to the machinery directive, we are obliged to point out that the product described is intended solely for installation in a machine.

Before the final product can be put into operation, it must be tested to ensure that it conforms with the directive 2006/42/EEC.

Note

Note for the manufacturers of machines

This product is not a machine in the sense of the EC Machinery Directive. There is therefore no declaration of conformity relating to the EC Machinery Directive 2006/42/EEC for this product.

Note for the manufacturers of machines

This product is not a machine in the sense of the EC Machinery Directive. There is therefore no declaration of conformity relating to the EC Machinery Directive 89/392/EEC for this product.

ATEX (explosion protection directive)

 WARNING
When using SIMATIC NET products in hazardous area zone 2, make absolutely sure that the associated conditions in the following document are adhered to: "SIMATIC NET Product Information Use of subassemblies/modules in a Zone 2 Hazardous Area". You will find this document <ul style="list-style-type: none">• on the data medium that ships with some devices.• on the Internet pages of Siemens Industry Online Support (http://support.automation.siemens.com/WW/view/en). Enter the document identification number C234 as the search term.

SIMATIC NET products meet the requirements of the EC directive:94/9/EC "Equipment and Protective Devices for Use in Potentially Explosive Atmospheres".

ATEX classification:

II 3 G Ex nA IIC T4 Gc

KEMA 07ATEX0145 X

The products meet the requirements of the following standards:

- EN 60079-15: 2010 (electrical apparatus for potentially explosive atmospheres; Type of protection "n")
- EN 60079-0: 2009 (Explosive atmospheres - Part 0: Equipment - General requirements)

IECEX

The SIMATIC NET products meet the requirements of explosion protection according to IECEX.

IECEX classification:

Ex nA IIC T4 Gc

DEK 14.0025X

The products meet the requirements of the following standards:

- IEC 60079-15 : 2010 (Explosive atmospheres - Part 15: Equipment protection by type of protection "n")
- IEC 60079-0 : 2011 (Explosive atmospheres - Part 0: Equipment - General requirements)

FM

The product meets the requirements of the standards:

- Factory Mutual Approval Standard Class Number 3611
- FM Hazardous (Classified) Location Electrical Equipment:
Non Incendive / Class I / Division 2 / Groups A,B,C,D / T4 and
Non Incendive / Class I / Zone 2 / Group IIC / T4

C-Tick

The product meets the requirements of the AS/NZS 2064 standard (Class A).

cULus Approval for Information Technology Equipment

cULus Listed I. T. E.

Underwriters Laboratories Inc. complying with

- UL 60950-1 (Information Technology Equipment)
- CSA C22.2 No. 60950-1-03

Report no. E115352

cULus approval for industrial control equipment

cULus Listed IND. CONT. EQ.

Underwriters Laboratories Inc. complying with

- UL 508
- CSA C22.2 No. 142-M1987

Report no. E85972

cULus Approval Hazardous Location

cULus Listed I. T. E. FOR HAZ. LOC.

Underwriters Laboratories Inc. complying with

- UL 60950-1 (Information Technology Equipment)
- ANSI/ISA 12.12.01-2007
- CSA C22.2 No. 213-M1987

Approved for use in

Cl. 1, Div. 2, GP A, B, C, D T4

Cl. 1, Zone 2, GP IIC T4

Report no. E240480

9.1.2 X-300 type plate

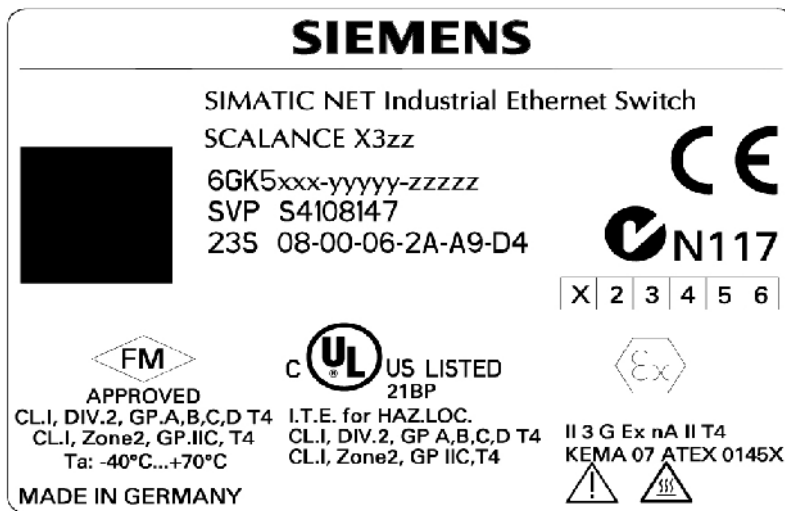

Image 9-1 X-300 specimen type plate

9.1.3 SCALANCE X-300 declaration of conformity

You will find the EC Declaration of Conformity for these products on the Internet at the following address:

SCALANCE X-300 declaration of conformity
<https://support.industry.siemens.com/cs/ww/en/ps/15296/cert>

1. Click on the entry "SCALANCE X-300 managed" in the navigation panel at the top edge of the window and from the drop-down list that opens, select the entry for your product group.
2. Select the entry "Certificate" from the "Entry type" drop-down list.

Result: A list of the available certificates is displayed.

9.1.4 X-300 FDA and IEC approvals

The following devices meet the FDA and IEC requirements listed below:

Type	Fulfills FDA and IEC requirements
X304-2FE	CLASS 1 LED Product
X306-1LD FE	CLASS 1 LASER Product
X307-3	CLASS 1 LASER Product
X307-3LD	CLASS 1 LASER Product
X308-2	CLASS 1 LASER Product
X308-2LD	CLASS 1 LASER Product

9.1 X-300 product group

Type	Fulfills FDA and IEC requirements
X308-2LH	CLASS 1 LASER Product
X308-2LH+	CLASS 1 LASER Product
X310	-
X310FE	-
X320-1FE	CLASS 1 LED Product
X320-3LD FE	CLASS 1 LASER Product



Image 9-2 FDA and IEC approvals

9.1.5 Overview of the X-300 approvals

Table 9- 1 Overview of the approvals

Type	c-UL-us	c-UL-us for hazardous locations ¹	FM ¹	C-TICK	CE	ATEX95 Zone 2 ¹	E1
X304-2FE	•	•	•	•	•	•	-
X306-1LD FE	•	•	•	•	•	•	-
X307-3	•	•	•	•	•	•	-
X307-3LD	•	•	•	•	•	•	-
X308-2	•	•	•	•	•	•	-
X308-2LD	•	•	•	•	•	•	-
X308-2LH	•	•	•	•	•	•	-
X308-2LH+	•	•	•	•	•	•	-
X310	•	•	•	•	•	•	-
X310FE	•	•	•	•	•	•	-
X320-1FE	•	•	•	•	•	•	-
X320-3LD FE	•	•	•	•	•	•	-

¹For temperature information "T.." or the maximum ambient temperature "Ta:..", refer to the type plate.

Note

Shipbuilding approval

No applications for shipbuilding approvals will be made for the SCALANCE X-300.

9.1.6 X-300 mechanical stability (in operation)

Type	IEC 60068-2-6 vibration	IEC 60068-2-27 shock
	5 – 9 Hz: 3.5 mm 9 – 150 Hz: 1 g 1 octave/min, 20 sweeps	15 g, 11 ms duration 6 shocks per axis
X304-2FE	•	•
X306-1LD FE	•	•
X307-3	•	•
X307-3LD	•	•
X308-2	•	•
X308-2LD	•	•
X308-2LH	•	•
X308-2LH+	•	•
X310	•	•
X310FE	•	•
X320-1FE	•	•
X320-3LD FE	•	•

9.2 Product group X-300M

9.2.1 X-300M approvals, certificates

Approvals issued

Note

Issued approvals on the type plate of the device

The specified approvals apply only when the corresponding mark is printed on the product. You can check which of the following approvals have been granted for your product by the markings on the type plate.

EC directives

SIMATIC NET products meet the requirements and aims of the following EC directives.

EMC directive (electromagnetic compatibility)

The SIMATIC NET products described in these operating instructions meet the requirements of EC directive 2004/108/EC "Electromagnetic Compatibility" for the following areas of application:

Field of application	Requirements	
	Emission	Immunity to interference
Industry	EN 61000-6-4 : 2007	EN 61000-6-2 : 2005

<p>⚠ WARNING</p> <p>Personal injury and property damage can occur</p> <p>The installation of expansions that are not approved for SIMATIC NET products or their target systems may violate the requirements and regulations for safety and electromagnetic compatibility.</p> <p>Only use expansions that are approved for the system.</p>
--

- **Keep to the installation guidelines**
The devices meet the requirements if you adhere to the installation and safety instructions contained in this documentation and in the following documentation when installing and operating the devices.
- **You can always find the latest documentation on the Internet**
The current descriptions of the currently available products can always be found on the Internet under the specified entry IDs/Internet pages:
 - "Industrial Ethernet / PROFINET Industrial Ethernet" System Manual
 - "Industrial Ethernet / PROFINET - Passive network components" System Manual

You will find information on the system manuals in the section "ID = 27069465 (<http://support.automation.siemens.com/WW/view/en/27069465>)", in "Further documentation".

 - "EMC Installation Guidelines" configuration manual
ID = 60612658 (<http://support.automation.siemens.com/WW/view/en/60612658>)
- **Working on the device**
To protect the device from electrostatic discharge, personnel must first discharge any electrostatic charge from their body before touching the device.

Note

The test was performed with a device and a connected communications partner that also meets the requirements of the standards listed above.

When operating the device with a communications partner that does not comply with these standards, adherence to the corresponding values cannot be guaranteed.

Machinery directive

The product is a component in compliance with the EC Machinery Directive 2006/42/EEC. According to the machinery directive, we are obliged to point out that the product described is intended solely for installation in a machine.

Before the final product can be put into operation, it must be tested to ensure that it conforms with the directive 2006/42/EEC.

Note

Note for the manufacturers of machines

This product is not a machine in the sense of the EC Machinery Directive. There is therefore no declaration of conformity relating to the EC Machinery Directive 2006/42/EEC for this product.

Note for the manufacturers of machines

This product is not a machine in the sense of the EC Machinery Directive. There is therefore no declaration of conformity relating to the EC Machinery Directive 89/392/EEC for this product.

ATEX (explosion protection directive)

 WARNING
When using SIMATIC NET products in hazardous area zone 2, make absolutely sure that the associated conditions in the following document are adhered to: "SIMATIC NET Product Information Use of subassemblies/modules in a Zone 2 Hazardous Area". You will find this document <ul style="list-style-type: none">• on the data medium that ships with some devices.• on the Internet pages of Siemens Industry Online Support (http://support.automation.siemens.com/WWW/view/en). Enter the document identification number C234 as the search term.

SIMATIC NET products meet the requirements of the EC directive:94/9/EC "Equipment and Protective Devices for Use in Potentially Explosive Atmospheres".

ATEX classification:

II 3 G Ex nA IIC T4 Gc

KEMA 07ATEX0145 X

The products meet the requirements of the following standards:

- EN 60079-15: 2010 (electrical apparatus for potentially explosive atmospheres; Type of protection "n")
- EN 60079-0: 2009 (Explosive atmospheres - Part 0: Equipment - General requirements)

IECEX

The SIMATIC NET products meet the requirements of explosion protection according to IECEX.

IECEX classification:

Ex nA IIC T4 Gc

DEK 14.0025X

The products meet the requirements of the following standards:

- IEC 60079-15 : 2010 (Explosive atmospheres - Part 15: Equipment protection by type of protection "n")
- IEC 60079-0 : 2011 (Explosive atmospheres - Part 0: Equipment - General requirements)

FM

The product meets the requirements of the standards:

- Factory Mutual Approval Standard Class Number 3611
- FM Hazardous (Classified) Location Electrical Equipment:
Non Incendive / Class I / Division 2 / Groups A,B,C,D / T4 and
Non Incendive / Class I / Zone 2 / Group IIC / T4

C-Tick

The product meets the requirements of the AS/NZS 2064 standard (Class A).

cULus Approval for Information Technology Equipment

cULus Listed I. T. E.

Underwriters Laboratories Inc. complying with

- UL 60950-1 (Information Technology Equipment)
- CSA C22.2 No. 60950-1-03

Report no. E115352

cULus Approval Hazardous Location

cULus Listed I. T. E. FOR HAZ. LOC.

Underwriters Laboratories Inc. complying with

- UL 60950-1 (Information Technology Equipment)
- ANSI/ISA 12.12.01-2007
- CSA C22.2 No. 213-M1987

Approved for use in

Cl. 1, Div. 2, GP A, B, C, D T4

Cl. 1, Zone 2, GP IIC T4

Report no. E240480

Railway approval

The TS variant of the device meets the requirements of the Railway standard EN 50155:2007 "Railway Applications - Electronic equipment used on rolling stock".

9.2.2 X-300M type plate

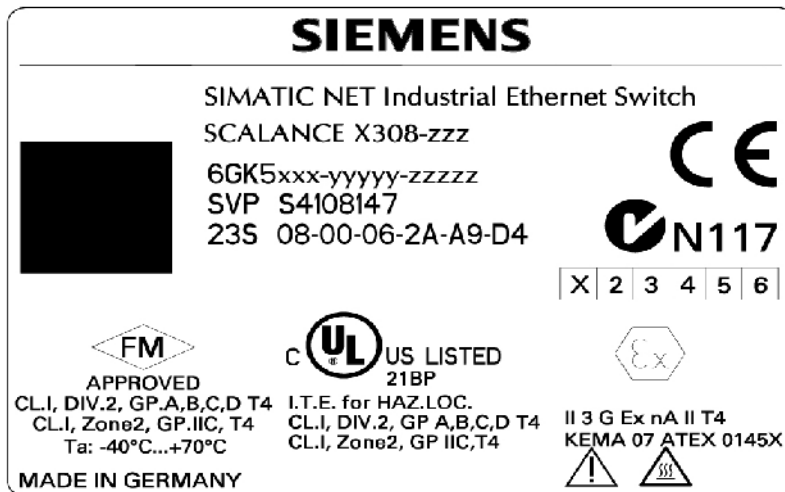

Image 9-3 Specimen X-300M type plate

9.2.3 SCALANCE X-300 declaration of conformity

You will find the EC Declaration of Conformity for these products on the Internet at the following address:

SCALANCE X-300 declaration of conformity

(<https://support.industry.siemens.com/cs/ww/en/ps/15296/cert>)

1. Click on the entry "SCALANCE X-300 managed" in the navigation panel at the top edge of the window and from the drop-down list that opens, select the entry for your product group.
2. Select the entry "Certificate" from the "Entry type" drop-down list.

Result: A list of the available certificates is displayed.

9.2.4 X-300M FDA and IEC approvals

The following devices meet the FDA and IEC requirements listed below:

Product line	Product group	Device: SCALANCE	(Variant)	Fulfills FDA and IEC requirements
X-300	X-300M	X308-2M	-	-
X-300	X-300M	X308-2M TS	-	-

Note: In the modular devices (M), the marking is provided by the MM900 media modules and the SFP transceivers.



Image 9-4 FDA and IEC approvals

9.2.5 Overview of X-300M approvals

Table 9- 2 Overview of the approvals

Device: SCALANCE	(Variant)	c-UL-us	c-UL-us for hazard- ous loca- tions ¹	FM ¹	C-TICK	CE	ATEX95 Zone 2 ¹	E1
X308-2M	(-)	•	•	•	•	•	•	-
X308-2M TS	(-)	•	•	•	•	•	•	-

¹For temperature information "T.." or the maximum ambient temperature "Ta:..", refer to the type plate.

Note

Shipbuilding approval

No applications for shipbuilding approvals will be made for the SCALANCE X-300M.

9.2.6 X-300M mechanical stability (in operation)

Device: SCALANCE	(Variant)	IEC 60068-2-6 vibration	IEC 60068-2-27 shock
		5 – 9 Hz: 3.5 mm 9 – 150 Hz: 1 g 1 octave/min, 20 sweeps	15 g, 11 ms duration 6 shocks per axis
X308-2M	(-)	•	•
X308-2M TS	(-)	•	•

9.3 Product group XR-300M

9.3.1 XR-300M approvals, certificates

Approvals issued

Note

Issued approvals on the type plate of the device

The specified approvals apply only when the corresponding mark is printed on the product. You can check which of the following approvals have been granted for your product by the markings on the type plate.

EC directives

SIMATIC NET products meet the requirements and aims of the following EC directives.

EMC directive (electromagnetic compatibility)

The SIMATIC NET products described in these operating instructions meet the requirements of EC directive 2004/108/EC "Electromagnetic Compatibility" for the following areas of application:

Field of application	Requirements	
	Emission	Immunity to interference
Industry	EN 61000-6-4 : 2007	EN 61000-6-2 : 2005

Field of application	Requirements	
	Emission	Immunity to interference

<p>⚠ WARNING</p> <p>Personal injury and property damage can occur</p> <p>The installation of expansions that are not approved for SIMATIC NET products or their target systems may violate the requirements and regulations for safety and electromagnetic compatibility.</p> <p>Only use expansions that are approved for the system.</p>
--

- **Keep to the installation guidelines**
The devices meet the requirements if you adhere to the installation and safety instructions contained in this documentation and in the following documentation when installing and operating the devices.
- **You can always find the latest documentation on the Internet**
The current descriptions of the currently available products can always be found on the Internet under the specified entry IDs/Internet pages:
 - "Industrial Ethernet / PROFINET Industrial Ethernet" System Manual
 - "Industrial Ethernet / PROFINET - Passive network components" System Manual

You will find information on the system manuals in the section "ID = 27069465 (<http://support.automation.siemens.com/WW/view/en/27069465>)", in "Further documentation".

 - "EMC Installation Guidelines" configuration manual
ID = 60612658 (<http://support.automation.siemens.com/WW/view/en/60612658>)
- **Working on the device**
To protect the device from electrostatic discharge, personnel must first discharge any electrostatic charge from their body before touching the device.

Note

The test was performed with a device and a connected communications partner that also meets the requirements of the standards listed above.

When operating the device with a communications partner that does not comply with these standards, adherence to the corresponding values cannot be guaranteed.

Machinery directive

The product is a component in compliance with the EC Machinery Directive 2006/42/EEC. According to the machinery directive, we are obliged to point out that the product described is intended solely for installation in a machine.

Before the final product can be put into operation, it must be tested to ensure that it conforms with the directive 2006/42/EEC.

Note**Note for the manufacturers of machines**

This product is not a machine in the sense of the EC Machinery Directive. There is therefore no declaration of conformity relating to the EC Machinery Directive 2006/42/EEC for this product.

Note for the manufacturers of machines

This product is not a machine in the sense of the EC Machinery Directive. There is therefore no declaration of conformity relating to the EC Machinery Directive 89/392/EEC for this product.

ATEX (explosion protection directive)

 WARNING
When using SIMATIC NET products in hazardous area zone 2, make absolutely sure that the associated conditions in the following document are adhered to: "SIMATIC NET Product Information Use of subassemblies/modules in a Zone 2 Hazardous Area". You will find this document <ul style="list-style-type: none">• on the data medium that ships with some devices.• on the Internet pages of Siemens Industry Online Support (http://support.automation.siemens.com/WW/view/en). Enter the document identification number C234 as the search term.

SIMATIC NET products meet the requirements of the EC directive:94/9/EC "Equipment and Protective Devices for Use in Potentially Explosive Atmospheres".

ATEX classification:

II 3 G Ex nA IIC T4 Gc

KEMA 07ATEX0145 X

The products meet the requirements of the following standards:

- EN 60079-15: 2010 (electrical apparatus for potentially explosive atmospheres; Type of protection "n")
- EN 60079-0: 2009 (Explosive atmospheres - Part 0: Equipment - General requirements)

Note

Only variants with 24 VDC power supply meet the requirements of this approval.

IECEX

The SIMATIC NET products meet the requirements of explosion protection according to IECEX.

IECEX classification:

Ex nA IIC T4 Gc

DEK 14.0025X

The products meet the requirements of the following standards:

- IEC 60079-15 : 2010 (Explosive atmospheres - Part 15: Equipment protection by type of protection "n")
- IEC 60079-0 : 2011 (Explosive atmospheres - Part 0: Equipment - General requirements)

Note

Only variants with 24 VDC power supply meet the requirements of this approval.

FM

The product meets the requirements of the standards:

- Factory Mutual Approval Standard Class Number 3611
- FM Hazardous (Classified) Location Electrical Equipment:
Non Incendive / Class I / Division 2 / Groups A,B,C,D / T4 and
Non Incendive / Class I / Zone 2 / Group IIC / T4

Note

Only variants with 24 VDC power supply meet the requirements of this approval.

C-Tick

The product meets the requirements of the AS/NZS 2064 standard (Class A).

cULus Approval for Information Technology Equipment

cULus Listed I. T. E.

Underwriters Laboratories Inc. complying with

- UL 60950-1 (Information Technology Equipment)
- CSA C22.2 No. 60950-1-03

Report no. E115352

Note

Only variants with 24 VDC power supply meet the requirements of this approval.

cULus approval for industrial control equipment

cULus Listed IND. CONT. EQ.

Underwriters Laboratories Inc. complying with

- UL 508
- CSA C22.2 No. 142-M1987

Report no. E85972

Note

Only variants with 100 to 240 VAC power supply meet the requirements of this approval.

cULus Approval Hazardous Location

cULus Listed I. T. E. FOR HAZ. LOC.

Underwriters Laboratories Inc. complying with

- UL 60950-1 (Information Technology Equipment)
- ANSI/ISA 12.12.01-2007
- CSA C22.2 No. 213-M1987

Approved for use in
Cl. 1, Div. 2, GP A, B, C, D T4
Cl. 1, Zone 2, GP IIC T4

Report no. E240480

Note

Only variants with 24 VDC power supply meet the requirements of this approval.

Railway approval

The TS variant of the device meets the requirements of the Railway standard EN 50155:2007 "Railway Applications - Electronic equipment used on rolling stock".

Note

When used on railway stock, a stabilized power supply must be used to comply with EN50155.

9.3.2 XR-300M type plate

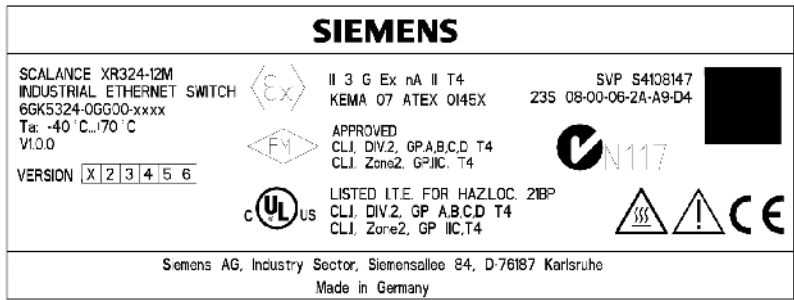

Image 9-5 Specimen XR-300M type plate

9.3.3 SCALANCE X-300 declaration of conformity

You will find the EC Declaration of Conformity for these products on the Internet at the following address:

SCALANCE X-300 declaration of conformity
<https://support.industry.siemens.com/cs/ww/en/ps/15296/cert>

1. Click on the entry "SCALANCE X-300 managed" in the navigation panel at the top edge of the window and from the drop-down list that opens, select the entry for your product group.
2. Select the entry "Certificate" from the "Entry type" drop-down list.

Result: A list of the available certificates is displayed.

9.3.4 XR-300M FDA and IEC approvals

The following devices meet the FDA and IEC requirements listed below:

Product line	Product group	Device: SCALANCE	Variant	Fulfills FDA and IEC requirements
X-300	XR-300M	XR324-12M	2 x 24 VDC Data cable outlet on front	-
			1 x 100 to 240 VAC Data cable outlet on front	-
			2 x 24 VDC Data cable outlet at rear	-
			1 x 100 to 240 VAC Data cable outlet at rear	-

Note: In the modular devices (M), the marking is provided by the MM900 media modules and the SFP transceivers.



Image 9-6 FDA and IEC approvals

9.3.5 Overview of XR-300M approvals

Note

The 24 V DC variants do not have an E1 approval.

The 100 to 240 V AC variants have C-Tick and CE approvals but are only UL508 listed. They do not have UL hazloc, FM or ATEX approvals.

Table 9- 3 Overview of the approvals

Device	Variant	c-UL-us Inf. Tech. Eq.	c-UL-us for Hazard- ous Loca- tions ¹⁾	c-UL-us Ind. Cont. Eq.	FM ¹⁾	C-TICK	CE	ATEX95 Zone 2 ¹⁾
XR324- 12M	2 x 24 VDC, Data cable outlet on front	•	•	-	•	•	•	•
	1 x 100 to 240 VAC, Data cable outlet on front	-	-	•	-	•	•	-
	2 x 24 VDC Data cable outlet at rear	•	•	-	•	•	•	•
	1 x 100 to 240 VAC, data cable outlet at rear	-	-	•	-	•	•	-

¹⁾ For temperature information "T.." or the maximum ambient temperature "Ta:..", refer to the type plate.

9.3.6 XR-300M mechanical stability (in operation)

Device: SCALANCE	(Variant)	IEC 60068-2-6 vibration	IEC 60068-2-27 shock	IEC 60068-2-6 vibration *)
		10 – 58 Hz: 0.15 mm 58 – 500 Hz: 1 g 1 octave/min, 10 cycles	15 g, 11 ms duration 6 shocks per axis	5 – 8.51 Hz: 7 mm 8.51 – 500 Hz: 1 g 1 octave/min, 10 cycles
XR324-12M	(2 x DC data cable outlet on front)	•	•	•
XR324-12M	(1 x 100...240 VAC, data cable outlet on front)	•	•	•
XR324-12M	(2 x 24 VDC data cable outlet at rear)	•	•	•
XR324-12M	(1 x 100 to 240 VAC, data cable outlet at rear)	•	•	•

*) Note: When rack mounted with 4 securing points

9.4 X-300EEC product group

9.4.1 X-300EEC approvals and certificates

Approvals issued

Note

Issued approvals on the type plate of the device

The specified approvals apply only when the corresponding mark is printed on the product. You can check which of the following approvals have been granted for your product by the markings on the type plate.

The term "the product" as used below includes all device variants of the SCALANCE X-300EEC unless specific variants are expressly named for an approval.

EC directives

SIMATIC NET products meet the requirements and aims of the following EC directives.

Low voltage equipment directive

Devices supplied with 100 to 240 VAC meet the requirements of the directive 2006/95/EC "Electrical Equipment Designed for Use within Certain Voltage Limits" (Low Voltage Equipment Directive). Conformity attested by compliance with the standard EN 60950-1:2010.

EMC directive (electromagnetic compatibility)

The SIMATIC NET products described in these operating instructions meet the requirements of EC directive 2004/108/EC "Electromagnetic Compatibility" for the following areas of application:

Field of application	Requirements	
	Emission	Immunity to interference
Industry	EN 61000-6-4 : 2007	EN 61000-6-2 : 2005

Field of application	Requirements	
	Emission	Immunity to interference

<p>⚠ WARNING</p> <p>Personal injury and property damage can occur</p> <p>The installation of expansions that are not approved for SIMATIC NET products or their target systems may violate the requirements and regulations for safety and electromagnetic compatibility.</p> <p>Only use expansions that are approved for the system.</p>
--

- **Keep to the installation guidelines**
 The devices meet the requirements if you adhere to the installation and safety instructions contained in this documentation and in the following documentation when installing and operating the devices.
- **You can always find the latest documentation on the Internet**
 The current descriptions of the currently available products can always be found on the Internet under the specified entry IDs/Internet pages:

 - "Industrial Ethernet / PROFINET Industrial Ethernet" System Manual
 - "Industrial Ethernet / PROFINET - Passive network components" System Manual

You will find information on the system manuals in the section "ID = 27069465 (<http://support.automation.siemens.com/WW/view/en/27069465>)", in "Further documentation".

 - "EMC Installation Guidelines" configuration manual
 ID = 60612658 (<http://support.automation.siemens.com/WW/view/en/60612658>)
- **Working on the device**
 To protect the device from electrostatic discharge, personnel must first discharge any electrostatic charge from their body before touching the device.

Note

The test was performed with a device and a connected communications partner that also meets the requirements of the standards listed above.

When operating the device with a communications partner that does not comply with these standards, adherence to the corresponding values cannot be guaranteed.

Machinery directive

The product is a component in compliance with the EC Machinery Directive 2006/42/EEC. According to the machinery directive, we are obliged to point out that the product described is intended solely for installation in a machine.

Before the final product can be put into operation, it must be tested to ensure that it conforms with the directive 2006/42/EEC.

Note**Note for the manufacturers of machines**

This product is not a machine in the sense of the EC Machinery Directive. There is therefore no declaration of conformity relating to the EC Machinery Directive 2006/42/EEC for this product.

ATEX (explosion protection directive)

 WARNING
When using SIMATIC NET products in hazardous area zone 2, make absolutely sure that the associated conditions in the following document are adhered to: "SIMATIC NET Product Information Use of subassemblies/modules in a Zone 2 Hazardous Area". You will find this document <ul style="list-style-type: none">• on the data medium that ships with some devices.• on the Internet pages of Siemens Industry Online Support (http://support.automation.siemens.com/WW/view/en). Enter the document identification number C234 as the search term.

SIMATIC NET products meet the requirements of the EC directive:94/9/EC "Equipment and Protective Devices for Use in Potentially Explosive Atmospheres".

ATEX classification:

II 3 G Ex nA IIC T4 Gc

KEMA 07ATEX0145 X

The products meet the requirements of the following standards:

- EN 60079-15: 2010 (electrical apparatus for potentially explosive atmospheres; Type of protection "n")
- EN 60079-0: 2009 (Explosive atmospheres - Part 0: Equipment - General requirements)

Note

Only variants with 24 VDC power supply meet the requirements of this approval.

IECEX

The SIMATIC NET products meet the requirements of explosion protection according to IECEX.

IECEX classification:

Ex nA IIC T4 Gc

DEK 14.0025X

The products meet the requirements of the following standards:

- IEC 60079-15 : 2010 (Explosive atmospheres - Part 15: Equipment protection by type of protection "n")
- IEC 60079-0 : 2011 (Explosive atmospheres - Part 0: Equipment - General requirements)

Note

Only variants with 24 VDC power supply meet the requirements of this approval.

IEC 61850-3 (EN55022 / CISPR22 CLASS A)

The product meets the requirements of the standard IEC 61850-3 (EN55022 / CISPR22 CLASS A).

IEEE 1613

The product meets the requirements of the standard IEEE 1613 CLASS 1 (electrical ports) or IEEE 1613 CLASS 2 (optical ports).

FM

The product meets the requirements of the standards:

- Factory Mutual Approval Standard Class Number 3611
- FM Hazardous (Classified) Location Electrical Equipment:
Non Incendive / Class I / Division 2 / Groups A,B,C,D / T4 and
Non Incendive / Class I / Zone 2 / Group IIC / T4

Note

Only variants with 24 VDC power supply meet the requirements of this approval.

C-Tick

The product meets the requirements of the AS/NZS 2064 standard (Class A).

cULus approval for industrial control equipment

cULus Listed IND. CONT. EQ.

Underwriters Laboratories Inc. complying with

- UL 508
- CSA C22.2 No. 142-M1987

Report no. E85972

Note

Only variants with 100 to 240 VAC power supply meet the requirements of this approval.

cULus Approval Hazardous Location

cULus Listed I. T. E. FOR HAZ. LOC.

Underwriters Laboratories Inc. complying with

- UL 60950-1 (Information Technology Equipment)
- ANSI/ISA 12.12.01-2007
- CSA C22.2 No. 213-M1987

Approved for use in

Cl. 1, Div. 2, GP A, B, C, D T4

Cl. 1, Zone 2, GP IIC T4

Report no. E240480

Note

Only variants with 24 VDC power supply meet the requirements of this approval.

9.4.2 SCALANCE X-300 declaration of conformity

You will find the EC Declaration of Conformity for these products on the Internet at the following address:

SCALANCE X-300 declaration of conformity

(<https://support.industry.siemens.com/cs/ww/en/ps/15296/cert>)

1. Click on the entry "SCALANCE X-300 managed" in the navigation panel at the top edge of the window and from the drop-down list that opens, select the entry for your product group.
2. Select the entry "Certificate" from the "Entry type" drop-down list.

Result: A list of the available certificates is displayed.

9.4.3 Overview of the approvals for the X-300EEC

Table 9- 4 Overview of the approvals

Device	Variant	c-UL-us Inf. Tech. Eq.	c-UL-us for Hazard- ous Loca- tions ¹⁾	c-UL-us Ind. Cont. Eq.	FM ¹⁾	C-TICK	CE	ATEX95 Zone 2 ¹⁾
X302- 7EEC	24 to 48 VDC	•	•	-	•	•	•	•
X302- 2EEC	100...240 VAC / 60...250 VDC	-	-	•	-	•	•	-

¹⁾ For temperature information "T.." or the maximum ambient temperature "Ta..", refer to the type plate.

9.4.4 X-300EEC mechanical stability (in operation)

All variants of the IE Switch SCALANCE X-300EEC meet the following requirements for mechanical stability:

- IEC 60068-2-6 (vibration)
 - 5 – 9 Hz: 3.5 mm
 - 9 – 150 Hz: 1 g
 - 1 octave/min, 20 sweeps
- IEC 60068-2-27 (shock)
 - 15 g, 11 ms duration
 - 6 shocks per axis

For further details, refer to the technical specifications.

9.5 XR-300M EEC product group

9.5.1 XR-300M EEC approvals, certificates

Approvals issued

Note

Issued approvals on the type plate of the device

The specified approvals apply only when the corresponding mark is printed on the product. You can check which of the following approvals have been granted for your product by the markings on the type plate.

EC directives

SIMATIC NET products meet the requirements and aims of the following EC directives.

Low voltage equipment directive

Devices supplied with 100 to 240 VAC meet the requirements of the directive 2006/95/EC "Electrical Equipment Designed for Use within Certain Voltage Limits" (Low Voltage Equipment Directive). Conformity attested by compliance with the standard EN 60950-1:2010.

EMC directive (electromagnetic compatibility)

The SIMATIC NET products described in these operating instructions meet the requirements of EC directive 2004/108/EC "Electromagnetic Compatibility" for the following areas of application:

Field of application	Requirements	
	Emission	Immunity to interference
Industry	EN 61000-6-4 : 2007	EN 61000-6-2 : 2005

WARNING

Personal injury and property damage can occur

The installation of expansions that are not approved for SIMATIC NET products or their target systems may violate the requirements and regulations for safety and electromagnetic compatibility.

Only use expansions that are approved for the system.

- **Keep to the installation guidelines**
The devices meet the requirements if you adhere to the installation and safety instructions contained in this documentation and in the following documentation when installing and operating the devices.
- **You can always find the latest documentation on the Internet**
The current descriptions of the currently available products can always be found on the Internet under the specified entry IDs/Internet pages:
 - "Industrial Ethernet / PROFINET Industrial Ethernet" System Manual
 - "Industrial Ethernet / PROFINET - Passive network components" System Manual
You will find information on the system manuals in the section "ID = 27069465 (<http://support.automation.siemens.com/WW/view/en/27069465>)", in "Further documentation".
 - "EMC Installation Guidelines" configuration manual
ID = 60612658 (<http://support.automation.siemens.com/WW/view/en/60612658>)
- **Working on the device**
To protect the device from electrostatic discharge, personnel must first discharge any electrostatic charge from their body before touching the device.

Note

The test was performed with a device and a connected communications partner that also meets the requirements of the standards listed above.

When operating the device with a communications partner that does not comply with these standards, adherence to the corresponding values cannot be guaranteed.

Machinery directive

The product is a component in compliance with the EC Machinery Directive 2006/42/EEC. According to the machinery directive, we are obliged to point out that the product described is intended solely for installation in a machine.

Before the final product can be put into operation, it must be tested to ensure that it conforms with the directive 2006/42/EEC.

Note

Note for the manufacturers of machines

This product is not a machine in the sense of the EC Machinery Directive. There is therefore no declaration of conformity relating to the EC Machinery Directive 2006/42/EEC for this product.

Note for the manufacturers of machines

This product is not a machine in the sense of the EC Machinery Directive. There is therefore no declaration of conformity relating to the EC Machinery Directive 89/392/EEC for this product.

ATEX (explosion protection directive)

 WARNING
When using SIMATIC NET products in hazardous area zone 2, make absolutely sure that the associated conditions in the following document are adhered to: "SIMATIC NET Product Information Use of subassemblies/modules in a Zone 2 Hazardous Area". You will find this document <ul style="list-style-type: none">• on the data medium that ships with some devices.• on the Internet pages of Siemens Industry Online Support (http://support.automation.siemens.com/WW/view/en). Enter the document identification number C234 as the search term.

SIMATIC NET products meet the requirements of the EC directive:94/9/EC "Equipment and Protective Devices for Use in Potentially Explosive Atmospheres".

ATEX classification:

II 3 G Ex nA IIC T4 Gc

KEMA 07ATEX0145 X

The products meet the requirements of the following standards:

- EN 60079-15: 2010 (electrical apparatus for potentially explosive atmospheres; Type of protection "n")
- EN 60079-0: 2009 (Explosive atmospheres - Part 0: Equipment - General requirements)

Note

Only variants with 24 VDC power supply meet the requirements of this approval.

IECEX

The SIMATIC NET products meet the requirements of explosion protection according to IECEX.

IECEX classification:

Ex nA IIC T4 Gc

DEK 14.0025X

The products meet the requirements of the following standards:

- IEC 60079-15 : 2010 (Explosive atmospheres - Part 15: Equipment protection by type of protection "n")
- IEC 60079-0 : 2011 (Explosive atmospheres - Part 0: Equipment - General requirements)

Note

Only variants with 24 VDC power supply meet the requirements of this approval.

IEC 61850-3 (EN55022 / CISPR22 CLASS A)

The product meets the requirements of the standard IEC 61850-3 (EN55022 / CISPR22 CLASS A).

IEEE 1613

The product meets the requirements of the standard IEEE 1613 CLASS 1 (electrical ports) or IEEE 1613 CLASS 2 (optical ports).

FM

The product meets the requirements of the standards:

- Factory Mutual Approval Standard Class Number 3611
- FM Hazardous (Classified) Location Electrical Equipment:
Non Incendive / Class I / Division 2 / Groups A,B,C,D / T4 and
Non Incendive / Class I / Zone 2 / Group IIC / T4

Note

Only variants with 24 VDC power supply meet the requirements of this approval.

C-Tick

The product meets the requirements of the AS/NZS 2064 standard (Class A).

cULus Approval for Information Technology Equipment

cULus Listed I. T. E.

Underwriters Laboratories Inc. complying with

- UL 60950-1 (Information Technology Equipment)
- CSA C22.2 No. 60950-1-03

Report no. E115352

Note

Only variants with 24 VDC power supply meet the requirements of this approval.

cULus approval for industrial control equipment

cULus Listed IND. CONT. EQ.

Underwriters Laboratories Inc. complying with

- UL 508
- CSA C22.2 No. 142-M1987

Report no. E85972

Note

Only variants with 100 to 240 VAC power supply meet the requirements of this approval.

cULus Approval Hazardous Location

cULus Listed I. T. E. FOR HAZ. LOC.

Underwriters Laboratories Inc. complying with

- UL 60950-1 (Information Technology Equipment)
- ANSI/ISA 12.12.01-2007
- CSA C22.2 No. 213-M1987

Approved for use in

Cl. 1, Div. 2, GP A, B, C, D T4

Cl. 1, Zone 2, GP IIC T4

Report no. E240480

Note

Only variants with 24 VDC power supply meet the requirements of this approval.

9.5.2 SCALANCE X-300 declaration of conformity

You will find the EC Declaration of Conformity for these products on the Internet at the following address:

SCALANCE X-300 declaration of conformity

(<https://support.industry.siemens.com/cs/ww/en/ps/15296/cert>)

1. Click on the entry "SCALANCE X-300 managed" in the navigation panel at the top edge of the window and from the drop-down list that opens, select the entry for your product group.
2. Select the entry "Certificate" from the "Entry type" drop-down list.

Result: A list of the available certificates is displayed.

9.5.3 Overview of XR-300M EEC approvals

Note

The 24 to 48 V variants do not have an E1 approval.

The 100 to 240 V variants have C-Tick and CE approvals, are only UL508 listed, have no UL hazloc, FM or ATEX.

Table 9- 5 Overview of the approvals

Device	Variant	c-UL-us Inf. Tech. Eq.	c-UL-us for Hazardous Locations ¹⁾	c-UL-us Ind. Cont. Eq.	FM ¹⁾	C-TICK	CE	ATEX95 Zone 2 ¹⁾
XR324-4M EEC	1 x 24 to 48 VDC, data cable outlet on front	•	•	-	•	•	•	•
	2 x 24 to 48 VDC, data cable outlet on front	•	•	-	•	•	•	•
	1 x 100 to 240 VAC / 60 to 250 VDC, data cable outlet on front	-	-	•	-	•	•	-
	2 x 100 to 240 VAC / 60 to 250 VDC, data cable outlet on front	-	-	•	-	•	•	-
	1 x 24 to 48 VDC, data cable outlet at rear	•	•	-	•	•	•	•
	2 x 24 to 48 VDC, Data cable outlet at rear	•	•	-	•	•	•	•
	1 x 100 to 240 VAC / 60 to 250 VDC, data cable outlet at rear	-	-	•	-	•	•	-
	2 x 100 to 240 VAC / 60 to 250 VDC, data cable outlet at rear	-	-	•	-	•	•	-

¹⁾ For temperature information "T.." or the maximum ambient temperature "Ta:..", refer to the type plate.

9.5.4 XR-300M EEC mechanical stability (in operation)

The devices of the SCALANCE XR-300M EEC product group meet the following standards (prerequisite: rack mounted with 4 securing points):

- **IEC 60068-2-6**
(vibrations during transportation and operation)
Test parameters:
5 – 9 Hz: 3.5 mm

9 – 150 Hz: 1 g
1 octave/min, 20 sweeps

- **IEC 60068-2-27**
(shocks during operation)
Test parameters:
15 g , 11 ms duration
6 shocks per axis
- **IEC 60068-2-6**
(vibrations during transportation)
Test parameters:
10 – 58 Hz: 0.075 mm
85 – 150 Hz: 1 g
1 octave/min, 20 sweeps

9.6 Product group X-300M PoE

9.6.1 X-300M PoE approvals, certificates

Approvals issued

Note

Issued approvals on the type plate of the device

The specified approvals apply only when the corresponding mark is printed on the product. You can check which of the following approvals have been granted for your product by the markings on the type plate.

Approvals for shipbuilding are not printed on the device type plate.

Note

Shipbuilding approval

You will find shipbuilding approvals on the Internet on the pages of Siemens Industry Automation Customer Support under the following entry ID:

33118441 (<http://support.automation.siemens.com/WW/view/en/33118441>)
"Entry list" tab > entry type "Certificates"

EC directives

SIMATIC NET products meet the requirements and aims of the following EC directives.

EMC directive (electromagnetic compatibility)

The SIMATIC NET products described in these operating instructions meet the requirements of EC directive 2004/108/EC "Electromagnetic Compatibility" for the following areas of application:

Field of application	Requirements	
	Emission	Immunity to interference
Industry	EN 61000-6-4 : 2007	EN 61000-6-2 : 2005

WARNING

Personal injury and property damage can occur

The installation of expansions that are not approved for SIMATIC NET products or their target systems may violate the requirements and regulations for safety and electromagnetic compatibility.

Only use expansions that are approved for the system.

- Keep to the installation guidelines**
 The devices meet the requirements if you adhere to the installation and safety instructions contained in this documentation and in the following documentation when installing and operating the devices.
- You can always find the latest documentation on the Internet**
 The current descriptions of the currently available products can always be found on the Internet under the specified entry IDs/Internet pages:
 - "Industrial Ethernet / PROFINET Industrial Ethernet" System Manual
 - "Industrial Ethernet / PROFINET - Passive network components" System Manual

You will find information on the system manuals in the section "ID = 27069465 (<http://support.automation.siemens.com/WW/view/en/27069465>)", in "Further documentation".

 - "EMC Installation Guidelines" configuration manual
 ID = 60612658 (<http://support.automation.siemens.com/WW/view/en/60612658>)
- Working on the device**
 To protect the device from electrostatic discharge, personnel must first discharge any electrostatic charge from their body before touching the device.

Note

The test was performed with a device and a connected communications partner that also meets the requirements of the standards listed above.

When operating the device with a communications partner that does not comply with these standards, adherence to the corresponding values cannot be guaranteed.

Machinery directive

The product is a component in compliance with the EC Machinery Directive 2006/42/EEC. According to the machinery directive, we are obliged to point out that the product described is intended solely for installation in a machine.

Before the final product can be put into operation, it must be tested to ensure that it conforms with the directive 2006/42/EEC.

Note

Note for the manufacturers of machines

This product is not a machine in the sense of the EC Machinery Directive. There is therefore no declaration of conformity relating to the EC Machinery Directive 2006/42/EEC for this product.

ATEX (explosion protection directive)

 WARNING
When using SIMATIC NET products in hazardous area zone 2, make absolutely sure that the associated conditions in the following document are adhered to: "SIMATIC NET Product Information Use of subassemblies/modules in a Zone 2 Hazardous Area". You will find this document <ul style="list-style-type: none">• on the data medium that ships with some devices.• on the Internet pages of Siemens Industry Online Support (http://support.automation.siemens.com/WWW/view/en). Enter the document identification number C234 as the search term.

SIMATIC NET products meet the requirements of the EC directive:94/9/EC "Equipment and Protective Devices for Use in Potentially Explosive Atmospheres".

ATEX classification:

II 3 G Ex nA IIC T4 Gc

KEMA 07ATEX0145 X

The products meet the requirements of the following standards:

- EN 60079-15: 2010 (electrical apparatus for potentially explosive atmospheres; Type of protection "n")
- EN 60079-0: 2009 (Explosive atmospheres - Part 0: Equipment - General requirements)

IECEX

The SIMATIC NET products meet the requirements of explosion protection according to IECEX.

IECEX classification:

Ex nA IIC T4 Gc

DEK 14.0025X

The products meet the requirements of the following standards:

- IEC 60079-15 : 2010 (Explosive atmospheres - Part 15: Equipment protection by type of protection "n")
- IEC 60079-0 : 2011 (Explosive atmospheres - Part 0: Equipment - General requirements)

FM

The product meets the requirement of the standard:

- Factory Mutual Approval Standard Class Number 3611

C-Tick

The product meets the requirements of the AS/NZS 2064 standard (Class A).

cULus Approval for Information Technology Equipment

cULus Listed I. T. E.

Underwriters Laboratories Inc. complying with

- UL 60950-1 (Information Technology Equipment)
- CSA C22.2 No. 60950-1-03

Report no. E115352

cULus Approval Hazardous Location

cULus Listed I. T. E. FOR HAZ. LOC.

Underwriters Laboratories Inc. complying with

- UL 60950-1 (Information Technology Equipment)
- ANSI/ISA 12.12.01-2007
- CSA C22.2 No. 213-M1987

Approved for use in

Cl. 1, Div. 2, GP A, B, C, D T4

Cl. 1, Zone 2, GP IIC T4

Report no. E240480

9.6.2 SCALANCE X-300 declaration of conformity

You will find the EC Declaration of Conformity for these products on the Internet at the following address:

SCALANCE X-300 declaration of conformity

(<https://support.industry.siemens.com/cs/ww/en/ps/15296/cert>)

1. Click on the entry "SCALANCE X-300 managed" in the navigation panel at the top edge of the window and from the drop-down list that opens, select the entry for your product group.
2. Select the entry "Certificate" from the "Entry type" drop-down list.

Result: A list of the available certificates is displayed.

9.6.3 Overview of X-300M PoE approvals

Table 9- 6 Overview of the approvals

Device	c-UL-us Inf. Tech. Eq.	c-UL-us for Hazardous Locations ¹⁾	FM ¹⁾	C-TICK	CE	ATEX95 Zone 2 ¹⁾
X308-2M PoE	•	•	•	•	•	•

¹⁾ For temperature information "T.." or the maximum ambient temperature "Ta:..", refer to the type plate.

Note

Shipbuilding approval

You will find shipbuilding approvals on the Internet on the pages of Siemens Industry Automation Customer Support under the following entry ID:

Auto-Hotspot

"Entry list" tab > entry type "Certificates"

9.6.4 X-300M PoE mechanical stability in operation

The switch meets the following requirements for mechanical stability:

IEC 60068-2-6 (vibration)

- Securing on a DIN rail
 - 5 – 9 Hz: 3.5 mm
 - 9 – 150 Hz: 1 g
 - 1 octave/min, 20 sweeps

IEC 60068-2-27 (shock)

- Securing on a DIN rail
15 g, 11 ms duration, 6 shocks per axis

9.7 Product group XR-300M PoE

9.7.1 XR-300M PoE approvals, certificates

Approvals issued

Note**Issued approvals on the type plate of the device**

The specified approvals apply only when the corresponding mark is printed on the product. You can check which of the following approvals have been granted for your product by the markings on the type plate.

EC directives

SIMATIC NET products meet the requirements and aims of the following EC directives.

EMC directive (electromagnetic compatibility)

The SIMATIC NET products described in these operating instructions meet the requirements of EC directive 2004/108/EC "Electromagnetic Compatibility" for the following areas of application:

Field of application	Requirements	
	Emission	Immunity to interference
Industry	EN 61000-6-4 : 2007	EN 61000-6-2 : 2005

 WARNING**Personal injury and property damage can occur**

The installation of expansions that are not approved for SIMATIC NET products or their target systems may violate the requirements and regulations for safety and electromagnetic compatibility.

Only use expansions that are approved for the system.

- **Keep to the installation guidelines**
The devices meet the requirements if you adhere to the installation and safety

instructions contained in this documentation and in the following documentation when installing and operating the devices.

- **You can always find the latest documentation on the Internet**

The current descriptions of the currently available products can always be found on the Internet under the specified entry IDs/Internet pages:

- "Industrial Ethernet / PROFINET Industrial Ethernet" System Manual
- "Industrial Ethernet / PROFINET - Passive network components" System Manual

You will find information on the system manuals in the section "ID = 27069465 (<http://support.automation.siemens.com/WW/view/en/27069465>)", in "Further documentation".

- "EMC Installation Guidelines" configuration manual

ID = 60612658 (<http://support.automation.siemens.com/WW/view/en/60612658>)

- **Working on the device**

To protect the device from electrostatic discharge, personnel must first discharge any electrostatic charge from their body before touching the device.

Note

The test was performed with a device and a connected communications partner that also meets the requirements of the standards listed above.

When operating the device with a communications partner that does not comply with these standards, adherence to the corresponding values cannot be guaranteed.

Machinery directive

The product is a component in compliance with the EC Machinery Directive 2006/42/EEC. According to the machinery directive, we are obliged to point out that the product described is intended solely for installation in a machine.

Before the final product can be put into operation, it must be tested to ensure that it conforms with the directive 2006/42/EEC.

Note

Note for the manufacturers of machines

This product is not a machine in the sense of the EC Machinery Directive. There is therefore no declaration of conformity relating to the EC Machinery Directive 2006/42/EEC for this product.

FM

The product meets the requirements of the standards:

- Factory Mutual Approval Standard Class Number 3611
- FM Hazardous (Classified) Location Electrical Equipment:
Non Incendive / Class I / Division 2 / Groups A,B,C,D / T4 and
Non Incendive / Class I / Zone 2 / Group IIC / T4

Note

Only variants with 24 VDC power supply meet the requirements of this approval.

C-Tick

The product meets the requirements of the AS/NZS 2064 standard (Class A).

cULus Approval for Information Technology Equipment

cULus Listed I. T. E.

Underwriters Laboratories Inc. complying with

- UL 60950-1 (Information Technology Equipment)
- CSA C22.2 No. 60950-1-03

Report no. E115352

Note

Only variants with 24 VDC power supply meet the requirements of this approval.

cULus approval for industrial control equipment

cULus Listed IND. CONT. EQ.

Underwriters Laboratories Inc. complying with

- UL 508
- CSA C22.2 No. 142-M1987

Report no. E85972

Note

Only variants with 100 to 240 VAC power supply meet the requirements of this approval.

cULus Approval Hazardous Location

cULus Listed I. T. E. FOR HAZ. LOC.

Underwriters Laboratories Inc. complying with

- UL 60950-1 (Information Technology Equipment)
- ANSI/ISA 12.12.01-2007
- CSA C22.2 No. 213-M1987

Approved for use in

Cl. 1, Div. 2, GP A, B, C, D T4

Cl. 1, Zone 2, GP IIC T4

Report no. E240480

Note

Only variants with 24 VDC power supply meet the requirements of this approval.

Railway approval

The TS variant of the device meets the requirements of the Railway standard EN 50155:2007 "Railway Applications - Electronic equipment used on rolling stock".

Note

When used on railway stock, a stabilized power supply must be used to comply with EN50155.

9.7.2 SCALANCE X-300 declaration of conformity

You will find the EC Declaration of Conformity for these products on the Internet at the following address:

SCALANCE X-300 declaration of conformity

(<https://support.industry.siemens.com/cs/ww/en/ps/15296/cert>)

1. Click on the entry "SCALANCE X-300 managed" in the navigation panel at the top edge of the window and from the drop-down list that opens, select the entry for your product group.
2. Select the entry "Certificate" from the "Entry type" drop-down list.

Result: A list of the available certificates is displayed.

9.7.3 Overview of XR-300M PoE approvals

Table 9- 7 Overview of the approvals

Device	Variant	c-UL-us Inf. Tech. Eq.	c-UL-us for Hazard- ous Loca- tions ¹⁾	c-UL-us Ind. Cont. Eq.	FM ¹⁾	C-TICK	CE	ATEX95 Zone 2 ¹⁾
XR324-4M PoE	1 x 24 VDC	•	•	-	•	•	•	•
	1 x 100 to 240 VAC	-	-	•	-	•	•	-
XR324-4M PoE TS	1 x 24 VDC	•	•	-	•	•	•	•

¹⁾ For temperature information "T.." or the maximum ambient temperature "Ta:..", refer to the type plate.

9.7.4 XR-300M PoE mechanical stability in operation

The switch meets the following requirements for mechanical stability:

IEC 60068-2-6 (vibration)

- Mounting in the rack: (2-point mounting):
 - 10 to 58 Hz: 0.075 mm
 - 85 – 150 Hz: 1 g
 - 1 octave/min, 20 sweeps
- Individual mounting: (4-point mounting):
 - 5 to 8.51 Hz: 3.5 mm
 - 8.51 – 500 Hz: 1 g
 - 1 octave/min, 20 sweeps

IEC 60068-2-27 (shock)

- Mounting in the rack (2-point mounting):
 - 15 g, 11 ms duration, 6 shocks per axis

9.8 MM900 product group

9.8.1 MM900 approvals, certificates

Approvals issued

Note

Issued approvals on the type plate of the device

The specified approvals apply only when the corresponding mark is printed on the product. You can check which of the following approvals have been granted for your product by the markings on the type plate.

EC directives

SIMATIC NET products meet the requirements and aims of the following EC directives.

EMC directive (electromagnetic compatibility)

The SIMATIC NET products described in these operating instructions meet the requirements of EC directive 2004/108/EC "Electromagnetic Compatibility" for the following areas of application:

Field of application	Requirements	
	Emission	Immunity to interference
Industry	EN 61000-6-4 : 2007	EN 61000-6-2 : 2005

WARNING

Personal injury and property damage can occur

The installation of expansions that are not approved for SIMATIC NET products or their target systems may violate the requirements and regulations for safety and electromagnetic compatibility.

Only use expansions that are approved for the system.

- **Keep to the installation guidelines**
The devices meet the requirements if you adhere to the installation and safety instructions contained in this documentation and in the following documentation when installing and operating the devices.
- **You can always find the latest documentation on the Internet**
The current descriptions of the currently available products can always be found on the Internet under the specified entry IDs/Internet pages:
 - "Industrial Ethernet / PROFINET Industrial Ethernet" System Manual
 - "Industrial Ethernet / PROFINET - Passive network components" System Manual
You will find information on the system manuals in the section "ID = 27069465 (<http://support.automation.siemens.com/WW/view/en/27069465>)", in "Further documentation".
 - "EMC Installation Guidelines" configuration manual
ID = 60612658 (<http://support.automation.siemens.com/WW/view/en/60612658>)
- **Working on the device**
To protect the device from electrostatic discharge, personnel must first discharge any electrostatic charge from their body before touching the device.

Note

The test was performed with a device and a connected communications partner that also meets the requirements of the standards listed above.

When operating the device with a communications partner that does not comply with these standards, adherence to the corresponding values cannot be guaranteed.

Machinery directive

The product is a component in compliance with the EC Machinery Directive 2006/42/EEC. According to the machinery directive, we are obliged to point out that the product described is intended solely for installation in a machine.

Before the final product can be put into operation, it must be tested to ensure that it conforms with the directive 2006/42/EEC.

Note

Note for the manufacturers of machines

This product is not a machine in the sense of the EC Machinery Directive. There is therefore no declaration of conformity relating to the EC Machinery Directive 2006/42/EEC for this product.

9.8.1.1 ATEX (KEMA 07 ATEX0145 X)

ATEX (explosion protection directive)

 WARNING
When using SIMATIC NET products in hazardous area zone 2, make absolutely sure that the associated conditions in the following document are adhered to: "SIMATIC NET Product Information Use of subassemblies/modules in a Zone 2 Hazardous Area". You will find this document <ul style="list-style-type: none">• on the data medium that ships with some devices.• on the Internet pages of Siemens Industry Online Support (http://support.automation.siemens.com/WW/view/en). Enter the document identification number C234 as the search term.

SIMATIC NET products meet the requirements of the EC directive:94/9/EC "Equipment and Protective Devices for Use in Potentially Explosive Atmospheres".

ATEX classification:

II 3 G Ex nA IIC T4 Gc

KEMA 07ATEX0145 X

The products meet the requirements of the following standards:

- EN 60079-15: 2010 (electrical apparatus for potentially explosive atmospheres; Type of protection "n")
- EN 60079-0: 2009 (Explosive atmospheres - Part 0: Equipment - General requirements)

ATEX classification

II 3 (2) G Ex nA [op is Gb] IIC T4 Gc

DEKRA 11 ATEX 0060 X

These products meet the requirements of the standards

- EN 60079-15: 2010
- EN 60079-0:2009
- EN 60079-28: 2007

Note

Only the media modules MM991-2 meet the requirements of this approval.

IECEX

The SIMATIC NET products meet the requirements of explosion protection according to IECEX.

IECEX classification:

Ex nA IIC T4 Gc

DEK 14.0025X

The products meet the requirements of the following standards:

- IEC 60079-15 : 2010 (Explosive atmospheres - Part 15: Equipment protection by type of protection "n")
- IEC 60079-0 : 2011 (Explosive atmospheres - Part 0: Equipment - General requirements)

IECEX (optical radiation)

The SIMATIC NET products meet the requirements of explosion protection according to IECEX.

IECEX classification:

Ex nA [op is Gb] IIC T4 Gc

DEK 14.0026X

The products meet the requirements of the following standards:

- IEC 60079-15 (Explosive atmospheres - Part 15: Equipment protection by type of protection "n")
- IEC 60079-0 (Explosive atmospheres - Part 0: Equipment - General requirements)
- IEC 60079-28 (Explosive atmospheres - Part 28: Protection of equipment and transmission systems using with optical radiation)

You will find the current versions of the standards in the currently valid IECEX certificates.

Note

Only the media modules MM991-2 meet the requirements of this approval.

FM

The product meets the requirements of the standards:

- Factory Mutual Approval Standard Class Number 3611
- FM Hazardous (Classified) Location Electrical Equipment:
Non Incendive / Class I / Division 2 / Groups A,B,C,D / T4 and
Non Incendive / Class I / Zone 2 / Group IIC / T4

cULus Approval for Information Technology Equipment

cULus Listed I. T. E.

Underwriters Laboratories Inc. complying with

- UL 60950-1 (Information Technology Equipment)
- CSA C22.2 No. 60950-1-03

Report no. E115352

cULus approval for industrial control equipment

cULus Listed IND. CONT. EQ.

Underwriters Laboratories Inc. complying with

- UL 508
- CSA C22.2 No. 142-M1987

Report no. E85972

cULus Approval Hazardous Location

cULus Listed I. T. E. FOR HAZ. LOC.

Underwriters Laboratories Inc. complying with

- UL 60950-1 (Information Technology Equipment)
- ANSI/ISA 12.12.01-2007
- CSA C22.2 No. 213-M1987

Approved for use in

Cl. 1, Div. 2, GP A, B, C, D T4

Cl. 1, Zone 2, GP IIC T4

Report no. E240480

Railway approval

The following media modules meets the requirements of the Railway standard EN 50155:2007 "Railway Applications - Electronic equipment used on rolling stock".

- MM992-2 (C)
- MM992-2CUC (C)
- MM992-2 M12 (C)

Media modules with the supplement (C) in the type name have varnished printed circuit boards (conformal coating).

Note

When used on railway stock, a stabilized power supply must be used to comply with EN50155.

9.8.2 MM900 declaration of conformity

Declaration of conformity

You will find the EU declaration of conformity for these products on the Internet under the following entry ID: 67218486

<http://support.automation.siemens.com/WW/view/en/67218486>

9.8.3 Overview of the MM900 approvals

Note

The MM900 media modules only have UL60950, C-Tick, CE, FM and ATEX approvals. The other approvals are device approvals and are obtained for the device with the various components.

Table 9- 8 Overview of the approvals

Device: SCALANCE	(Variant)	c-UL-us	c-UL-us for hazard- ous loca- tions ¹	FM ¹	C-TICK	CE	ATEX95 Zone 2 ¹	E1
MM992-2CUC	(2 x 10/100/1000 Mbps, RJ-45 ports electrical with securing collar)	•	•	•	•	•	•	-
MM992-2CU	(2 x 10/100/1000 Mbps, RJ-45 ports electrical without securing collar)	•	•	•	•	•	•	-
MM992-2CU (C)	(2 x 10/100/1000 Mbps, RJ-45 ports electrical without securing collar, varnished)	•	•	•	•	•	•	-

Device: SCALANCE	(Variant)	c-UL-us	c-UL-us for hazard- ous loca- tions ¹	FM ¹	C-TICK	CE	ATEX95 Zone 2 ¹	E1
MM992-2M12 (C)	(2 x 10/100/1000 Mbps, GE M12 connector electrical, varnished)	•	•	•	•	•	•	-
MM992-2VD	(2 x 10/100/1000 Mbps, RJ-45 ports electrical with se-curing collar)	•	•	•	•	•	•	-
MM992-2SFP	(2x 100/1000 Mbps, SFP media module)	•	•	•	•	•	•	-
MM991-2	(2 x 100 Mbps, BFOC ports optical, multimode glass, up to max. 3 km)	•	•	•	•	•	•	-
MM991-2FM	(2 x 100 Mbps, BFOC port optical (multimode, glass) with diagnostics up to max. 5 km)	•	•	•	•	•	•	-
MM991-2LD	(2 x 100 Mbps, BFOC ports optical, single mode glass, up to max. 26km)	•	•	•	•	•	•	-
MM991-2 (SC)	(2 x 100 Mbps, SC ports optical, multi-mode glass, up to max. 3 km)	•	•	•	•	•	•	-
MM991-2LD (SC)	(2 x 100 Mbps, SC ports optical, single mode glass, up to max. 26km)	•	•	•	•	•	•	-
MM991-2LH+ (SC)	(2 x 100 Mbps, SC ports optical, single mode glass, up to max. 70km)	•	•	•	•	•	•	-
MM991-2P	(2 x 100 Mbps SC RJ ports optical for Plastic Optical Fiber (POF) up to max. 50 m or Polymer Cladded Fiber (PCF) up to max. 100 m)	•	•	•	•	•	•	-
MM992-2	(2 x 1000 Mbps, SC ports optical, multi-mode glass, up to max. 750m)	•	•	•	•	•	•	-
MM992-2 (C)	(2 x 1000 Mbps, SC ports optical, for glass FO cable (multimode), up to max. 750 m, var-nished)	•	•	•	•	•	•	-

Device: SCALANCE	(Variant)	c-UL-us	c-UL-us for hazard- ous loca- tions ¹	FM ¹	C-TICK	CE	ATEX95 Zone 2 ¹	E1
MM992-2LD	(2 x 1000 Mbps, SC ports optical, single mode glass, up to max. 10km)	•	•	•	•	•	•	-
MM992-2LH	(2 x 1000 Mbps, SC ports optical, single mode glass, up to max. 40km)	•	•	•	•	•	•	-
MM992-2LH+	(2 x 1000 Mbps, SC ports optical, single mode glass, up to max. 70km)	•	•	•	•	•	•	-
MM992-2ELH	(2 x 1000 Mbps, SC ports optical, single mode glass, up to max. 120km)	•	•	•	•	•	•	-

¹For temperature information "T.." or the maximum ambient temperature "Ta:..", refer to the type plate.

Note

Shipbuilding approval

The shipbuilding approval applies to all MM900 media modules.

9.8.4 MM900 FDA and IEC approvals

The following MM900 media modules meet the FDA and IEC requirements listed below:

Media module	Fulfills FDA and IEC requirements
MM992-2CUC	-
MM992-2CUC (C)	-
MM992-2CU	-
MM992-2M12 (C)	-
MM992-2VD	-
MM992-2SFP ^{*)}	-
MM991-2	CLASS 1 LED Product
MM991-2FM	CLASS 1 LED Product
MM991-2LD	CLASS 1 LASER Product
MM991-2 (SC)	CLASS 1 LED Product
MM991-2LD (SC)	CLASS 1 LASER Product
MM991-2LH+ (SC)	CLASS 1 LASER Product
MM992-2	CLASS 1 LASER Product
MM992-2 (C)	CLASS 1 LASER Product

Media module	Fulfills FDA and IEC requirements
MM992-2LD	CLASS 1 LASER Product
MM992-2LH	CLASS 1 LASER Product
MM992-2LH+	CLASS 1 LASER Product
MM992-2ELH	CLASS 1 LASER Product

) You will find further information in the compact operating instructions "Transceiver SFP/SFP+".



Image 9-7 FDA and IEC approvals

9.9 Product group SFP

9.9.1 Approvals, certificates

Approvals issued

Note

Issued approvals on the type plate of the device

The specified approvals apply only when the corresponding mark is printed on the product. You can check which of the following approvals have been granted for your product by the markings on the type plate.

EC directives

SIMATIC NET products meet the requirements and aims of the following EC directives.

EMC directive (electromagnetic compatibility)

The SIMATIC NET products described in these operating instructions meet the requirements of EC directive 2004/108/EC "Electromagnetic Compatibility" for the following areas of application:

Field of application	Requirements	
	Emission	Immunity to interference
Industry	EN 61000-6-4 : 2007	EN 61000-6-2 : 2005

WARNING

Personal injury and property damage can occur

The installation of expansions that are not approved for SIMATIC NET products or their target systems may violate the requirements and regulations for safety and electromagnetic compatibility.

Only use expansions that are approved for the system.

- **Keep to the installation guidelines**
The devices meet the requirements if you adhere to the installation and safety instructions contained in this documentation and in the following documentation when installing and operating the devices.
- **You can always find the latest documentation on the Internet**
The current descriptions of the currently available products can always be found on the Internet under the specified entry IDs/Internet pages:
 - "Industrial Ethernet / PROFINET Industrial Ethernet" System Manual
 - "Industrial Ethernet / PROFINET - Passive network components" System Manual

You will find information on the system manuals in the section "ID = 27069465 (<http://support.automation.siemens.com/WW/view/en/27069465>)", in "Further documentation".

 - "EMC Installation Guidelines" configuration manual
ID = 60612658 (<http://support.automation.siemens.com/WW/view/en/60612658>)
- **Working on the device**
To protect the device from electrostatic discharge, personnel must first discharge any electrostatic charge from their body before touching the device.

Note

The test was performed with a device and a connected communications partner that also meets the requirements of the standards listed above.

When operating the device with a communications partner that does not comply with these standards, adherence to the corresponding values cannot be guaranteed.

Machinery directive

The product is a component in compliance with the EC Machinery Directive 2006/42/EEC. According to the machinery directive, we are obliged to point out that the product described is intended solely for installation in a machine.

Before the final product can be put into operation, it must be tested to ensure that it conforms with the directive 2006/42/EEC.

Note

Note for the manufacturers of machines

This product is not a machine in the sense of the EC Machinery Directive. There is therefore no declaration of conformity relating to the EC Machinery Directive 2006/42/EEC for this product.

Note for the manufacturers of machines

This product is not a machine in the sense of the EC Machinery Directive. There is therefore no declaration of conformity relating to the EC Machinery Directive 89/392/EEC for this product.

ATEX (explosion protection directive)

 WARNING
<p>When using SIMATIC NET products in hazardous area zone 2, make absolutely sure that the associated conditions in the following document are adhered to:</p> <p>"SIMATIC NET Product Information Use of subassemblies/modules in a Zone 2 Hazardous Area".</p> <p>You will find this document</p> <ul style="list-style-type: none"> • on the data medium that ships with some devices. • on the Internet pages of Siemens Industry Online Support (http://support.automation.siemens.com/WWW/view/en). <p>Enter the document identification number C234 as the search term.</p>

SIMATIC NET products meet the requirements of the EC directive:94/9/EC "Equipment and Protective Devices for Use in Potentially Explosive Atmospheres".

ATEX classification:

II 3 G Ex nA IIC T4 Gc

KEMA 07ATEX0145 X

The products meet the requirements of the following standards:

- EN 60079-15: 2010 (electrical apparatus for potentially explosive atmospheres; Type of protection "n")
- EN 60079-0: 2009 (Explosive atmospheres - Part 0: Equipment - General requirements)

IECEX

The SIMATIC NET products meet the requirements of explosion protection according to IECEX.

IECEX classification:

Ex nA IIC T4 Gc

DEK 14.0025X

The products meet the requirements of the following standards:

- IEC 60079-15 : 2010 (Explosive atmospheres - Part 15: Equipment protection by type of protection "n")
- IEC 60079-0 : 2011 (Explosive atmospheres - Part 0: Equipment - General requirements)

FM

The product meets the requirements of the standards:

- Factory Mutual Approval Standard Class Number 3611
- FM Hazardous (Classified) Location Electrical Equipment:
Non Incendive / Class I / Division 2 / Groups A,B,C,D / T4 and
Non Incendive / Class I / Zone 2 / Group IIC / T4

C-Tick

The product meets the requirements of the AS/NZS 2064 standard (Class A).

Note

The SFP transceivers do not have UL listing but a c-UR-us approval (component approval).

cULus Approval for Information Technology Equipment

cULus Listed I. T. E.

Underwriters Laboratories Inc. complying with

- UL 60950-1 (Information Technology Equipment)
- CSA C22.2 No. 60950-1-03

Report no. E115352

9.9.2 SFP type plate



Image 9-8 SFP specimen type plate top

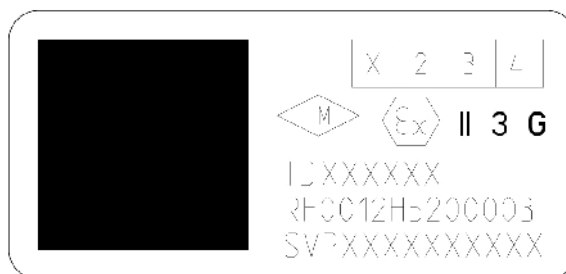

Image 9-9 SFP specimen type plate bottom

9.9.3 SFP declaration of conformity

Declaration of conformity

You will find the EC Declaration of Conformity for these products on the Internet at the following address:

<http://support.automation.siemens.com/WW/view/en/67218486>
 (<http://support.automation.siemens.com/WW/view/en/67218486>)

- > Entry list
- > Entry type "Certificates"
- > Certificate type "Declaration of Conformity"

Example German: "EG-Konformitätserklärung SCALANCE X310",
 Example English: "Declaration of Conformity SCALANCE X310".

9.9.4 SFP FDA and IEC approvals

The following devices meet the FDA and IEC requirements listed below:

Product line	Product group	Device: Transceiver	(Variant)	Fulfills FDA and IEC requirements
X-300	SFP	SFP991-1	(1 x 100 Mbps, LC port optical, multimode glass, up to max. 3 km)	•
		SFP991-1LD	(1 x 100 Mbps, LC port optical, single mode glass, up to max. 26 km)	•
		SFP991-1LH+	(1 x 100 Mbps, LC port optical, single mode glass, up to max. 70km)	•
		SFP992-1	(1 x 1000 Mbps, LC port optical, multimode glass, up to max. 750m)	•
		SFP992-1LD	(1 x 1000 Mbps, LC port optical, single mode glass, up to max. 10km)	•
		SFP992-1LH	(1 x 1000 Mbps, LC port optical, single mode glass, up to max. 40km)	•
		SFP992-LH+	(1 x 1000 Mbps, LC port optical, single mode glass, up to max. 70km)	•
		SFP992-1ELH	(1 x 1000 Mbps, LC port optical, single mode glass, up to max. 120km)	•



Image 9-10 FDA and IEC approvals

9.9.5 Overview of the SFP approvals

Note

The SFP transceivers only have UL60950, C-Tick, CE, FM and ATEX approvals. The other approvals are device approvals and are obtained for the device with the various components.

Table 9- 9 Overview of the approvals

Device: Pluggable trans- ceiver	(Variant)	c-UL-us	FM ¹	C-TICK	CE	ATEX95 Zone 2 ¹	E1
SFP991-1	(1 x 100 Mbps, LC port optical, multi-mode glass, up to max. 3 km)	•	•	•	•	•	-
SFP991-1LD	(1 x 100 Mbps, LC port optical, single mode glass, up to max. 26 km)	•	•	•	•	•	-
SFP991-1LH+	(1 x 100 Mbps, LC port optical, single mode glass, up to max. 70km)	•	•	•	•	•	-
SFP992-1	(1 x 1000 Mbps, LC port optical, multi-mode glass, up to max. 750m)	•	•	•	•	•	-
SFP992-1LD	(1 x 1000 Mbps, LC port optical, single mode glass, up to max. 10km)	•	•	•	•	•	-
SFP992-1LH	(1 x 1000 Mbps, LC port optical, single mode glass, up to max. 40km)	•	•	•	•	•	-
SFP992-LH+	(1 x 1000 Mbps, LC port optical, single mode glass, up to max. 70km)	•	•	•	•	•	-
SFP992-1ELH	(1 x 1000 Mbps, LC port optical, single mode glass, up to max. 120km)	•	•	•	•	•	-

¹For temperature information "T.." or the maximum ambient temperature "Ta:..", refer to the table of environmental conditions.

Note

Shipbuilding approval

The shipbuilding approval applies to all SFP transceivers.

9.9.6 SFP mechanical stability (in operation)

Device: transceiver	(Variant)	IEC 60068-2-6 vibration	IEC 60068-2-27 shock
		5 – 9 Hz: 3.5 mm 9 – 150 Hz: 1 g 1 octave/min, 20 sweeps	15 g, 11 ms duration 6 shocks per axis
SFP991-1	(1 x 100 Mbps, LC port optical, multimode glass, up to max. 3 km)	•	•
SFP991-1LD	(1 x 100 Mbps, LC port optical, single mode glass, up to max. 26 km)	•	•
SFP991-1LH+	(1 x 100 Mbps, LC port optical, single mode glass, up to max. 70km)	•	•
SFP992-1	(1 x 1000 Mbps, LC port optical, multimode glass, up to max. 750m)	•	•
SFP992-1LD	(1 x 1000 Mbps, LC port optical, single mode glass, up to max. 10km)	•	•
SFP992-1LH	(1 x 1000 Mbps, LC port optical, single mode glass, up to max. 40km)	•	•
SFP992-LH+	(1 x 1000 Mbps, LC port optical, single mode glass, up to max. 70km)	•	•
SFP992-1ELH	(1 x 1000 Mbps, LC port optical, single mode glass, up to max. 120km)	•	•

Accessories

10.1 Accessories

Table 10- 1 Accessories and order numbers

Product	Order number	Available for SCALANCE ...
"Industrial Ethernet TP and Fiber Optic Networks" manual	6GK1970-1BA10-0AA0	All switches
Cables and accessories		
IE FC Stripping Tool	6GK1901-1GA00	For IE cables
IE FC blade cassettes	6GK1901-1GB00	For stripping tool
IE FC TP standard cable GP	6XV1840-2AH10	
IE FC TP trailing cable	6XV1840-3AH10	
IE FC TP marine cable	6XV1840-4AH10	
IE FC TP trailing cable GP	6XV1870-2D	
IE FC TP flexible cable GP	6XV1870-2B	
IE FC FRNC cable GP	6XV1871-2F	
IE FC ground cable	6XV1871-2G	
IE FC TP festoon cable GP	6XV1871-2S	
IE FC ground cable	6XV1871-2G	
IE TP train cable, 2 x 2, CAT5	6XV1871-2T	
IE FC TP food cable	6XV1871-2L	
IE TP torsion cable	6XV1870-2F	
IE FC Standard Cable, 4 x 2, AWG24	6XV1878-2A	(gigabit cable)
IE FC Flexible Cable, 4 x 2, AWG24	6XV1878-2B	(gigabit cable)
IE TP train cable, 4 x 2, CAT7	6XV1878-2T	
PROFIBUS FC standard cable GP	6XV1830-0EH10	
Fast Ethernet connector		
IE FC RJ-45 Plug 180 pack of 1	6GK1901-1BB10-2AA0	For all electrical Fast Ethernet ports
IE FC RJ-45 Plug 180 pack of 10	6GK1901-1BB10-2AB0	For all electrical Fast Ethernet ports
IE FC RJ-45 Plug 180 pack of 50	6GK1901-1BB10-2AE0	For all electrical Fast Ethernet ports
Gigabit connector		
IE FC RJ-45 Plug 180, 4 x 2, pack of 1	6GK1901-1BB11-2AA0	For all electrical gigabit ports
IE FC RJ-45 Plug 180, 4 x 2, pack of 10	6GK1901-1BB11-2AB0	For all electrical gigabit ports
IE FC RJ-45 Plug 180 4 x 2, pack of 50	6GK1901-1BB11-2AE0	For all electrical gigabit ports
FO connectors and accessories		
FC FO Standard Cable GP (62.5/200/230)	6XV1847-2A	
FC FO Trailing Cable (62.5/200/230)	6XV1847-2C	
Crimp and Cleave assembly case for FC FO system	6GK1900-1GL00-0AB0	
FC BFOC connector set with cleaning cloths and dust protection cap, pack of 20	6GK1900-1GB00-0AC0	
FC SC connector set with cleaning cloths and dust protection cap, pack of 20 = 10 duplex connectors	6GK1900-1LB00-0AC0	

Accessories

10.1 Accessories

Product	Order number	Available for SCALANCE ...
FC BFOC coupler, 10 single couplings	6GK1900-1GP00-0AB0	
FC SC coupler, 5 duplex couplings	6GK1900-1LP00-0AB0	
C-PLUG		
C-PLUG	6GK1900-0AB00	SCALANCE X-200 / X-300 / X-400

Graphics

11.1 Dimension drawing

Note

The IE Switches X-300 are available in small, medium and large variants.
The dimension drawings are shown below.

Small design

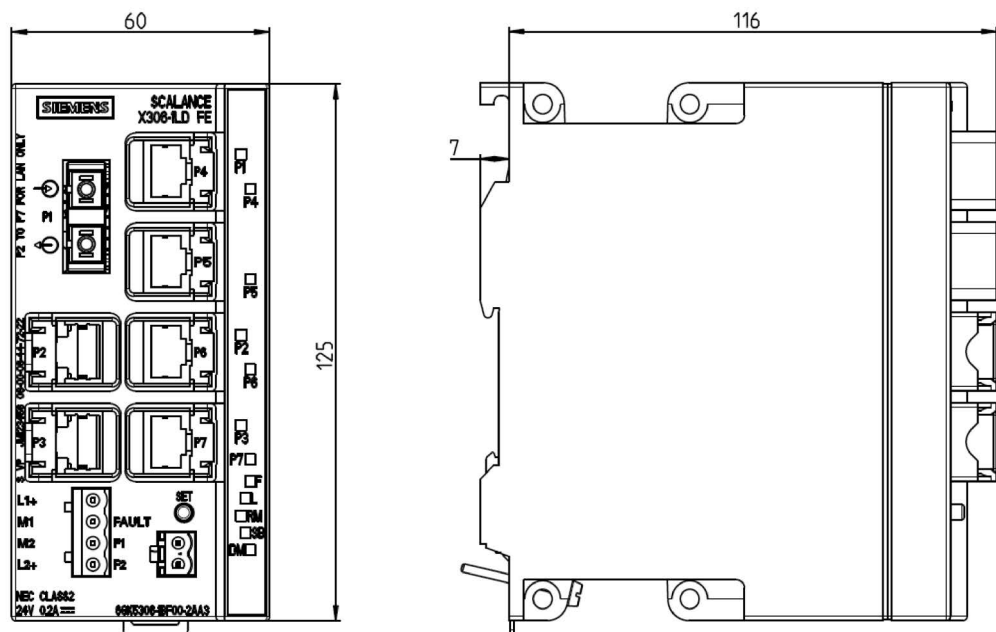

Image 11-1 Small design dimension drawing (example used here SCALANCE X306-1LD FE)

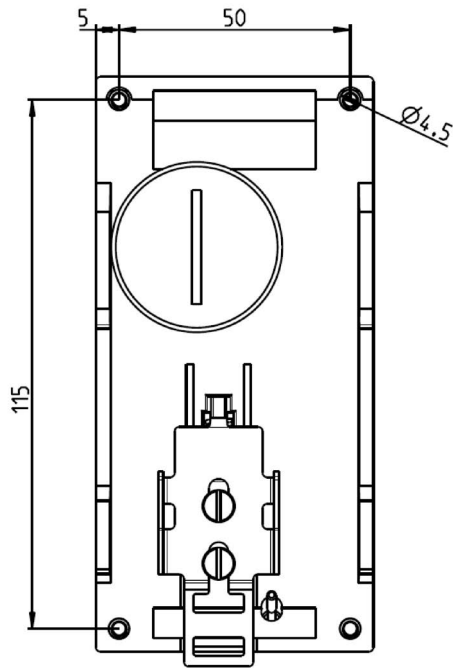

Image 11-2 Small design dimension drawing (IE Switch X-306)

Medium design

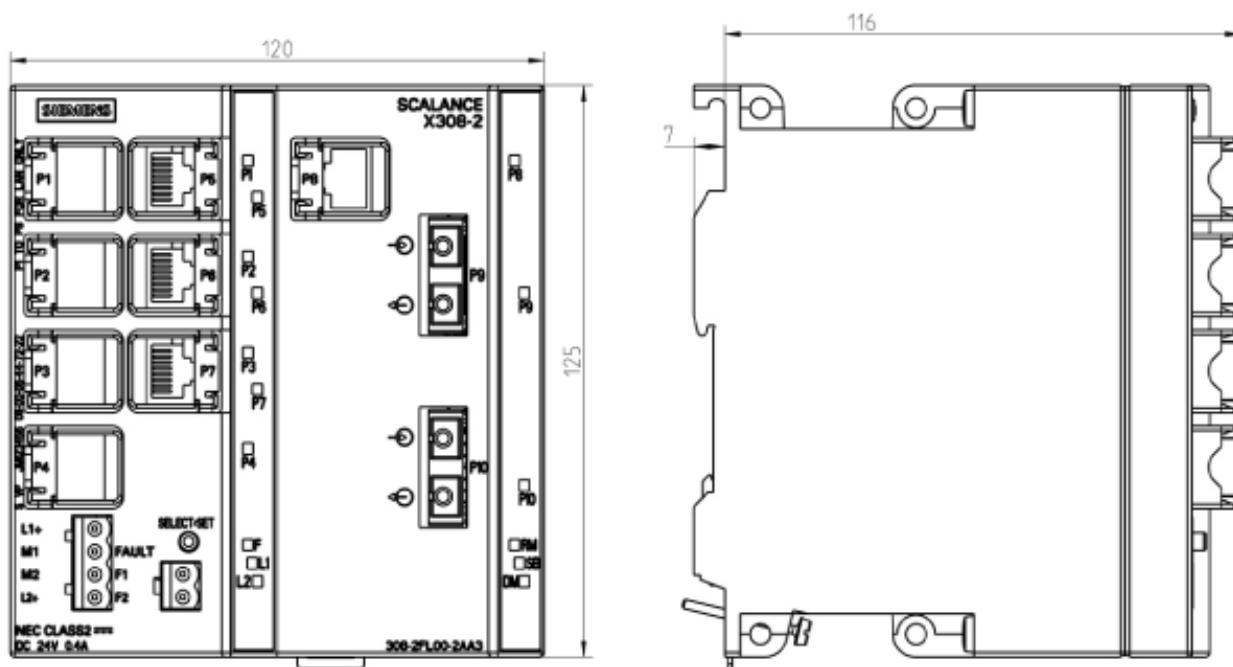

Image 11-3 Medium design dimension drawing (example used here SCALANCE X308-2)

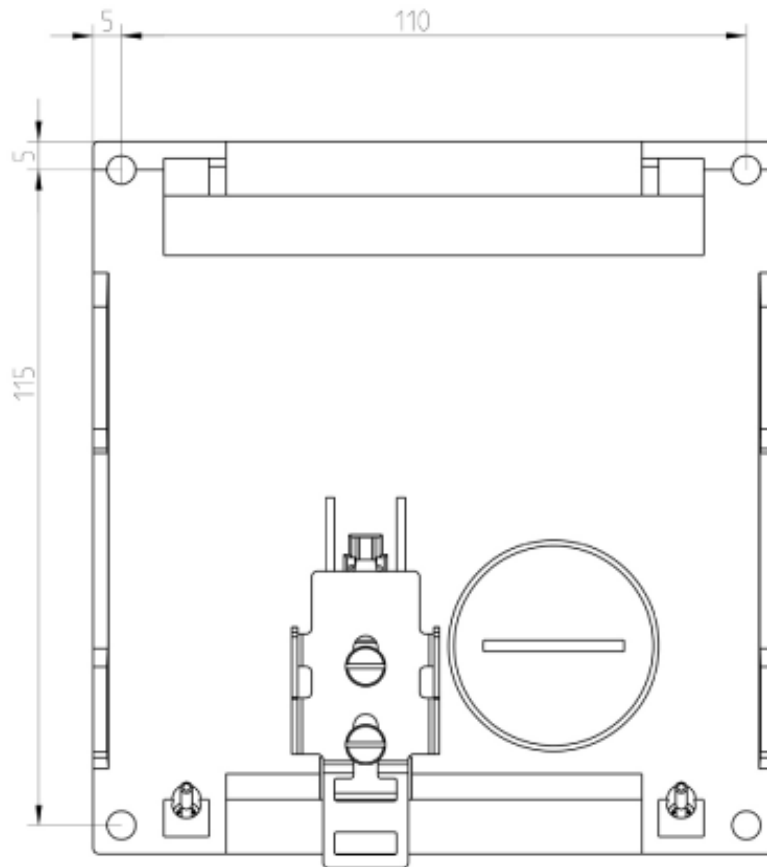

Image 11-4 Medium design dimension drawing (IE Switch X-300)

Large design

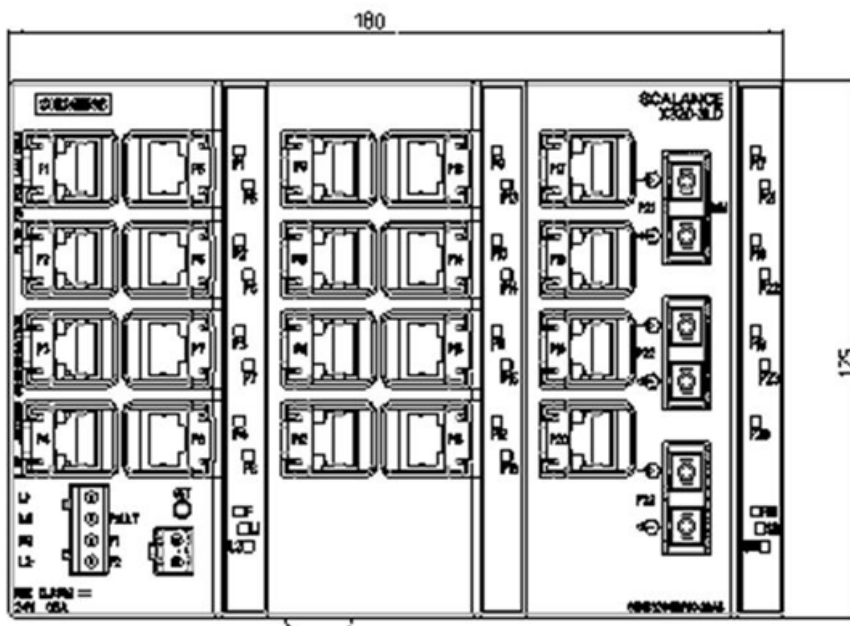

Image 11-5 Large design dimension drawing Part 1 (example used here SCALANCE X320-3LD FE)

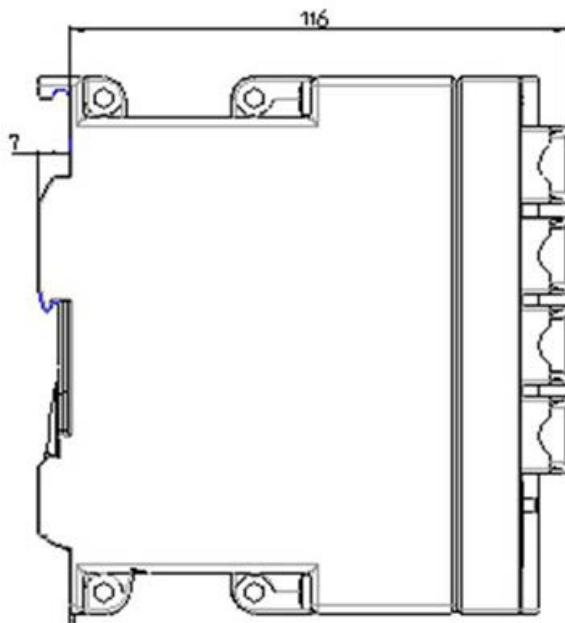

Image 11-6 Large design dimension drawing Part 2 (example used here SCALANCE X320-3LD FE)

11.1 Dimension drawing

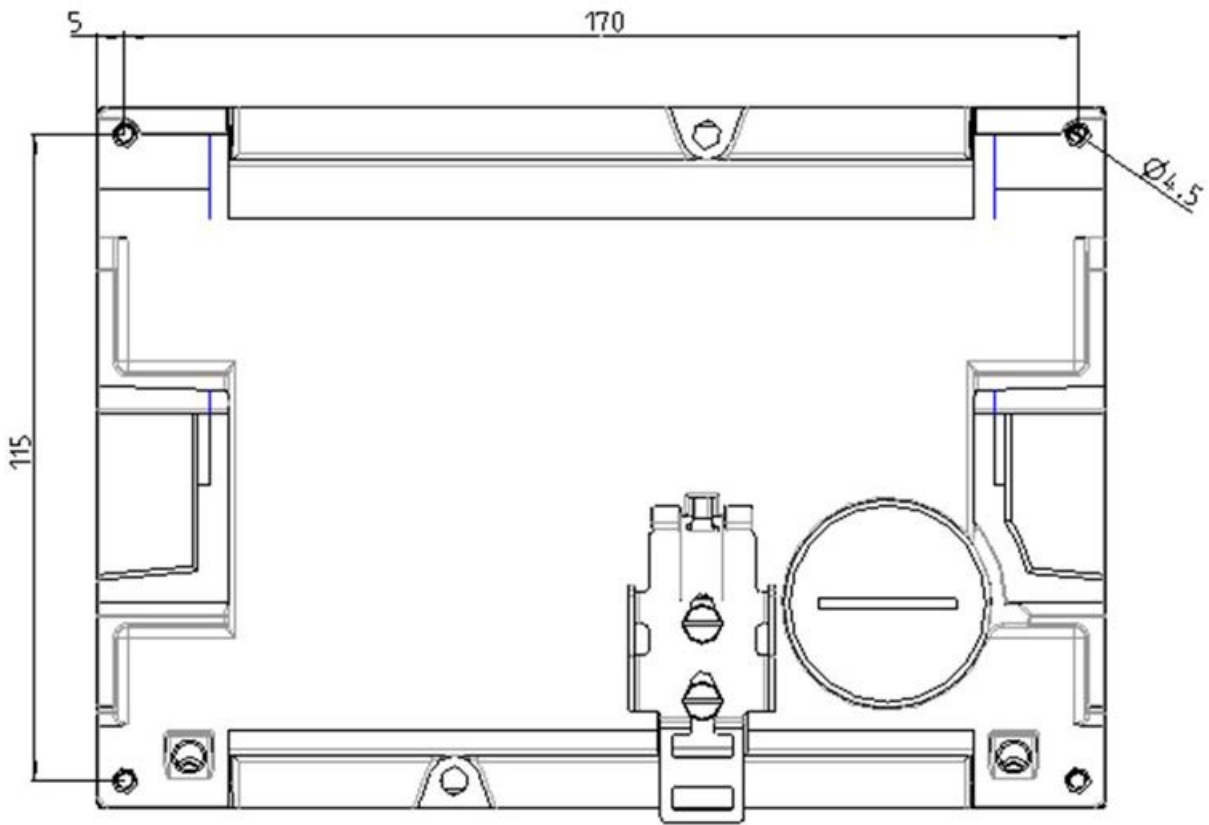

Image 11-7 Large design dimension drawing (IE Switch X-320)

11.2 X-300M dimension drawings

Note

The following dimension drawings are available for the X-300M product group.

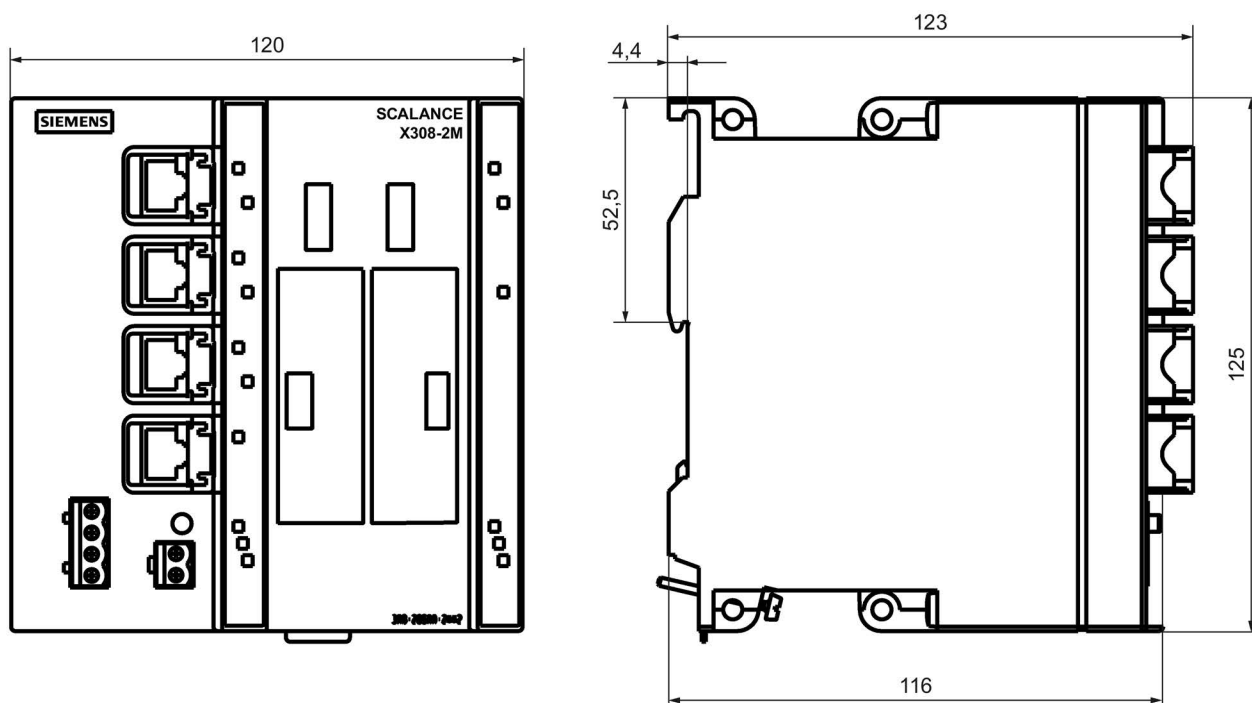

Image 11-8 X308-2M dimension drawing

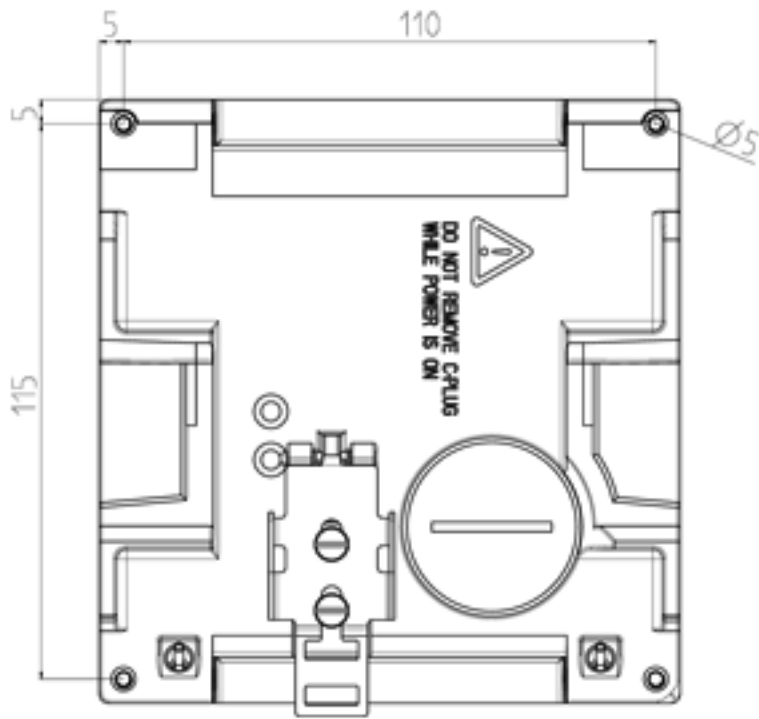

Image 11-9 X308-2M drilling template

11.3 XR-300M dimension drawings

Note

The following dimension drawings are available for the **XR-300M** product group.



Image 11-10 Front view of the XR324-12M

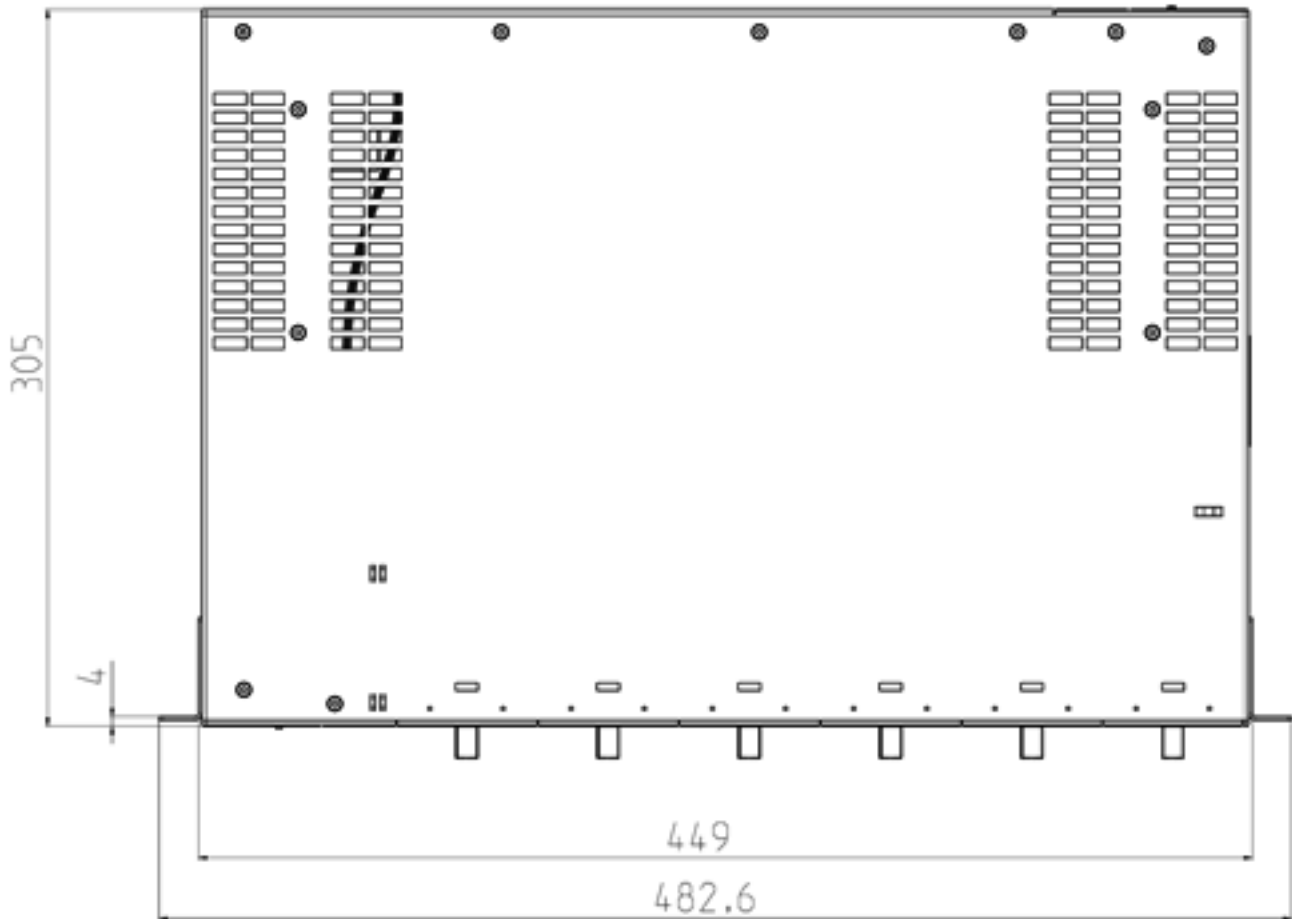

Image 11-11 XR324-12M from above

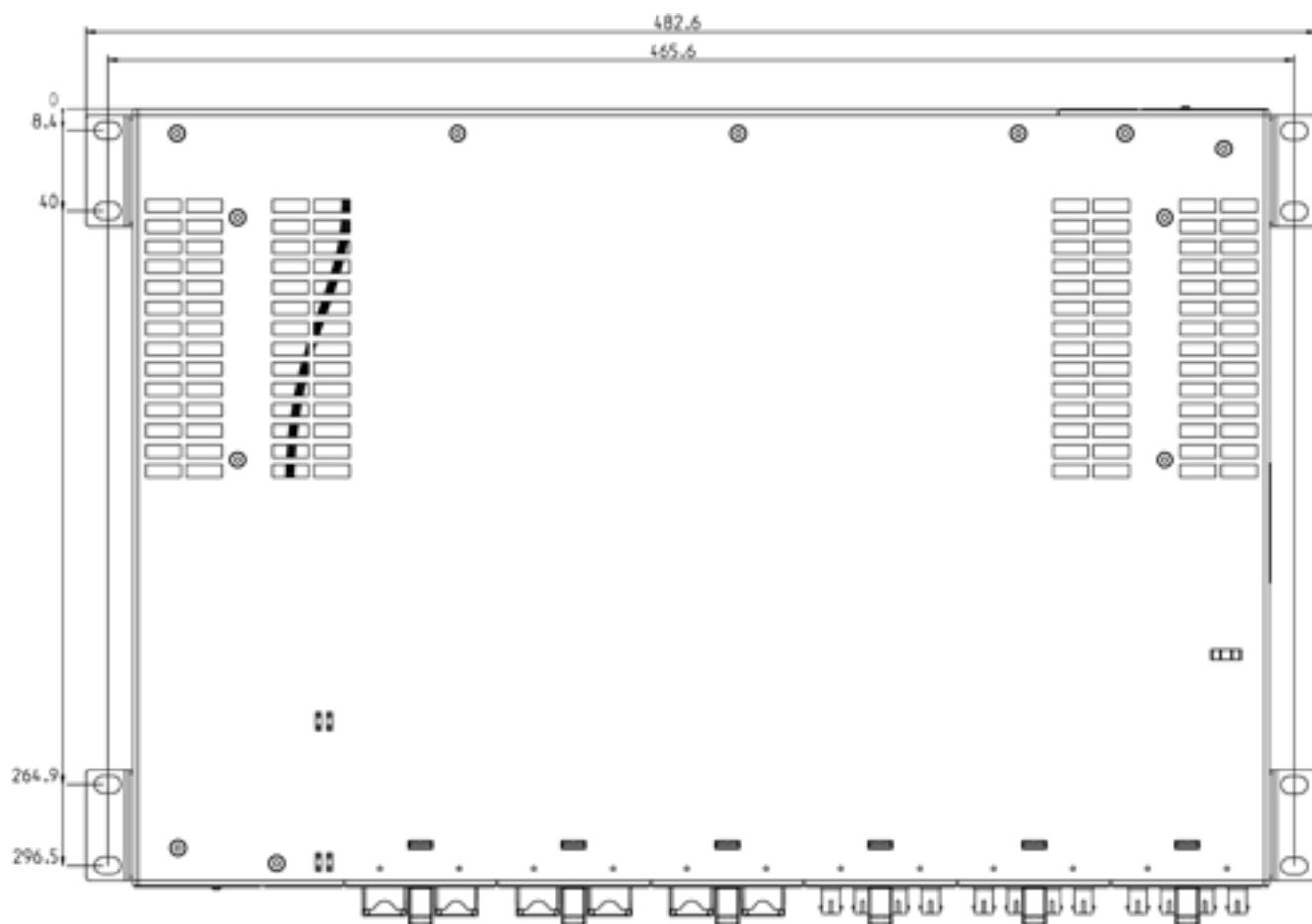

Image 11-12 XR324-12M from above

11.4 X-300EEC dimension drawings

All dimensions in the drawings are in millimeters

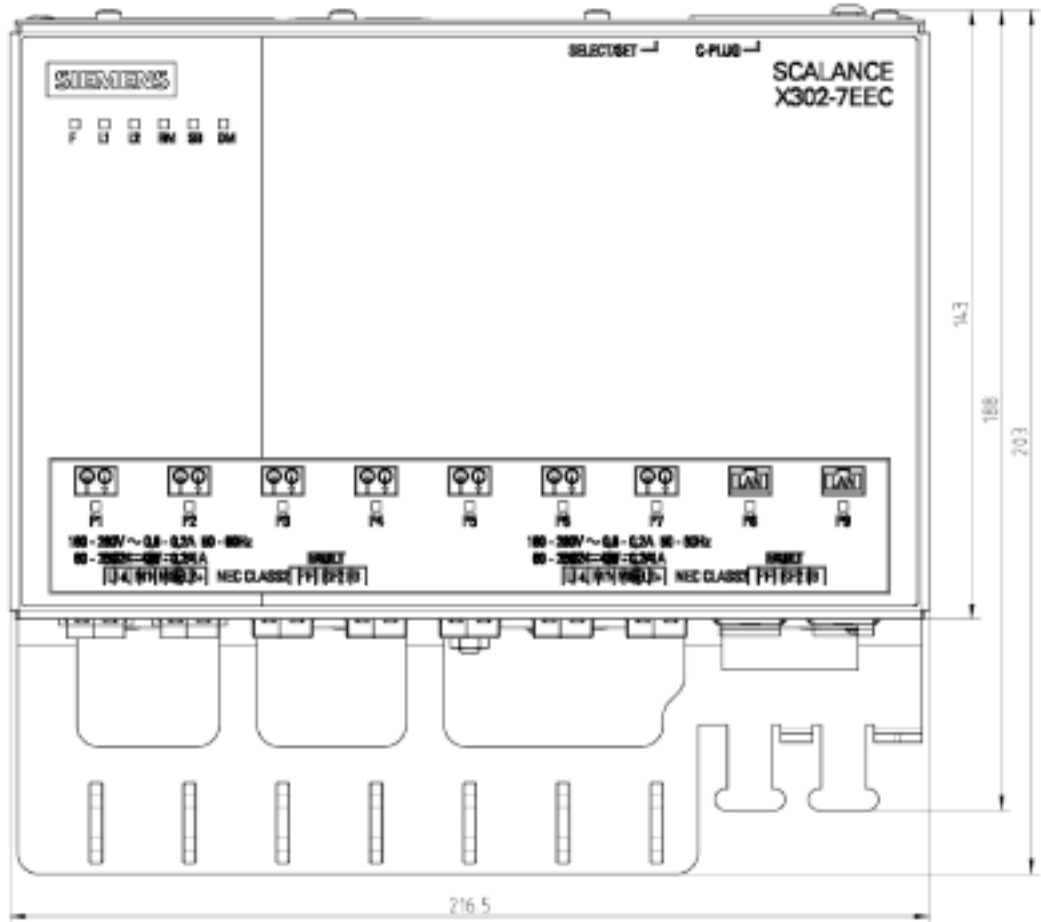

Image 11-13 Dimension drawing IE Switch X302-7EEC - view

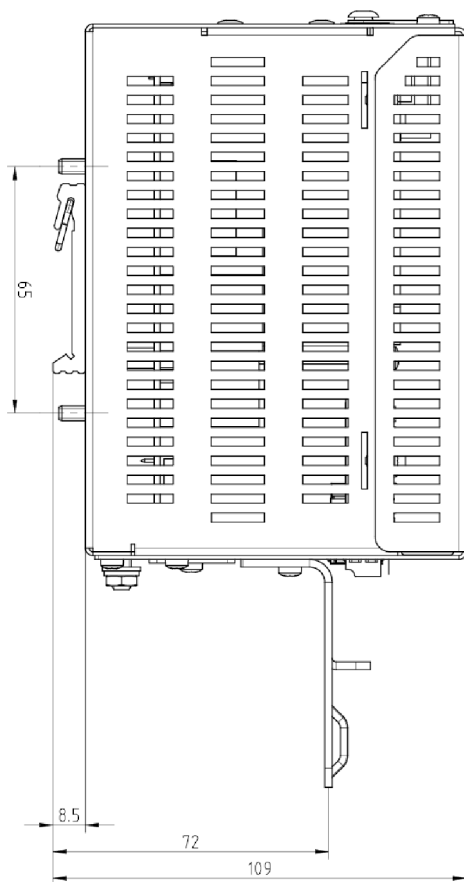

Image 11-14 Dimension drawing IE Switch X302-7EEC - side view

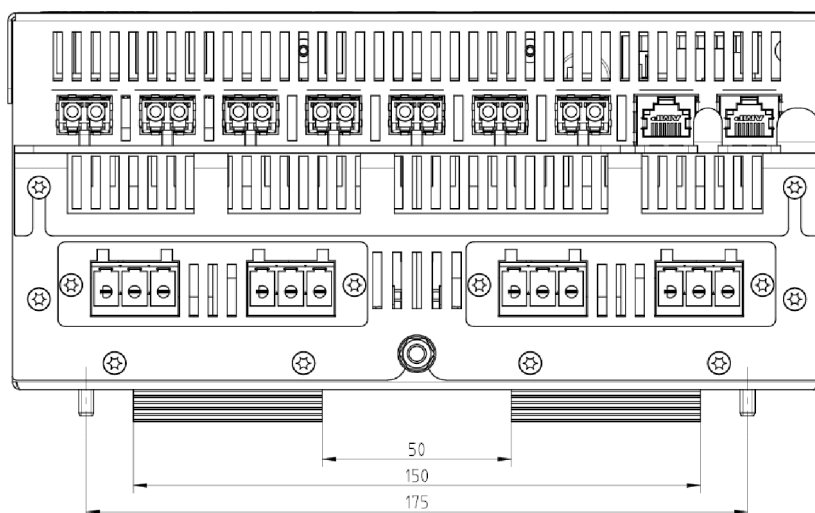

Image 11-15 Dimension drawing IE Switch X302-7EEC - from above

11.5 XR-300M EEC dimension drawings

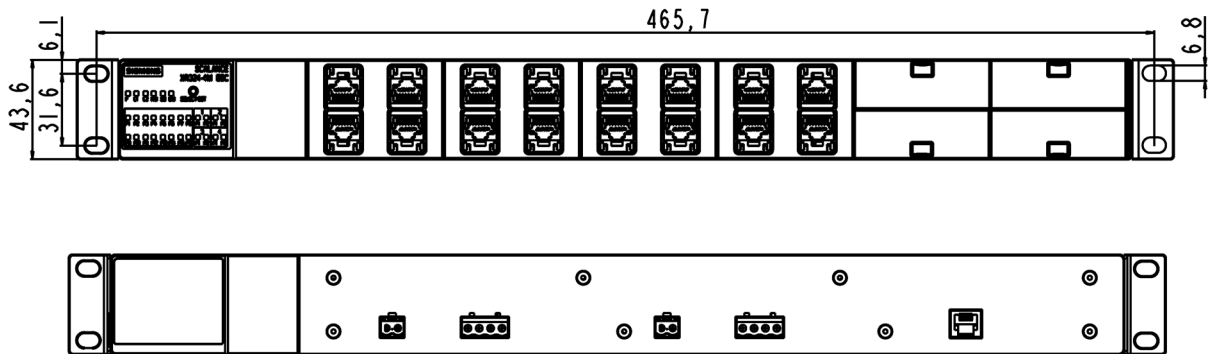

Image 11-16 Housing front and rear

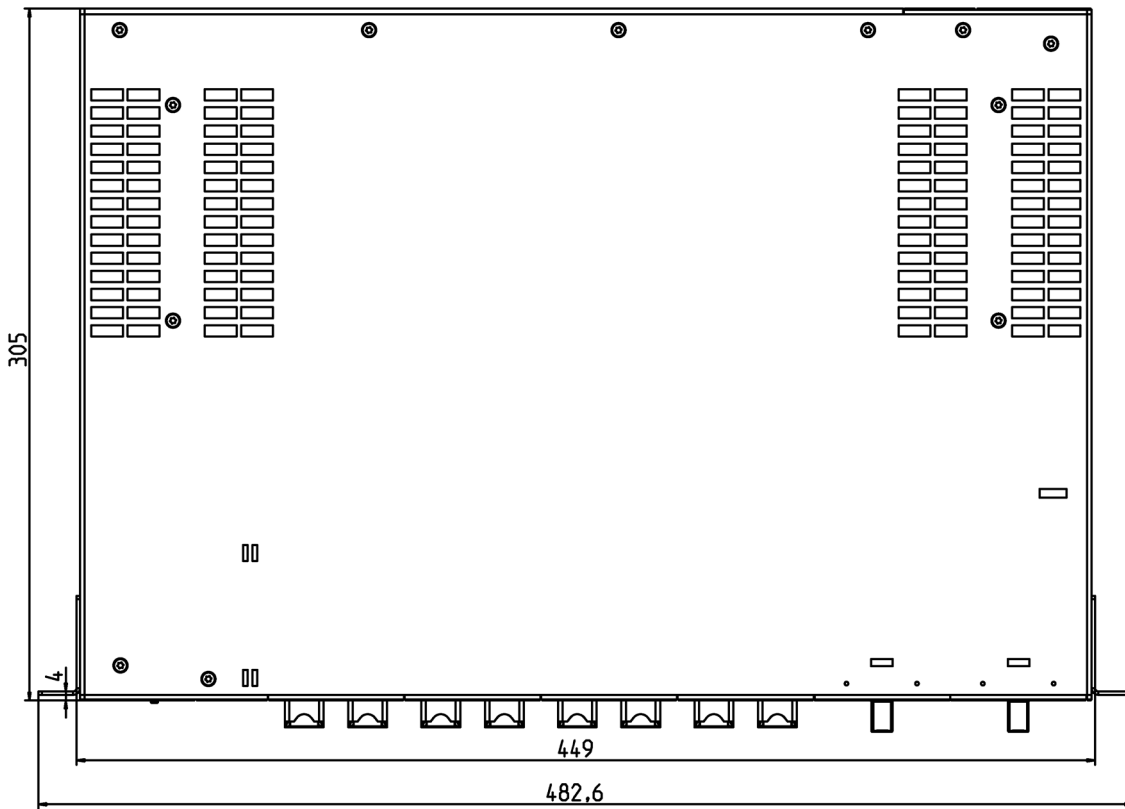

Image 11-17 Top of the housing

Mounting the IE Switch X-300EEC

 CAUTION**Making a mounting support**

Suitable mounting supports are necessary for wall mounting and 19" rack mounting. Have these made according to the drawing.

You will find other accessories, such as screws in the tables. If you have questions, contact our Customer Support.

You will also find dimension drawings on the Internet on the pages of Siemens Industry Automation Customer Support under the following entry ID:

33118441 (<http://support.automation.siemens.com/WW/view/en/33118441>)
→ "Entry list" tab

Mounting support for EEC wall mounting

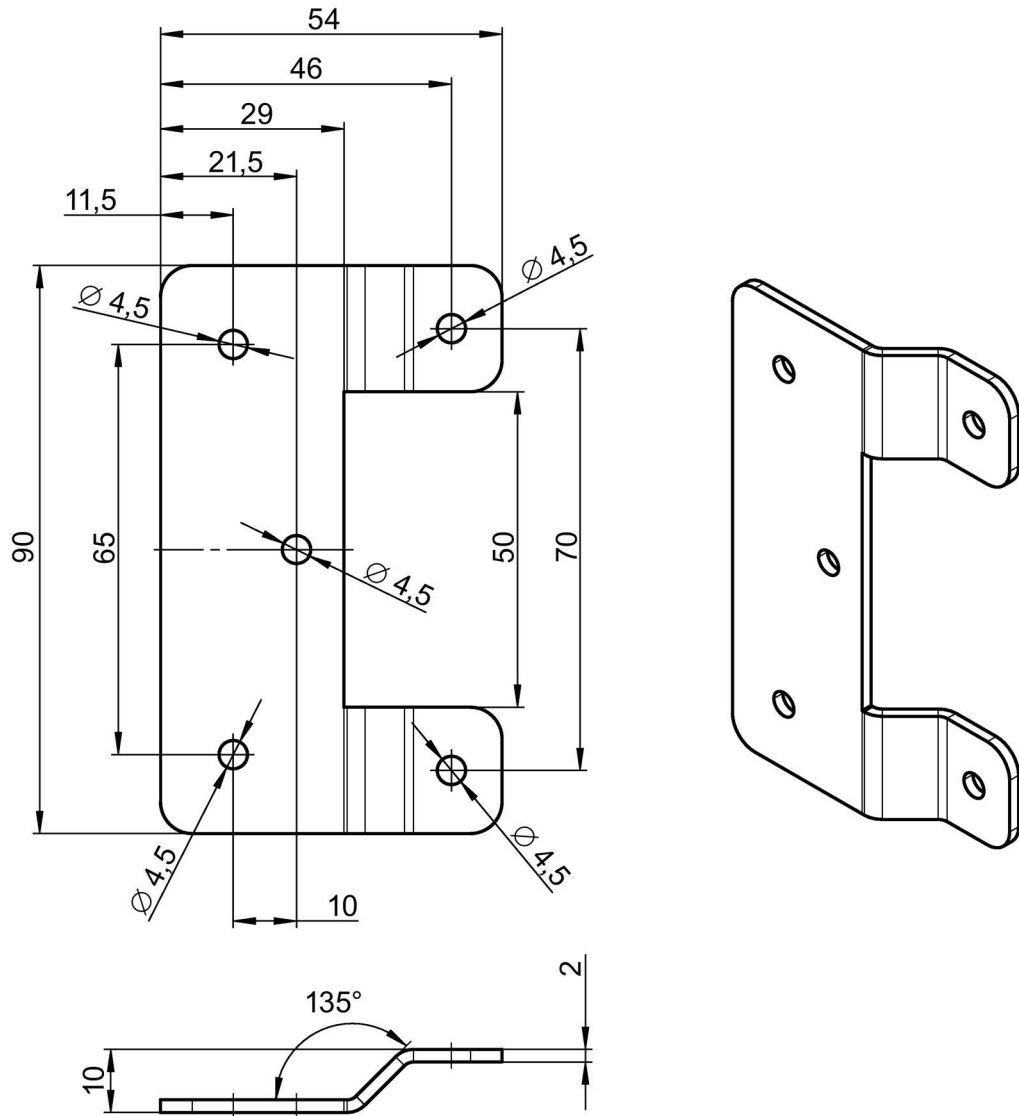

Image 11-18 X-300EEC wall mounting (dimensions in mm)

Mounting support for 19" rack mounting of the X-300EEC switch

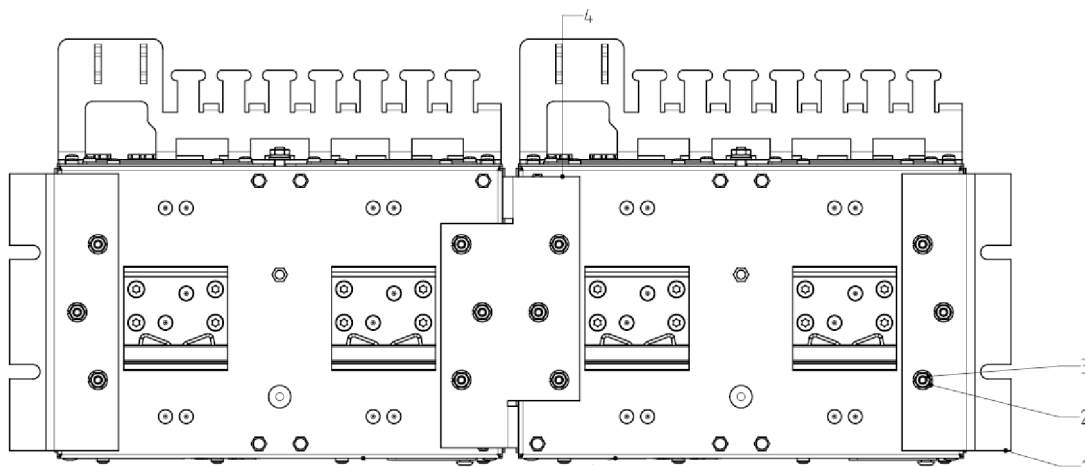

Image 11-19 Rack mounting of two X-300EECs fastened together (view from below)

Table 11- 1 Legend for rack mounting of two X-300EECs fastened together

No.	Number needed	Name
1	2	Plate for side
2	12	Spring washer SN60727-4-NrSt
3	12	Hexagonal nut ISO 4032-M4-8
4	1	Mid part of mounting support

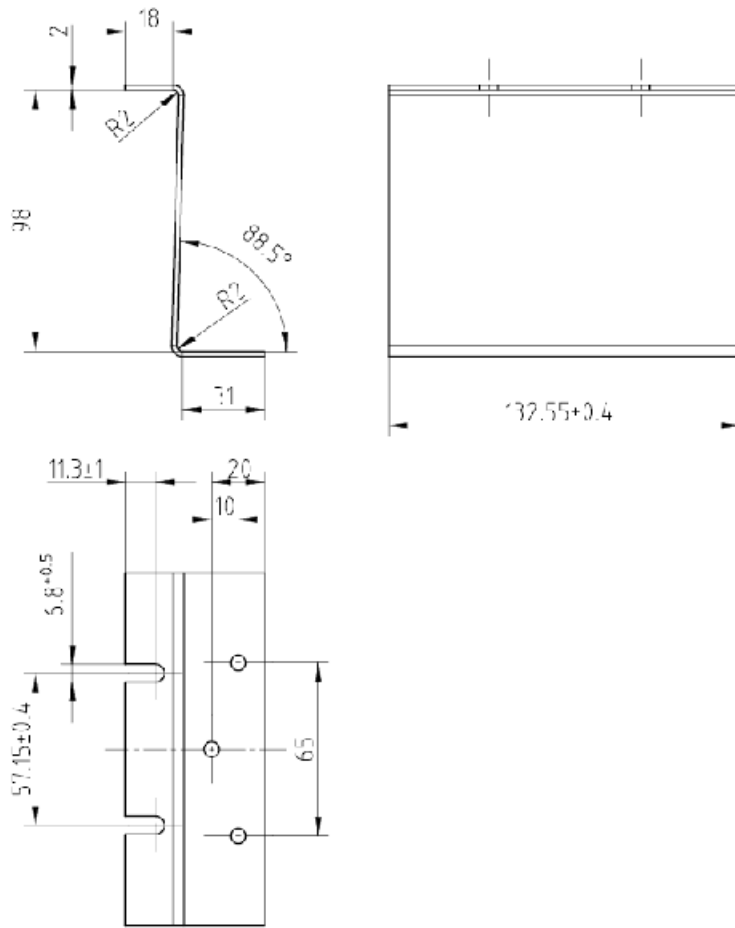

Image 11-20 Side part of mounting support for X-300EEC (dimensions in mm)

Material: Plate 2.0 DIN EN10152 DC01+ZE25/25

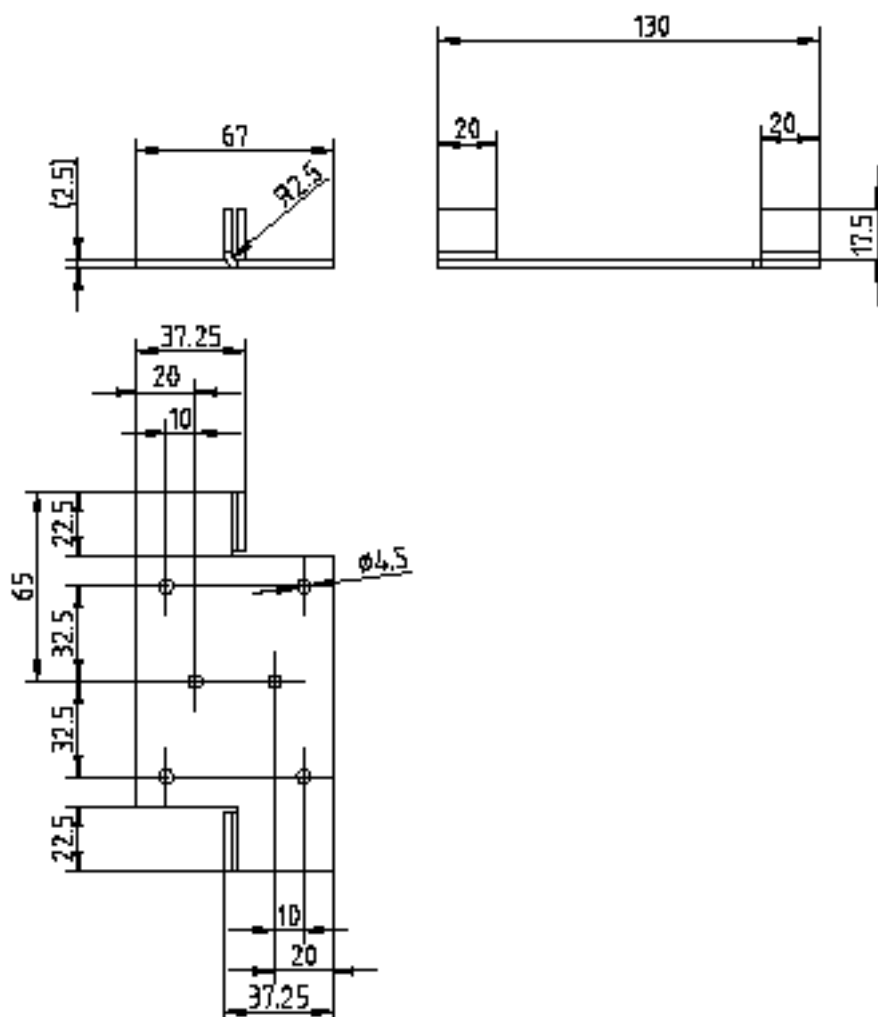

Image 11-21 Middle part of mounting support for X-300EEC (dimensions in mm)

Material: Plate 2.0 DIN EN10152 DC01+ZE25/25

See also

19" rack mounting - X-300EEC product group (Page 115)

11.6 MM900 dimension drawings

Note

The following dimension drawings are available for the **MM900** product group.

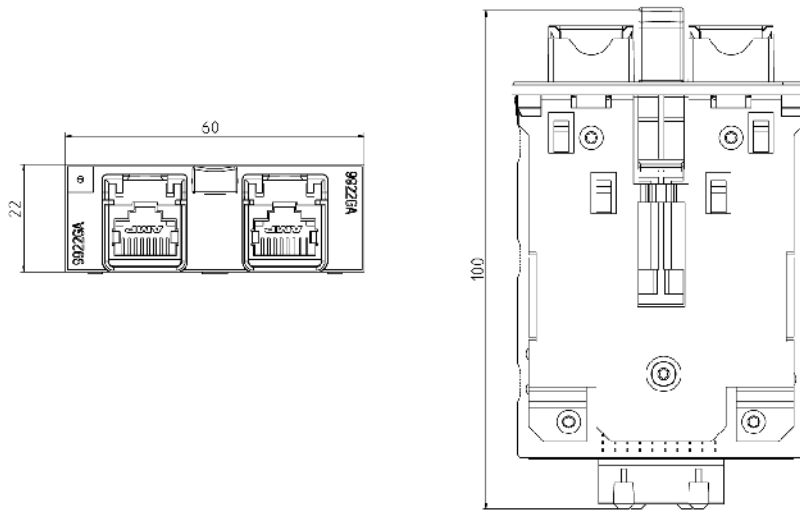

Image 11-22 MM900 dimension drawing 1: Electrical RJ-45 ports with securing collar

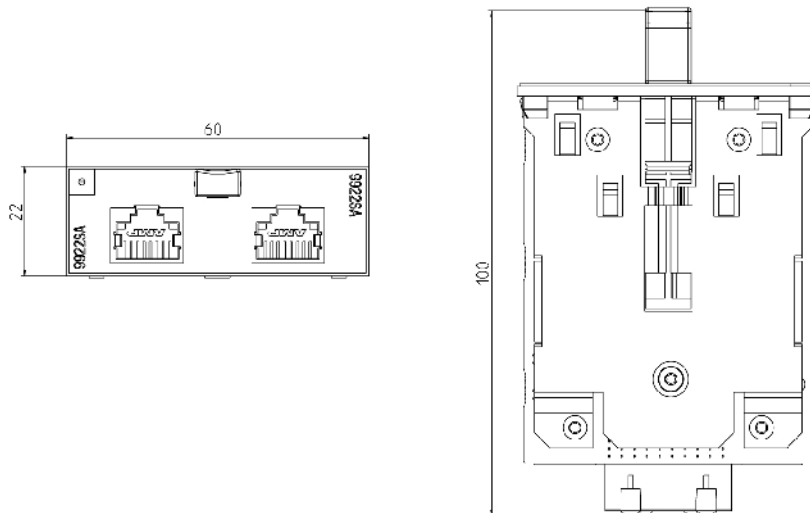

Image 11-23 MM900 dimension drawing 2: Electrical RJ-45 ports without securing collar

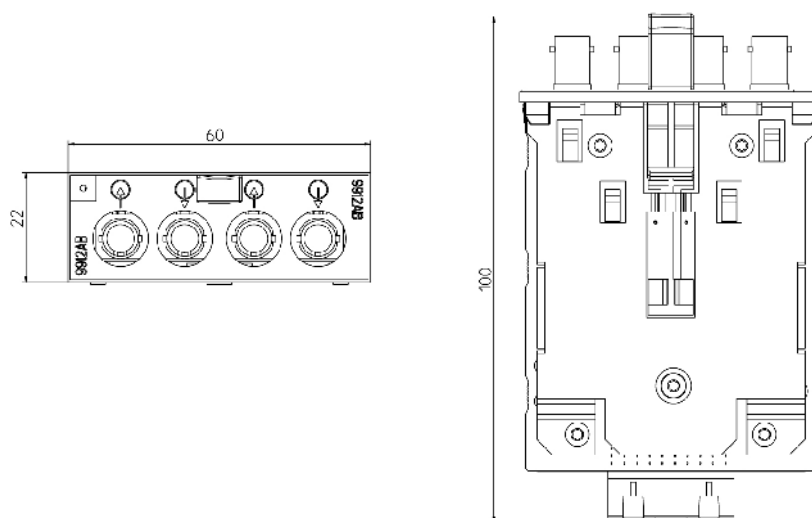

Image 11-24 MM900 dimension drawing 3: BFOC ports

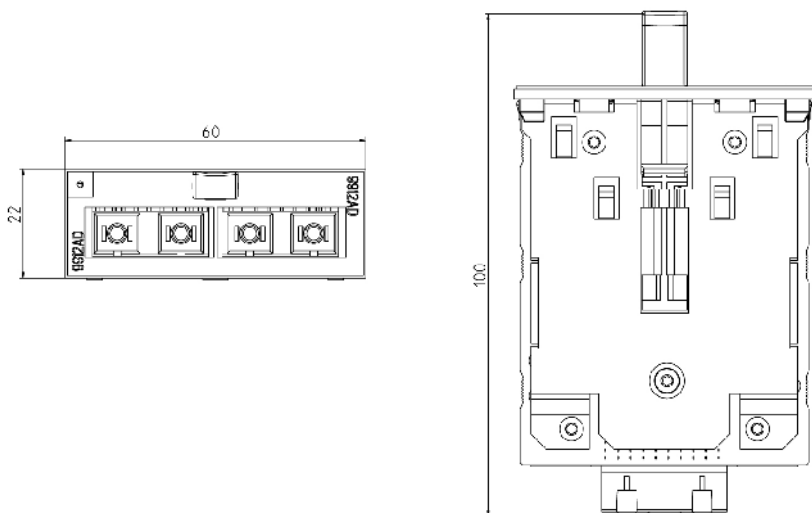

Image 11-25 MM900 dimension drawing 4: Optical SC ports

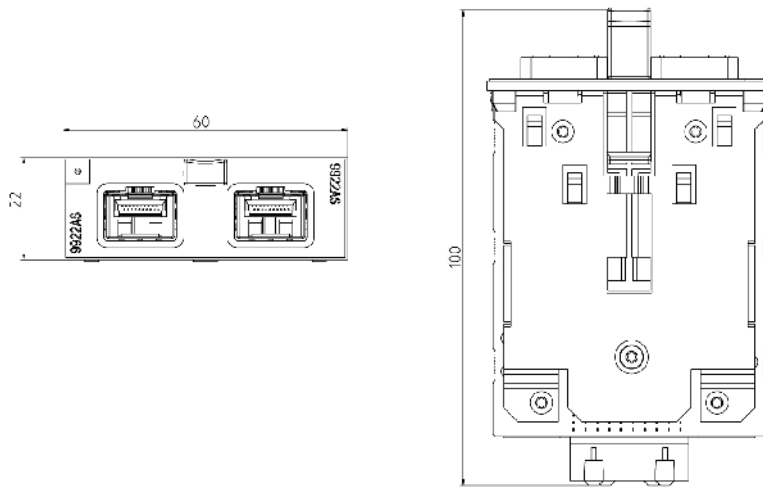

Image 11-26 MM900 dimension drawing 5: SFP media module

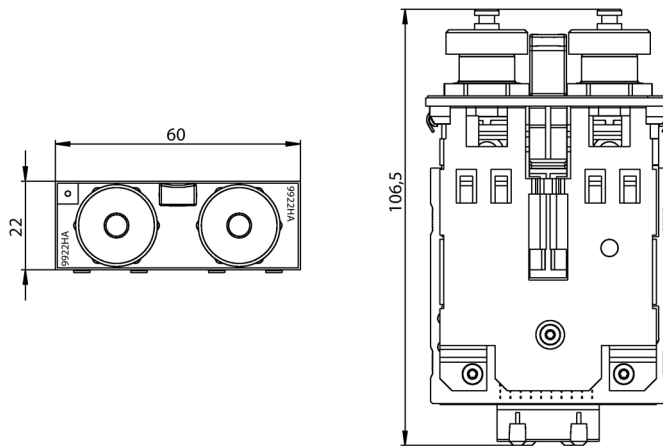

Image 11-27 MM900 dimension drawing 6: M12 ports electrical

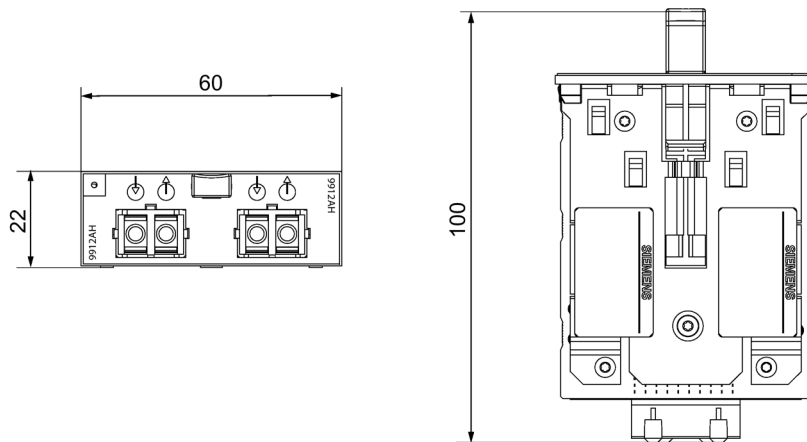

Image 11-28 MM900 dimension drawing 7: SC RJ ports optical

11.7 SFP dimension drawings

Note

The following dimension drawings are available for the **SFP** product group.

Note

All dimensions are ± 0.2 mm unless otherwise specified.

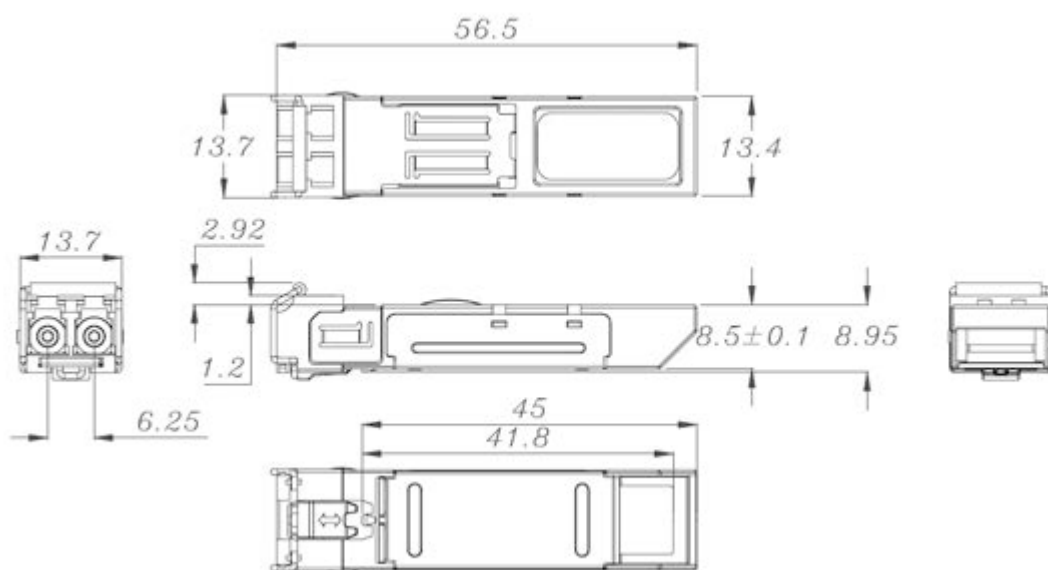

Image 11-29 SFP dimension drawing

11.8 X-300M PoE dimension drawings

All dimensions in the drawings are in millimeters.

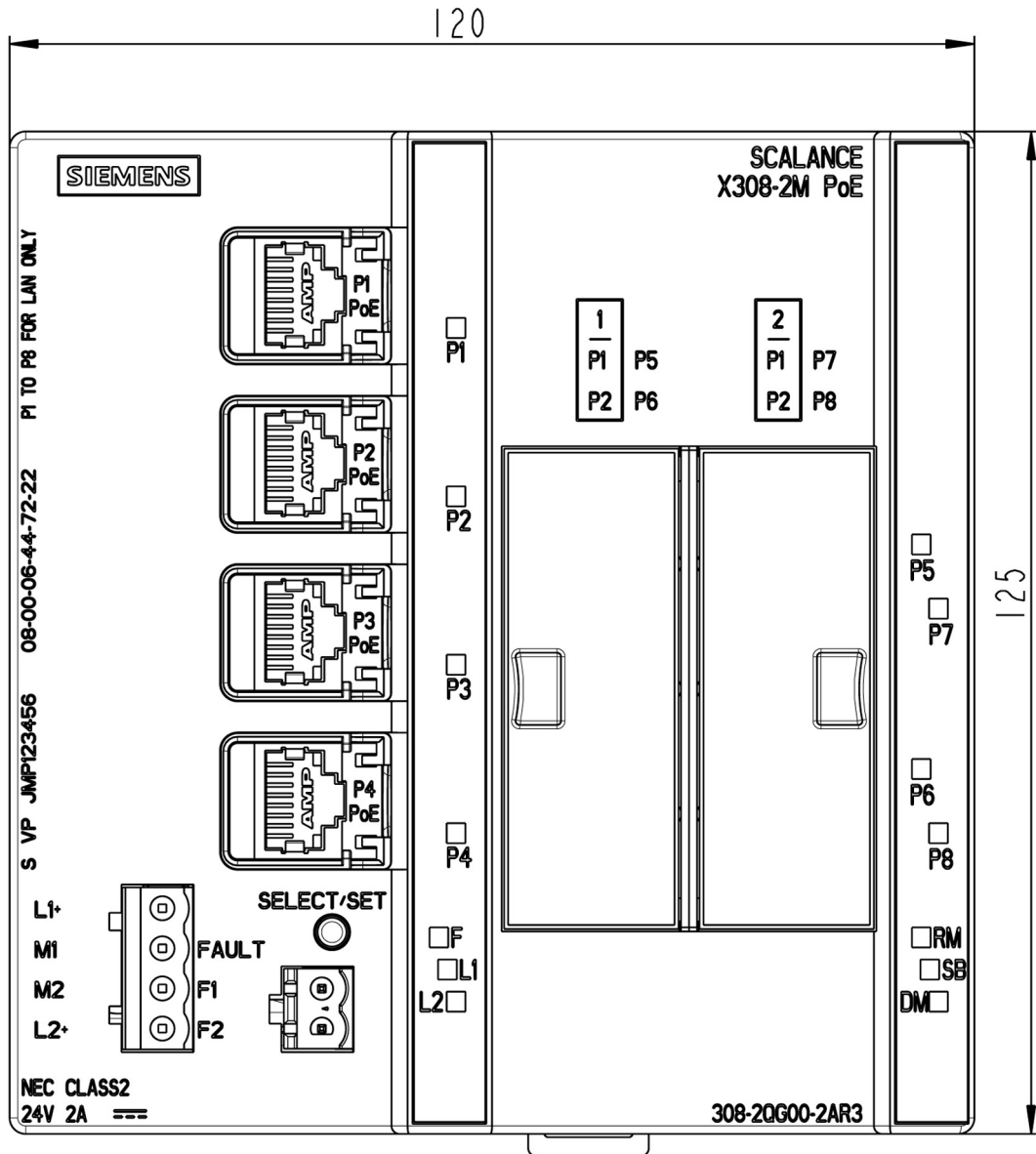

Image 11-30 X308-2M PoE: Front view

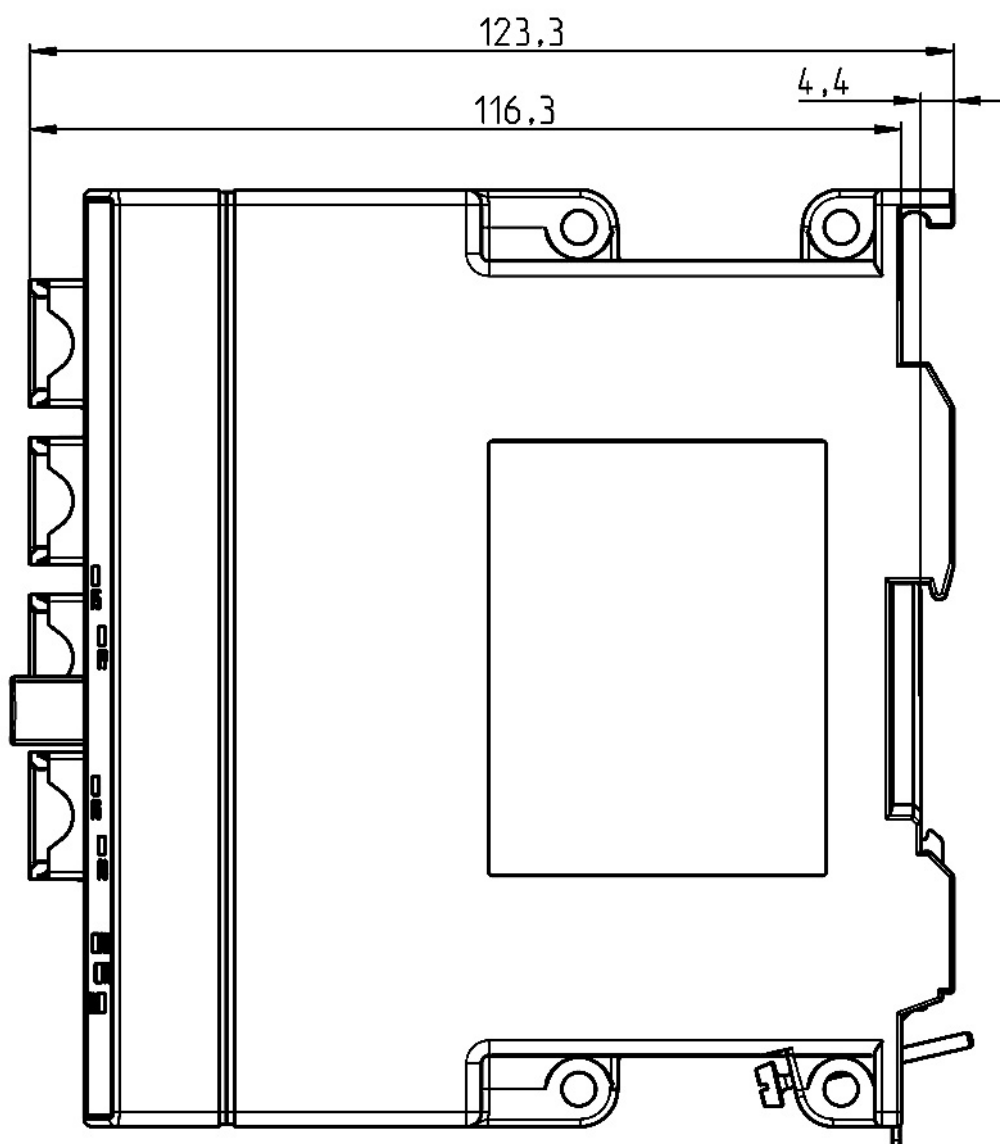

Image 11-31 X308-2M PoE: Side view

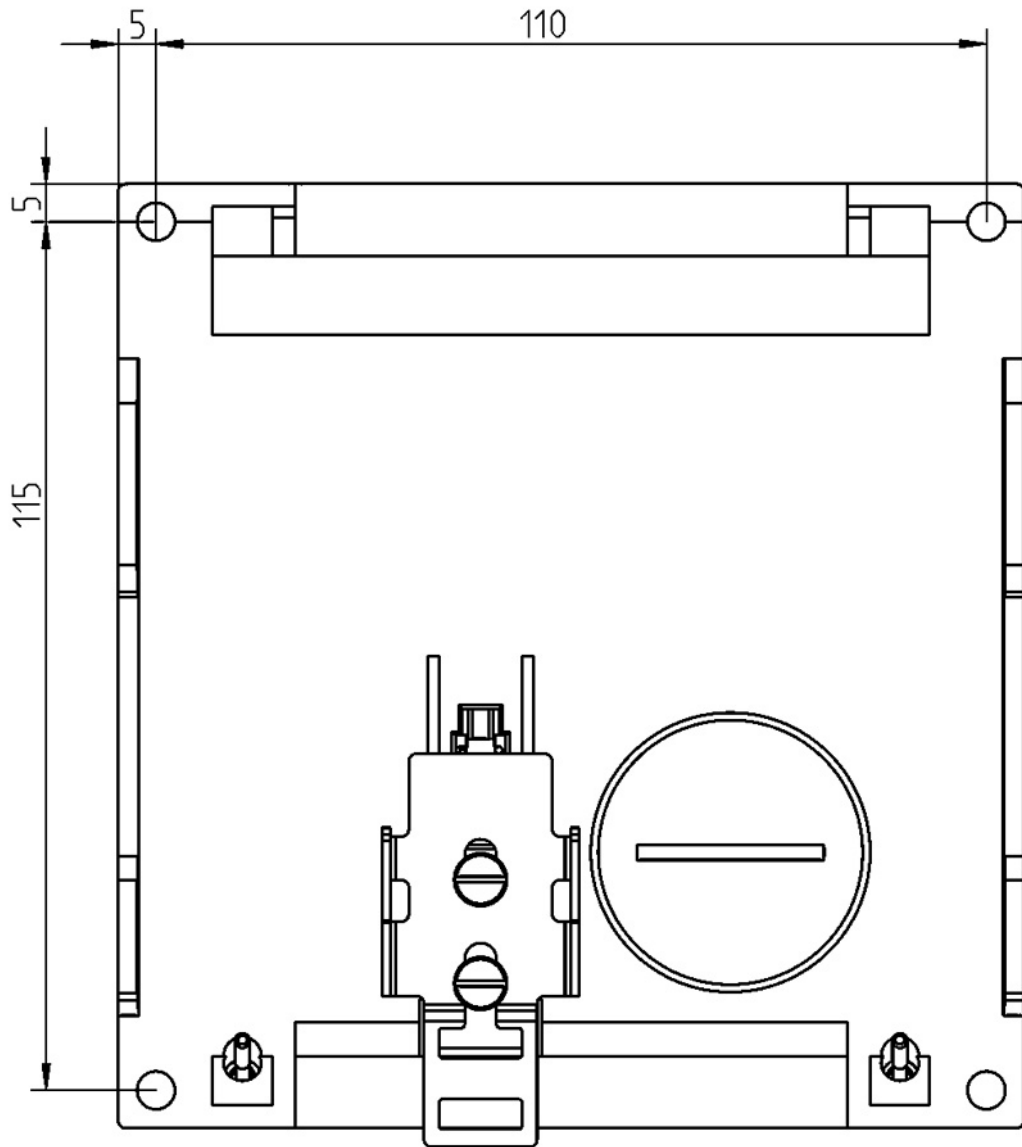

Image 11-32 X308-2M PoE: Drilling template

11.9 XR-300M PoE dimension drawings

All dimensions in the drawings are in millimeters.

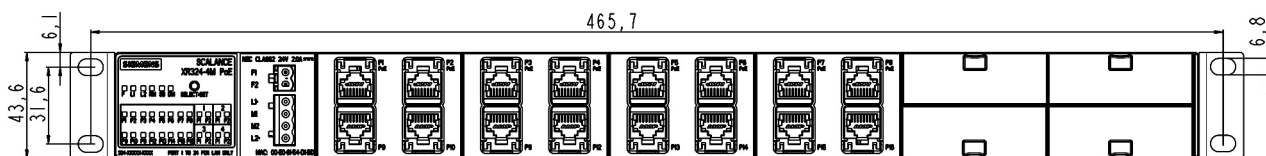

Image 11-33 XR324-4M PoE and XR324-4M PoE TS: Front view

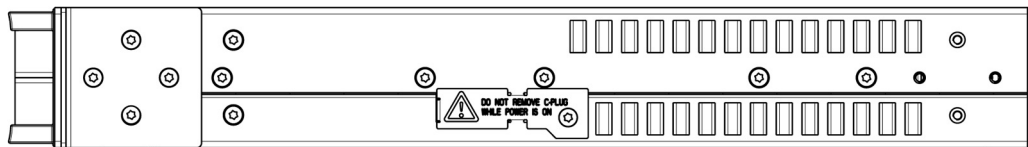

Image 11-34 XR324-4M PoE and XR324-4M PoE TS: Side view

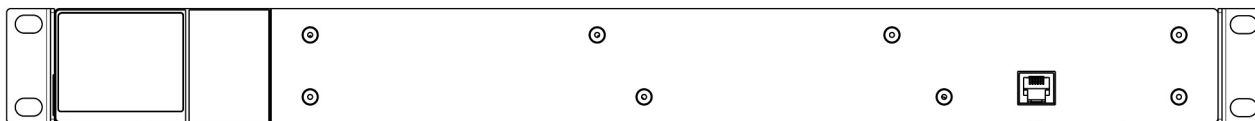

Image 11-35 XR324-4M PoE and XR324-4M PoE TS: Rear

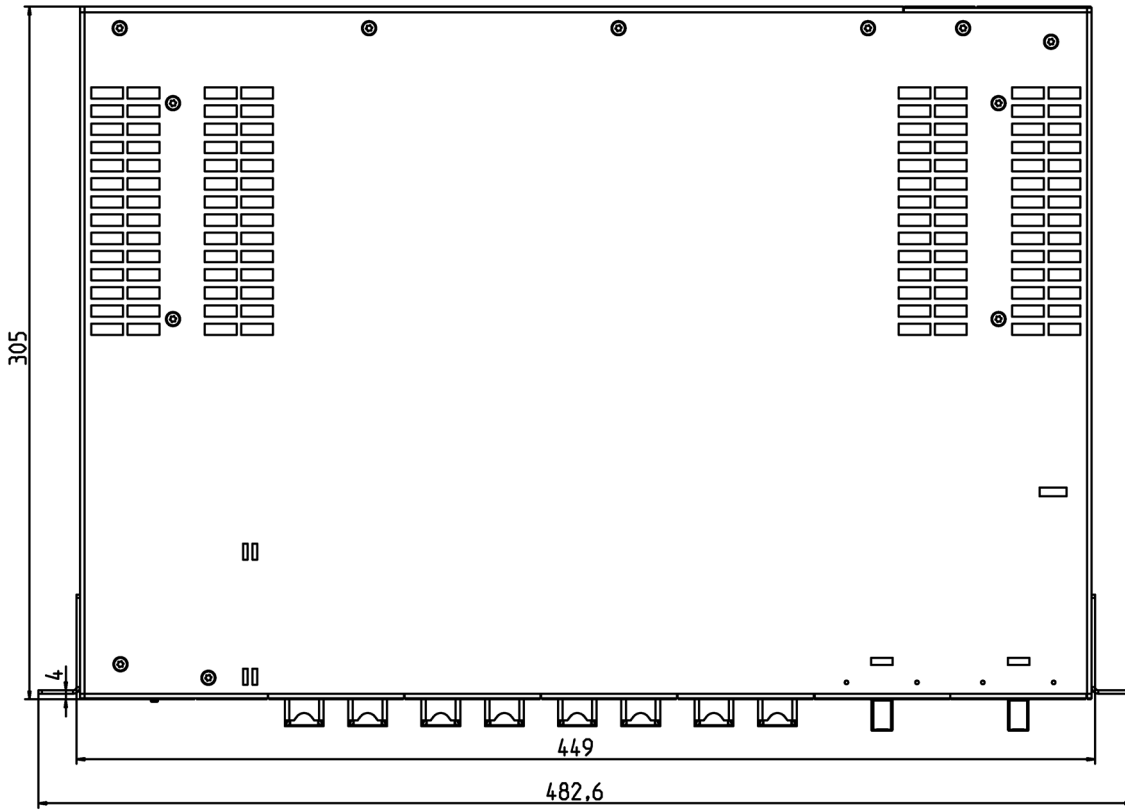

Image 11-36 XR324-4M PoE and XR324-4M PoE TS: From above

Appendix

A.1 TP port

Connector pinout

On the IE Switch X-300, the TP ports are implemented as RJ-45 jacks with MDI-X assignment (Medium Dependent Interface–Autocrossover) of a network component.

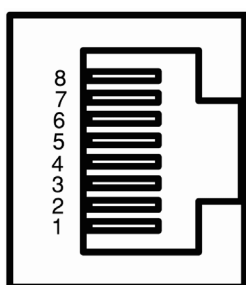

Image A-1 RJ-45 jack

Table A- 1 Pin assignment

Pin number	Pinning of the Fast Ethernet ports of IE-Switches X-300 (P1-P7) Except: SCALANCE X310FE (P1-P10)	Pinning of the gigabit Ethernet ports on SCALANCE X310 (P8 - P10) on SCALANCE X308-2, X308-2LD, X308-2LH, X308-2LH+ (P8)
Pin 8	n. c.	3-
Pin 7	n. c.	3+
Pin 6	TD-	1-
Pin 5	n. c.	2-
Pin 4	n. c.	2+
Pin 3	TD+	1+
Pin 2	RD-	0-
Pin 1	RD+	0+

Note

TP cords or TP-XP cords with a maximum length of 10 m can be connected to the RJ-45 TP port.

With the IE FC cables and IE FC RJ-45 plug, an overall cable length of up to 100 m is permitted between two devices depending on the cable type.

Autonegotiation

Autonegotiation means the automatic detection of the functionality of the port at the opposite end. Using autonegotiation, network components or end devices can detect the functionality available at the port of a partner device allowing automatic configuration of different types of device. With autonegotiation, two components connected to a link segment can exchange parameters and set themselves to match the supported communication functionality.

Note

With devices that do not support autonegotiation, the IE Switch X-300 port must be set manually to the speed and duplexity settings of the device (in other words, the identical setting).

Note

The IE Switch X-300 is a plug-and-play device that does not require settings to be made for commissioning.

MDI /MDIX autocrossover function

The advantage of the MDI /MDIX autocrossover function is that straight-through cables can be used throughout and crossover Ethernet cables are unnecessary. This prevents malfunctions resulting from mismatching send and receive wires. This makes installation much easier for the user.

The IE Switches X-300 all support the MDI / MDIX autocrossover function.

Note

Autocrossover works only in autonegotiation is enabled. If the setting is fixed, there is no autocrossover (see Glossary).

Note

Please note that a direct connection between two ports on the IE Switch X-300 or an accidental connection over several IE Switches X-300 can cause illegal formation of loops unless RSTP or STP is activated. Such a loop can lead to network overload and network failures.

A.2 The connector system M12/X coded according to IEC 61076-2-109

Description

M12 connectors with X coding are also suitable for transmission rates up to 210 Gbps (Cat6A) because the shields of the wire pairs can be led into the connectors. A further advantage is the availability of connectors with degree of protection IP67 with which the equipped devices are also suitable for adverse environmental conditions (dust, dampness). Due to the locking technology standardized for the M12 connectors a high resistance to vibration is achieved. Numerous SCALANCE devices therefore provide connection options for X coded M12 connectors.

Pin assignment

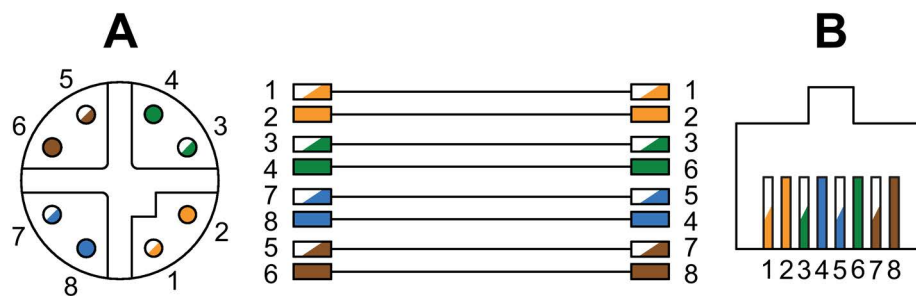

A Front view of M12 connector, X coded according to IEC61076-2-109

B Front view of RJ-45 connector, latching nose at the top, with pin assignment according to EIA/TIA 568B

Pin	M12/X coded		RJ-45 according to EIA/TIA 568B	
	Wire color	Signal	Wire color	Signal
1	White / orange	TX+	White / orange	TX+
2	Orange	TX-	Orange	TX-
3	White / green	RX+	White / green	RX+
4	Green	RX-	Blue	
5	White / brown		White / blue	
6	Brown		Green	RX-
7	White / blue		White / brown	
8	Blue		Brown	

A.3 Fitting the IE FC RJ-45 Plug

Assembly of the IE FC RJ-45 Plug on an IE FC Standard Cable

For information on assembling an IE FC RJ-45 Plug on a SIMATIC NET Industrial Ethernet FastConnect cable, please refer to the instructions supplied with the IE FC RJ-45 Plug.

Inserting the IE FC RJ-45 Plug

1. Insert the IE FC RJ-45 Plug in the twisted-pair interface of the IE switch until it locks in place.



Image A-2 Inserting the IE FC RJ-45 Plug (based on the example of the IE FC RJ-45 Plug 180)

The flush fit and locking mechanism of the PROFINET-compliant IE FC RJ-45 Plug along with the securing collar on the TP port of the IE Switch guarantee a robust connection suitable for industrial conditions providing tensile and bending strain relief for the inserted connector.

The RJ-45 interface of the IE Switch X-300EEC is fitted with a securing bracket instead of a securing collar. To increase mechanical stability, you can secure the IE FC RJ-45 PLUG to this securing bracket with a cable binder.

Removing the IE FC RJ-45 Plug

1. Press on the locking lever of the IE FC RJ-45 Plug gently to remove the plug.



Image A-3 Releasing the RJ-45 plug (based on the example of the IE FC RJ-45 Plug 180)

If there is not enough space to release the lock with your hand, you can also use a 2.5 mm screwdriver. You can then remove the IE FC RJ-45 Plug from the twisted pair socket.



Image A-4 Releasing the RJ-45 plug with a screwdriver (based on the example of the IE FC RJ-45 Plug 180)

A.4 Electrical tests (EEC devices)

Regulations / standards

- IEC 60255 (product standards)
- IEEE C37.90.0/1/2
- UL 508

Further standards: See individual tests.

Insulation test

Relevant standards: IEC 60255-5 and IEC 60870-2-1

Voltage test (routine test) for all circuits except communications and time synchronization interfaces 2.5 kV (eff) 50 Hz / 3.5 kV DC

Voltage test (routine test) only for protected communications interfaces 500 V (eff) 50 Hz / 707 V DC

Voltage test (routine test) for all circuits except communications interfaces, class III 5 kV (peak); 1.2/50 µs; 0.5 J

EMC tests of immunity (type tests)

Relevant standards: IEC 60255-6 and -22 (product standards), EN 61000-6-2 (generic standard)

High frequency test IEC 60255-22-1, class III / IEEE C37.90.1, 2.5 kV (peak); 1 MHz

Discharge of static electricity IEC 60255-22-2, class IV and IEC 61000-4-2, class IV 8 kV contact discharge; 15 kV air discharge

Radiated electromagnetic field disturbance, frequency sweep IEC 60255-22-3, class III IEC 61000-4-3, class III 10 V/m; 80 MHz to 1000 MHz; 80 % AM; 1 kHz 10 V/m; 800 MHz to 960 MHz; 80 % AM; 1 kHz 20 V/m; 1.4 GHz to 2.0 GHz; 80 % AM; 1 kHz

Irradiation with RF field, single frequencies IEC 60255-22-3, IEC 61000-4-3, class III – amplitude modulated – pulse modulated 10 V/m 80/160/450/900 MHz; 80 % AM; 1 kHz

Fast transients / burst IEC 60255-22-4 and IEC 61000-4-4 and IEEE C37.90.1 class IV 4 kV

High voltage spikes (SURGE), IEC 61000-4-5 installation class 4, auxiliary voltage pulse: 1.2/50 µs common mode: 4 kV; diff. mode: 2 kV

Relay outputs, common mode: 4 kV; diff. mode: 2 kV (valid for the signaling contact 100..240 V AC/60...250 V DC)

Line conducted high frequency, amplitude modulated IEC 61000-4-6, class III 10 V; 150 kHz to 80 MHz; 80 % AM; 1 kHz

Power frequency magnetic field IEC 60255-6 IEC 61000-4-8, class IV 0.5 mT; 50 Hz, 30 A/m permanent; 300 A/m for 3 s; 50 Hz

A.5 EMC-compatible installation of electrical Industrial Ethernet or PROFIBUS cabling

Radiated electromagnetic interference IEEE Std C37.90.2 35 V/m; 80 MHz to 1000 MHz

Damped oscillatory magnetic field IEC 60694, IEC 61000-4-12 2.5 kV (peak value), polarity alternating 100 kHz, 1 MHz

EMC tests of emission (type tests)

Relevant standard: EN 61000-6-1 (generic standard)

Radiated emission on cables, only auxiliary voltage IEC-CISPR 22 150 kHz to 30 MHz limit value class A

Radiated electric field strength IEC-CISPR 22, 30 MHz to 1000 MHz limit value class A

Voltage fluctuations and flicker on the power supply cable at 230 VAC IEC 61000-3-3; limit values kept to.

A.5 EMC-compatible installation of electrical Industrial Ethernet or PROFIBUS cabling

The Industrial Ethernet / PROFINET system manual "Passive network components" prescribes the use of fiber-optic cables for cabling between buildings and/or external facilities because there may be large potential differences between nodes.

If IE FC or PROFIBUS FC cables are used for such applications, the same rules apply as when installing cables indoors.

The following also applies:

- Install cables on metal cable racks
- Electrically connect the cable racks where they join
- Ground the cable racks
- Connect the shields of the cables to the grounding network as close as possible to the point of entry into the building or facility.
- Electrical bus cables installed outside buildings must be included in the lightning protection and grounding concept of the entire system. Follow the instructions in Appendix B "Lightning and Surge Voltage Protection for LAN Cables Between Buildings" of the SIMATIC NET PROFIBUS Networks manual.
- All SIMATIC NET PROFIBUS cables can be used if they are installed in cable channels protected against dampness. The safety clearances specified in Appendix C.7 "Cable categories and clearances" of the SIMATIC NET PROFIBUS Network Manual must then be adhered to.

A.6 Equipotential bonding

When do potential differences occur?

Potential differences can, for example, be caused by different power supplies. Potential differences between separate parts of the plant can be damaging to the system in the following situations:

- Programmable controllers and peripheral devices are linked on grounded connections
- Cable shields are contacted at both ends and grounded to different parts of the plant.

How do you avoid potential differences?

Potential differences must be reduced by installing bonding conductors so that the functions of the electronic components used are guaranteed.

When and why is equipotential bonding necessary?

Several good reasons for equipotential bonding are listed below:

- Devices with a grounded interface can be damaged by potential differences.
- The shield of the PROFIBUS cable must not be used for equipotential bonding. This is, however, the case if parts of the system connected by the cable shield are connected to different grounding points.
- Equipotential bonding is a requirement for lightning protection.

Rule for equipotential bonding

Remember the following points about equipotential bonding systems:

- The lower the impedance of the equipotential bonding cable, the greater the effectiveness of the equipotential bonding.
- The impedance of the additional bonding conductor must not exceed 10% of the shield impedance of the bus cable.
- Make largearea contact between the bonding conductor and the PE conductor.
- Protect the bonding conductor from corrosion.
- Install the bonding conductor so that the area enclosed by the bonding conductor and signal cables is as small as possible.
- Use copper or galvanized steel for the bonding conductor
- Include metal, conductive cable channels/racks in the equipotential bonding of the building and between the individual parts of the system. The individual segments of the channels/racks must be connected together with low inductance and low resistance and connected to the building ground system as often as possible. Expansion joints and angled connections should be bridged by additional flexible grounding bands.

- The connections between the individual segments of channels must be protected from corrosion (longterm stability)
- If there are connections between sections of buildings (for example separated by expansion joints) with their own reference point for the building ground network, a bonding conductor (equivalent copper crosssectional area $\geq 10 \text{ mm}^2$) must be installed parallel to the cables. This bonding conductor is not necessary if metal, conducting cable channels/racks are used.

Note

Bonding conductors are unnecessary if the sections of a system are connected exclusively using fiberoptic cable (FO).

Notes on systems in which no equipotential bonding is possible

To ensure greater immunity to interference, cables for SIMATIC NET PROFINET and PROFIBUS are always shielded. Due to the defined shielding property, the shield needs to make contact at both ends.

In systems in which no equipotential bonding is possible, the current flow via the shield needs to be prevented. Despite this, to be able to use the shield properties of the cable note the following:

- Contact the shield at one end with low resistance.
- Connect the other end of the shield to the grounding system using capacitive coupling.

Index

A

Article number, 34, 34
Attenuation, 213
Attenuator, 213
Autonegotiation, 89, 312

B

BA - Operating Instructions, 4
BAK - Operating Instructions (compact), 4

C

Communication modes, 89
Compact devices, 28
Compatibility list, 47
Connector pinout
 IE Switch X-300, 311
C-PLUG, 96
 changing (X-300EEC), 66

D

Designs of the switches, 28

E

Ethernet switches, 25

G

GI-PCF, 214
Glossary, 5

H

Hazardous area, 16

M

MDI /MDIX autocrossover function, 312
Modular devices (M), 28

N

Network topologies, 26
 Linear structure, 26, 39
 Redundant coupling of two network segments, 44
 Ring with redundancy manager, 41
 Star structure, 40
Node localization, 148

P

PH - Configuration Manual, 4
Possible attachments
 SCALANCE 307-3LD, 52
 SCALANCE 308-2LH+, 54
 SCALANCE 308-2M, 61
 SCALANCE X302-7, 65
 SCALANCE X306-1LD FE, 50
 SCALANCE X307-3, 51
 SCALANCE X308-2, 55
 SCALANCE X308-2LD, 56
 SCALANCE X308-2LH, 53
 SCALANCE X310, 57
 SCALANCE X310FE, 58
 SCALANCE X320-1 FE, 59
 SCALANCE XR324-12M, 63
 X320-3LD FE, 60
Power supply
 Media modules, 129
 Redundancy, 142
 Transceiver, 129

R

Rack devices (R), 28
Redundancy
 Power supply, 142
Redundancy manager, 40

S

Signaling contact
 redundant, 67
SIMATIC NET glossary, 5

System

manual, 224, 230, 236, 244, 250, 256, 261, 266, 274

T

Transmission mode, 89

 Full duplex, 89

 Half duplex, 89

Transmission rate, 89