

SIEMENS

SIMATIC NET

Network components Extender for SCALANCE XM-400



Operating Instructions

<u>Introduction</u>	1
<u>Safety notices</u>	2
<u>Description of the device</u>	3
<u>Installation</u>	4
<u>Connecting up</u>	5
<u>Technical specifications</u>	6
<u>Dimension drawings</u>	7
<u>Approvals</u>	A

Legal information

Warning notice system

This manual contains notices you have to observe in order to ensure your personal safety, as well as to prevent damage to property. The notices referring to your personal safety are highlighted in the manual by a safety alert symbol, notices referring only to property damage have no safety alert symbol. These notices shown below are graded according to the degree of danger.

 DANGER
indicates that death or severe personal injury will result if proper precautions are not taken.
 WARNING
indicates that death or severe personal injury may result if proper precautions are not taken.
 CAUTION
indicates that minor personal injury can result if proper precautions are not taken.
NOTICE
indicates that property damage can result if proper precautions are not taken.

If more than one degree of danger is present, the warning notice representing the highest degree of danger will be used. A notice warning of injury to persons with a safety alert symbol may also include a warning relating to property damage.

Qualified Personnel

The product/system described in this documentation may be operated only by **personnel qualified** for the specific task in accordance with the relevant documentation, in particular its warning notices and safety instructions. Qualified personnel are those who, based on their training and experience, are capable of identifying risks and avoiding potential hazards when working with these products/systems.

Proper use of Siemens products

Note the following:

 WARNING
Siemens products may only be used for the applications described in the catalog and in the relevant technical documentation. If products and components from other manufacturers are used, these must be recommended or approved by Siemens. Proper transport, storage, installation, assembly, commissioning, operation and maintenance are required to ensure that the products operate safely and without any problems. The permissible ambient conditions must be complied with. The information in the relevant documentation must be observed.

Trademarks

All names identified by ® are registered trademarks of Siemens AG. The remaining trademarks in this publication may be trademarks whose use by third parties for their own purposes could violate the rights of the owner.

Disclaimer of Liability

We have reviewed the contents of this publication to ensure consistency with the hardware and software described. Since variance cannot be precluded entirely, we cannot guarantee full consistency. However, the information in this publication is reviewed regularly and any necessary corrections are included in subsequent editions.

Table of contents

1	Introduction	5
2	Safety notices	9
3	Description of the device	11
3.1	Product group.....	11
3.2	Product overview	12
3.3	Views.....	14
3.3.1	Device view of a PE408	14
3.3.2	Device view of a PE408PoE	15
3.3.3	Device view of a PE400-8SFP.....	16
3.4	LED display	17
3.4.1	LEDs "2" and "3"	17
3.4.2	LEDs "L1" and "L2"	18
3.4.3	Port LEDs.....	18
3.5	Power over Ethernet (PoE).....	20
4	Installation	23
4.1	Safety notices for installation	23
4.2	Types of installation	24
4.3	Installation on a DIN rail.....	25
4.4	Installation on a standard S7-300 rail	27
4.5	Installation on a standard S7-1500 rail	28
4.6	Fitting an extender	29
5	Connecting up	33
5.1	Safety when connecting up.....	33
5.2	PoE power supply of the PE408PoE	34
6	Technical specifications	37
6.1	PE408	37
6.2	PE408PoE.....	38
6.3	PE400-8SFP	39
7	Dimension drawings	41
A	Approvals	45
	Index	49

Introduction

Purpose of the Operating Instructions

These operating instructions support you when installing and connecting extenders within the SCALANCE XM-400 product group.

The configuration and the integration of the device in a network are not described in these operating instructions.

Validity of the Operating Instructions

These operating instructions apply to the following devices:

- Port extender PE408
- Port extender PE408PoE
- Port extender PE400-8SFP

Unless mentioned otherwise, the descriptions in these operating instructions refer to all devices named in the section on validity.

Designations used

Classification	Description	Terms used
Product line	The product line includes all devices and variants of all product groups. If information applies to all product groups within the product line, the term X-400 is used.	X-400
Product group	If information applies to all devices and variants of a product group, the term PE400 is used.	PE400
Device	If information relates to a specific device, the device name is used.	PE408 PE408PoE PE400-8SFP

Additional documentation

Note

When handling PE400 port extenders, you should also take into account the operating instructions of the SCALANCE XM-400 basic devices.

The operating instructions of the SCALANCE XM-400 basic devices can be found:

- on the data medium that ships with some products:
 - Product CD / product DVD
 - SIMATIC NET Manual Collection
- on the Internet pages of Siemens Industry Online Support under the following entry ID: 79722042 (<http://support.automation.siemens.com/WW/view/en/79722042>)

Further documentation

In the system manuals "Industrial Ethernet / PROFINET Industrial Ethernet" and "Industrial Ethernet / PROFINET passive network components", you will find information on other SIMATIC NET products that you can operate along with the devices of this product line in an Industrial Ethernet network.

There, you will find among other things optical performance data of the communications partner that you require for the installation.

You will find the system manuals here:

- On the data medium that ships with some products:
 - Product CD / product DVD
 - SIMATIC NET Manual Collection
- On the Internet pages of Siemens Industry Online Support under the following entry IDs:
 - 27069465 (<http://support.automation.siemens.com/WW/view/en/27069465>)
Industrial Ethernet / PROFINET Industrial Ethernet System Manual
 - 84922825 (<http://support.automation.siemens.com/WW/view/en/84922825>)
Industrial Ethernet / PROFINET - Passive network components System Manual

SIMATIC NET manuals

You will find SIMATIC NET manuals on the Internet pages of Siemens Industry Online Support:

- using the search function:

Link to Siemens Industry Online Support
(<http://support.automation.siemens.com/WW/view/en>)

Enter the entry ID of the relevant manual as the search item.

- In the navigation panel on the left hand side in the area "Industrial Communication":

Link to the area "Industrial Communication"
(<http://support.automation.siemens.com/WW/view/en/10805878/130000>)

Go to the required product group and make the following settings:
tab "Entry list", Entry type "Manuals"

You will find the documentation for the SIMATIC NET products relevant here on the data medium that ships with some products:

- Product CD / product DVD
- SIMATIC NET Manual Collection

SIMATIC NET glossary

Explanations of many of the specialist terms used in this documentation can be found in the SIMATIC NET glossary.

You will find the SIMATIC NET glossary here:

- SIMATIC NET Manual Collection or product DVD

The DVD ships with certain SIMATIC NET products.

- On the Internet under the following entry ID:

50305045 (<http://support.automation.siemens.com/WW/view/en/50305045>)

Catalogs

You will find the order numbers for the Siemens products of relevance here in the following catalogs:

- SIMATIC NET Industrial Communication / Industrial Identification, catalog IK PI
- SIMATIC Products for Totally Integrated Automation and Micro Automation, catalog ST 70
- Industry Mall - catalog and ordering system for automation and drive technology, Online catalog
(<https://eb.automation.siemens.com/goos/WelcomePage.aspx?regionUrl=/en&language=en>)

You can request the catalogs and additional information from your Siemens representative.

Unpacking and checking

 WARNING
Do not use any parts that show evidence of damage
If you use damaged parts, there is no guarantee that the device will function according to the specification.
If you use damaged parts, this can lead to the following problems:
<ul style="list-style-type: none">• Injury to persons• Loss of the approvals• Violation of the EMC regulations• Damage to the device and other components
Use only undamaged parts.

1. Make sure that the package is complete.
2. Check all the parts for transport damage.

Security information

Siemens provides products and solutions with industrial security functions that support the secure operation of plants, solutions, machines, equipment and/or networks. They are important components in a holistic industrial security concept. With this in mind, Siemens' products and solutions undergo continuous development. Siemens recommends strongly that you regularly check for product updates.

For the secure operation of Siemens products and solutions, it is necessary to take suitable preventive action (e.g. cell protection concept) and integrate each component into a holistic, state-of-the-art industrial security concept. Third-party products that may be in use should also be considered. For more information about industrial security, visit <http://www.siemens.com/industrialsecurity>.

To stay informed about product updates as they occur, sign up for a product-specific newsletter. For more information, visit <http://support.automation.siemens.com>.

Safety notices

Read the safety notices

Note the following safety notices. These relate to the entire working life of the device.

You should also read the safety notices relating to handling in the individual sections, particularly in the sections "Installation" and "Connecting up".

Safety notices on use in hazardous areas

General safety notices relating to protection against explosion

 WARNING
EXPLOSION HAZARD
DO NOT OPEN WHEN ENERGIZED.

Safety notices when using the device according to Hazardous Locations (HazLoc)

If you use the device under HazLoc conditions you must also keep to the following safety notices in addition to the general safety notices for protection against explosion:

This equipment is suitable for use in Class I, Division 2, Groups A, B, C and D or non-hazardous locations only.

This equipment is suitable for use in Class I, Zone 2, Group IIC or non-hazardous locations only.

Description of the device

3.1 Product group

SCALANCE XM-400 product group

The product group SCALANCE XM-400 consists of basic devices (compact switches) and extenders (port extenders).

SCALANCE XM-400 basic device

Basic properties

The SCALANCE XM-400 basic devices are modular compact switches with fixed RJ-45 ports (10/100/1000 Mbps) and SFP transceiver slots that can be equipped individually. The SFP transceiver slots are combo ports.

A SCALANCE XM-400 can manage a maximum of 24 ports with 10/100/1000 Mbps.

The following components exist only on the basic device:

- CPU
- Power supply
- Signaling contact
- Out-of-band port
- Serial interface
- "SELECT / SET" button

Expansions

The basic devices can be expanded with additional ports by using an extender. The extenders are connected to the side of the basic device. Each basic device has an expansion interface on the right for port extenders.

Depending on the number of ports of the basic device (10/100/1000 Mbps) up to 2 port extenders can be added. Further port extenders are not supplied with power. There is no particular order in which the port extenders need to be added.

Example

- The basic device SCALANCE XM408-8C has 8 ports. It can therefore be expanded by 2 port extenders each with 8 ports.
- The basic device SCALANCE XM416-4C has 16 ports. It can therefore be expanded by one port extender with 8 ports.

Port extender (PE400)

Port extenders are modular network components with RJ-45 ports (10/100/1000 Mbps) or SFP transceiver slots. To the left they have an expansion interface to connect to the basic device or to another port extender and to the right they have an expansion interface for additional port extenders. Each port extender functions with every basic device.

Note

Port extenders function only in conjunction with a basic device.

3.2 Product overview

Port extender

Device	Property	Order number
PE408	8 x 10/100/1000 Mbps RJ-45 ports	6GK5 408-0GA00-8AP2
PE408PoE	8 x 10/100/1000 Mbps, RJ-45 ports with PoE	6GK5 408-0PA00-8AP2
PE400-8SFP	8 x 100/1000 Mbps, SFP ports	6GK5 400-8AS00-8AP2

Type designation

The type designation of an extender is made up of several parts that have the following meaning:

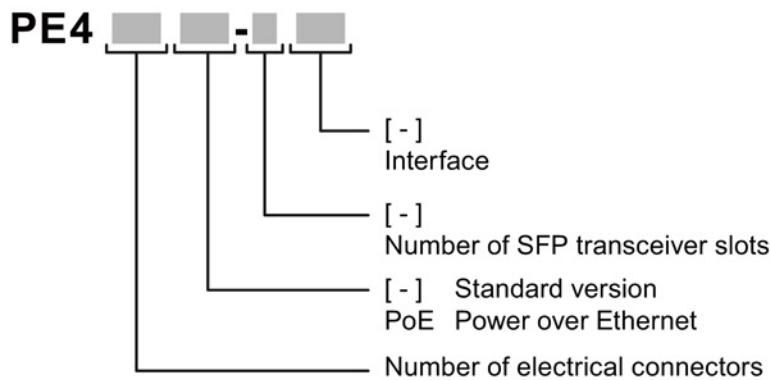

Interface	Property
SFP	SFP port with 100/1000 Mbps

Components of the product

The following components are supplied with every extender:

- One device
- Operating Instructions (compact)
- Securing screw for mounting on an S7 standard rail

The following components are also supplied with a PE408PoE:

- Two 2-pin terminal blocks for Power over Ethernet (spring-loaded terminal)

Pluggable transceiver

The following SFP transceivers can be used for the port extender:

Pluggable transceiver	Property	Order number
SFP991-1	1 x 100 Mbps, LC port optical for glass FO cable (multimode), up to max. 5 km	6GK5 991-1AD00-8AA0
SFP991-1LD	1 x 100 Mbps LC port optical for glass FO cable (single mode) up to max. 26 km	6GK5 991-1AF00-8AA0
SFP992-1	1 x 1000 Mbps, LC port optical for glass FO cable (multimode), up to max. 750 m	6GK5 992-1AL00-8AA0
SFP992-1LD	1 x 1000 Mbps LC port optical for glass FO cable (single mode) up to max. 10 km	6GK5 992-1AM00-8AA0

3.3 Views

3.3.1 Device view of a PE408

The following figure shows an overview of the components of the PE408.

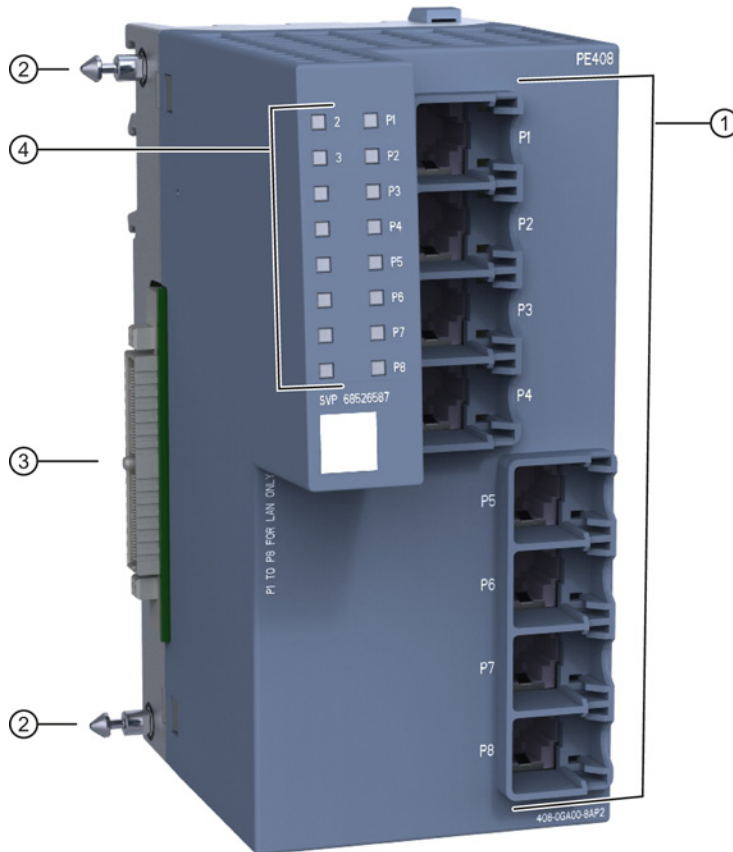

- ① Electrical ports
- ② Centering pin
- ③ Multipole connector for connection to the expansion interface
- ④ LED display

3.3.2 Device view of a PE408PoE

The following figure shows an overview of the components of the PE408PoE.

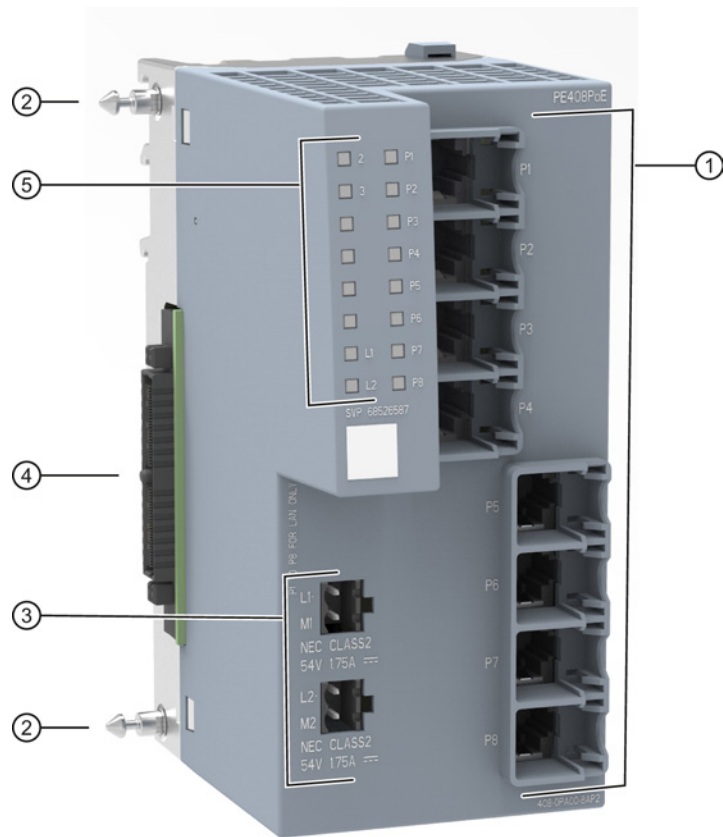

- ① Electrical ports
- ② Centering pin
- ③ Connectors for the PoE power supplies:
 - L1+/M1 for PoE supply of ports P1 to P4
 - L2+/M2 for PoE supply of ports P5 to P8
- ④ Multipole connector for connection to the expansion interface
- ⑤ LED display

3.3.3 Device view of a PE400-8SFP

The following figure shows an overview of the components of the PE400-8SFP.

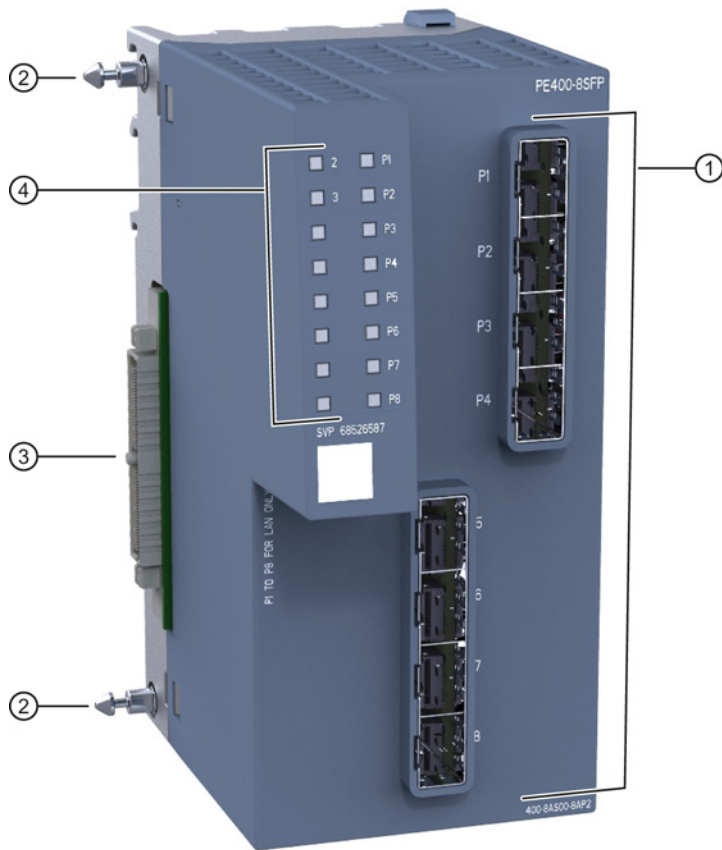

- ① Slots for SFP transceivers
- ② Centering pin
- ③ Multipole connector for connection to the expansion interface
- ④ LED display

3.4 LED display

The following figure shows the arrangement of the LEDs.

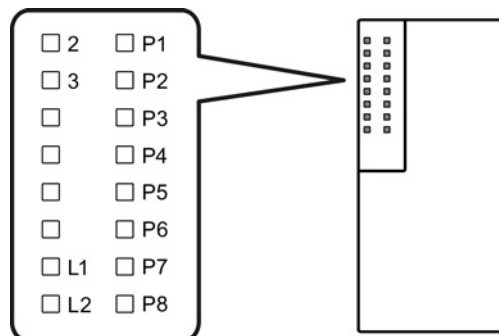

2/3 LEDs for displaying the device position
 L1/L2 LEDs for displaying the PoE power supply (PE408PoE only)
 P LEDs for displaying the port status

3.4.1 LEDs "2" and "3"

Meaning

The "2" and "3" LEDs show the position of the port extender beside the basic device.

LED	LED status	Position
2	On	The port extender is directly connected to the basic device.
3	On	There is another port extender between the basic device and the port extender.

Port name

To be able to address a specific port in Web Based Management or Command Line Interface, the ports require a unique identifier.

The port identifier is made up of the position of the device and the port number. The basic device always has position 1. With the extenders, you can read the position at LEDs "2" and "3".

Examples:

- Port 1.1
On the basic device port "P1"
- Port 2.1
On the extender on which LED "2" is lit, port "P1"
- Port 3.2
On the extender on which LED "3" is lit, port "P2"

3.4.2 LEDs "L1" and "L2"

Note

Only the port extender PE408PoE has the LEDs "L1" and "L2".

The LEDs "L1" and "L2" display information about the PoE power supply at the connectors L1+/M1 und L2+/M2.

From the "L1" and "L2" LEDs you can see whether the PoE power supply is higher or lower than 46 V.

LED L1/L2		L1/L2 connector
LED color	LED status	
-	Off	PoE power supply lower than 46 V
Green	On	PoE power supply higher than 46 V

3.4.3 Port LEDs

The port LEDs "P1", "P2" etc. show information about the corresponding ports.

The meaning of the Port LEDs depends on the display mode set on the basic device.

Meaning in display mode A

In display mode A, the port LEDs indicate whether a valid link exists.

LED color	LED status	Meaning
-	Off	No valid link to the port (for example station turned off or cable not connected).
Green	On	Link exists and port in normal status. In this status, the port can receive and send data.
	Flashes once per period*	Link exists and port in "blocking" status. In this status, the port only receives management data (no user data).
	Flashes three times per period*	Link exists and port turned off by management. In this status, no data is sent or received via the port.
	Flashes four times per period*	Link exists and is in the "monitor port" status. In this status, the data traffic of another port is mirrored to this port.
Yellow	Flashing / lit	Receiving data at port

* 1 period $\hat{=}$ 2.5 seconds

Meaning in display mode B

In display mode B, the port LEDs indicate the transmission speed.

LED color	LED status	Meaning
-	Off	Port operating at 10 Mbps
Green	On	Port operating at 100 Mbps
Orange	On	Port operating at 1000 Mbps

If there is a connection problem and the type of transmission is fixed (autonegotiation off), the desired status, in other words the set transmission speed (1000 Mbps, 100 Mbps, 10 Mbps) continues to be displayed. If there is a connection problem and autonegotiation is active, the port LED goes off.

Meaning in display mode C

In display mode C, the port LEDs indicate the mode.

LED color	LED status	Meaning
-	Off	Port operating in half duplex mode
Green	On	Port operating in full duplex mode

Meaning in display mode D

In display mode D, the port LEDs indicate whether the port is monitored.

LED color	LED status	Meaning
-	Off	Port is not monitored. If no link was established at the port the signaling contact does not indicate an error.
Green	On	Port is monitored. If no link was established at the port the signaling contact indicates an error.

Meaning in display mode E

In display mode E, the port LEDs indicate whether the connected device is supplied using PoE.

LED color	LED status	Meaning
-	Off	The connected device is not supplied using PoE.
Green	On	The connected device is supplied via PoE.

3.5 Power over Ethernet (PoE)

Function

The "Power over Ethernet" function supplies connected devices with power via the Ethernet cable. Devices supplied with power via an Ethernet cable do not require a separate voltage source.

PoE-compliant devices can be divided into the following groups:

- Power source (PSE - Power Sourcing Equipment)
These inject power onto the Ethernet cable.
- Power consumer (PD - Powered Device)
These are supplied with power via the Ethernet cable.

Port extender PE408PoE

Without connected PoE power supply

If no PoE power supply is connected, the PE408PoE functions like a PE408. It expands the basic device by 8 RJ-45 ports.

With connected PoE power supply

If a PoE power supply is connected, the PE408PoE port extender is a power source. The PE408PoE can supply devices capable of PoE with power via the Ethernet cable.

You will find notes on connecting the PoE power supply in the section "PoE power supply of the PE408PoE (Page 34)".

Note

Even when a PoE power supply is connected, you can connect devices without PoE functionality. A voltage is applied only after the port extender has detected an end device capable of PoE at the port. With devices not capable of PoE, only the data connection is used.

PoE ports of the PE408PoE

- The PoE ports of the PE408PoE comply with the standard IEEE 802.3at (type 2).
- Ports P1 to P4 are not isolated from each other. This means that they meet the conditions named in Environment A: Power supply over Ethernet within a power supply system. The same applies in the port group P5 to P8.
- Any port of the port group P1 to P4 is isolated from any port in port group P5 to P8 and therefore meets the conditions named in Environment B.
The requirement for this is the supply via two separate power supply units.
- Ports P1 to P4 are supplied with power via the PoE power supply L1+/M1. Ports P5 to P8 are supplied with power via the PoE power supply L2+/M2.
- A maximum of 90 W are available per port group.
- If you use a Cat5/Cat5e cable with a maximum length of 100 m, the connected device can be supplied with a power of 25.5 W.

Configuration

How you activate and configure PoE is described in the following configuration manuals:

- SCALANCE XM-400/XR-500 Web Based Management
- SCALANCE XM-400/XR-500 Command Line Interface

You will find the configuration manuals here:

- on the data medium that ships with some products:
 - Product CD / product DVD
 - SIMATIC NET Manual Collection
- On the Internet pages of Siemens Industry Online Support.
(<http://support.automation.siemens.com/WW/view/en/79730528/130000>)

Power supply and pin assignment

The voltage is transferred on the data wires 1, 2, 3 and 6 of the Ethernet cable.

With the RJ-45 plug, the pin pairs 1/2 are used for the negative and 3/6 for the positive power supply.

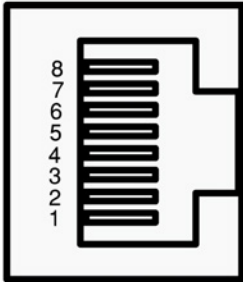

Figure 3-1 RJ-45 jack

Pin number	Assignment
Pin 8	-
Pin 7	-
Pin 6	positive power supply
Pin 5	-
Pin 4	-
Pin 3	positive power supply
Pin 2	negative power supply
Pin 1	negative power supply

Installation

4.1 Safety notices for installation

Safety notices

When installing the device, keep to the safety notices listed below.

 WARNING
If a device is operated in an ambient temperature of more than 50 °C, the temperature of the device housing may be higher than 70 °C. The device must therefore be installed so that it is only accessible to service personnel or users that are aware of the reason for restricted access and the required safety measures at an ambient temperature higher than 50 °C.

Safety notices on use in hazardous areas

General safety notices relating to protection against explosion

 WARNING
EXPLOSION HAZARD
SUBSTITUTION OF COMPONENTS MAY IMPAIR SUITABILITY FOR CLASS I, DIVISION 2 OR ZONE 2.

 WARNING
When used in hazardous environments corresponding to Class I, Division 2 or Class I, Zone 2, the device must be installed in a cabinet or a suitable enclosure.

Safety notices when using the device according to ATEX

If you use the device under ATEX conditions you must also keep to the following safety notices in addition to the general safety notices for protection against explosion:

 WARNING
To comply with EU Directive 94/9 (ATEX95), this enclosure must meet the requirements of at least IP54 in compliance with EN 60529.

 **WARNING**

If the cable or conduit entry point exceeds 70 °C or the branching point of conductors exceeds 80 °C, special precautions must be taken. If the equipment is operated in an air ambient in excess of 60 °C, only use cables with admitted maximum operating temperature of at least 80 °C.

Further notes

NOTICE

Warning and premature aging of the IE switch due to direct sunlight

Direct sunlight can heat up the device and can lead to premature aging of the IE switch and its cabling.

Provide suitable shade to protect the IE switch against direct sunlight.

4.2 Types of installation

Types of installation

You have the following options for the device:

- DIN rail
- S7-300 standard rail
- S7-1500 standard rail

4.3 Installation on a DIN rail

Installation

⚠ WARNING
Danger of injury by falling objects
The 35 mm DIN rail does not provide adequate support in shipping or when there is severe vibration (> 10 g). When used under these conditions, the device can detach itself and may cause injury to persons. When used in shipbuilding or when extreme vibration can be expected, mount the device on a S7 standard rail.

To install the device on a 35 mm DIN rail complying with DIN EN 60715, follow the steps below:

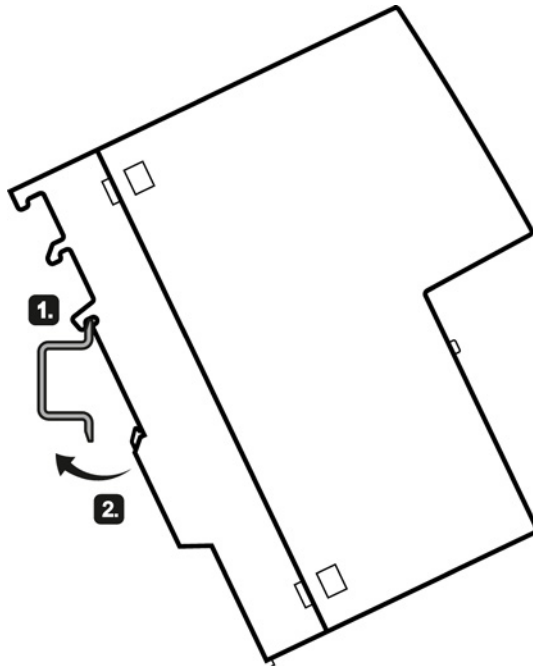

Figure 4-1 DIN rail mounting

1. Place the third housing guide of the device on the top edge of the DIN rail ①.
2. Press the device down against the DIN rail ② until the spring catch locks in place.

Removal

To remove the device from a DIN rail, follow the steps below:

1. If the extender is connected to a basic device, disconnect the extender, see section "Fitting an extender (Page 29)".
2. Release the DIN rail catch on the bottom of the device using a screwdriver.
3. Pull lower part of the device away from the DIN rail.

4.4 Installation on a standard S7-300 rail

Installing on an S7-300 standard rail

To install the device on an S7-300 standard rail, follow the steps below:

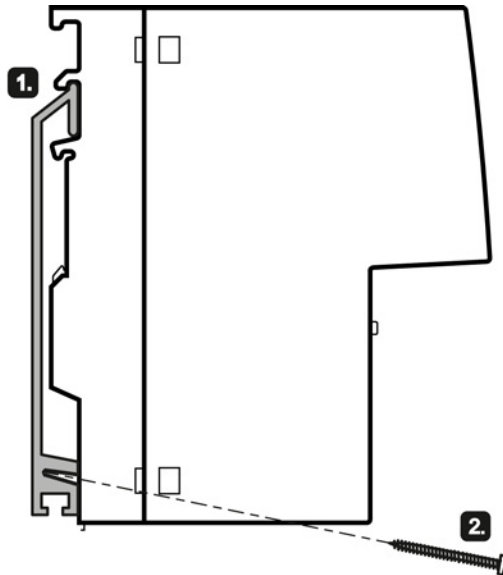

Figure 4-2 S7-300 standard rail mounting

1. Place the second housing guide of the device on the top edge of the standard rail ①.
2. Screw the device to the lower part of the standard rail with the supplied screw ②.

Removal

To remove the device from a standard rail, follow the steps below:

1. Release the screw on the bottom of the standard rail.
2. If the extender is connected to a basic device, disconnect the extender, see section "Fitting an extender (Page 29)".
3. Remove the device from the standard rail.

4.5 Installation on a standard S7-1500 rail

Installing on an S7-1500 standard rail

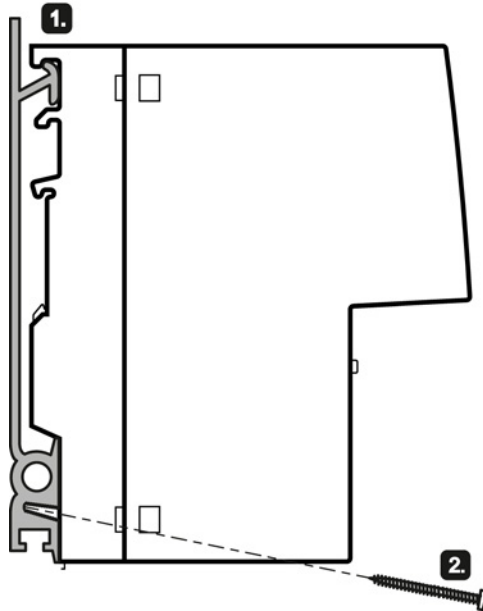

Figure 4-3 S7-1500 standard rail mounting

To install the device on an S7-1500 standard rail, follow the steps below:

1. Place the first housing guide of the device on the top edge of the standard rail ①.
2. Screw the device to the lower part of the standard rail with the supplied screw ②.

Removal

To remove the device from a standard rail, follow the steps below:

1. Release the screw on the bottom of the standard rail.
2. If the extender is connected to a basic device, disconnect the extender, see section "Fitting an extender (Page 29)".
3. Remove the device from the standard rail.

4.6 Fitting an extender

Position

The following figure shows the elements required to connect two devices.

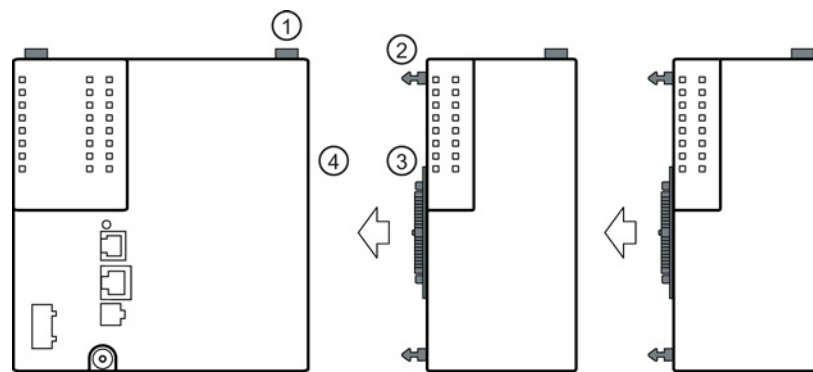

- ① Locking mechanism (on the rear of the device)
- ② Centering pin
- ③ Multipole connector for connection to the expansion interface
- ④ Expansion interface with cover

Via the expansion interface, the basic device supplies the extenders with power and manages the ports of the extenders.

The power provided by the PE408PoE port extender for Power over Ethernet does not come from the basic device. Connect an external power source.

Types of installation

You have the following options when connecting devices:

- You can connect the devices and mount them together on a DIN or S7 standard rail.
- You can mount a device on a DIN or S7 standard rail and expand it later.

Note

For mounting on a rail as well as for removing from the rail, plan enough space between the devices, see section "Dimension drawings (Page 41)".

Fitting and removing an extender

Fitting an extender

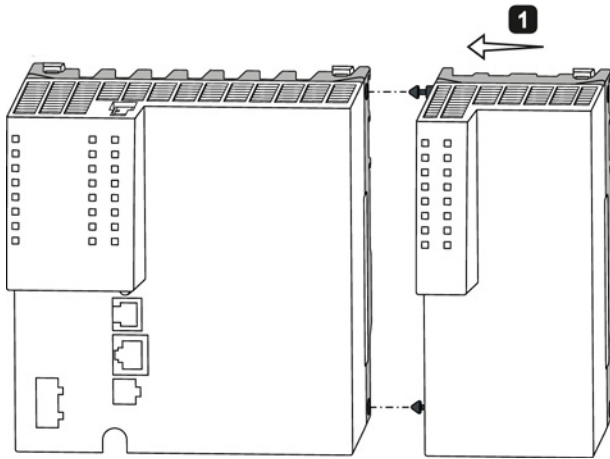

To fit an extender, follow the steps below:

1. Remove the cover of the expansion interface on the basic device.
2. Fit the two devices together so that the two centering pins are accommodated by the opposing openings ①.
3. Press the devices together until they are flush.

The centering pins click audibly into place. The locking device is automatically pressed up briefly as this happens.

Removing an extender

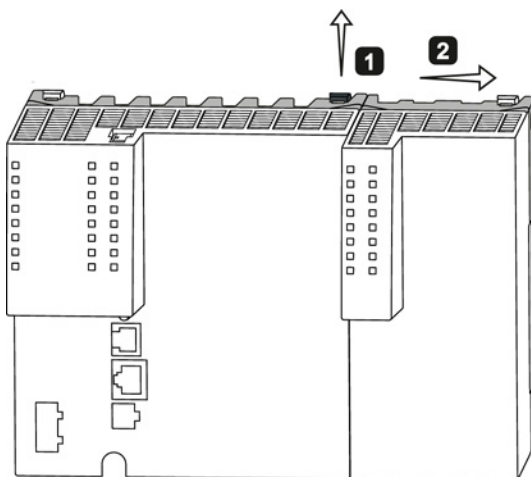

To remove an extender, follow the steps below:

1. Release the locking device using a screwdriver ①.
The two devices are separated from each other.
2. Pull the two devices apart in a straight line ② until the two centering pins are completely out of the openings.

Exchanging extenders - with change of medium

Exchanging extenders

If you replace an electrical extender with an optical extender (or vice versa), this can lead to malfunctions.

The IE switch therefore reacts as follows:

- The extender is disabled.
- The red fault LED "F" lights up.
- The event is shown in the log table in WBM.

Enabling the extender

To activate the replacement extender, restart the IE switch:

- The extender is active.
- The red fault LED "F" goes off.

Connecting up

5.1 Safety when connecting up

Safety notices

When connecting up the device, keep to the safety notices listed below.

 WARNING
<p>The equipment is designed for operation with Safety Extra-Low Voltage (SELV) by a Limited Power Source (LPS).</p> <p>This means that only SELV / LPS complying with IEC 60950-1 / EN 60950-1 / VDE 0805-1 must be connected to the power supply terminals. The power supply unit for the equipment power supply must comply with NEC Class 2, as described by the National Electrical Code (r) (ANSI / NFPA 70).</p> <p>If the equipment is connected to a redundant power supply (two separate power supplies), both must meet these requirements.</p>

Safety notices on use in hazardous areas

General safety notices relating to protection against explosion

 WARNING
<p>EXPLOSION HAZARD</p> <p>DO NOT CONNECT OR DISCONNECT EQUIPMENT WHEN A FLAMMABLE OR COMBUSTIBLE ATMOSPHERE IS PRESENT.</p>

Safety notices when using the device according to Hazardous Locations (HazLoc)

If you use the device under HazLoc conditions you must also keep to the following safety notices in addition to the general safety notices for protection against explosion:

 WARNING
<p>EXPLOSION HAZARD</p> <p>DO NOT DISCONNECT WHILE CIRCUIT IS LIVE UNLESS AREA IS KNOWN TO BE NON-HAZARDOUS.</p>

Safety notices when using the device according to ATEX

If you use the device under ATEX conditions you must also keep to the following safety notices in addition to the general safety notices for protection against explosion:

 **WARNING**

Take measures to prevent transient voltage surges of more than 40% of the rated voltage. This is the case if you only operate devices with SELV (safety extra-low voltage).

5.2 PoE power supply of the PE408PoE

Notes on the PoE power supply

 **WARNING**

Incorrect power supply

The power of all connected power supply units must total the equivalent of a power source with limited power (LPS limited power source).

If the device is connected to a redundant power supply (two separate power supplies), both must meet these requirements.

Never operate the device with AC voltage or DC voltage higher than 60 V DC.

Information on the PoE power supply

- You can connect a different PoE power source to each of the two connectors. This means that devices capable of PoE can be supplied with power via the ports, see section "Power over Ethernet (PoE) (Page 20)".
- The power supply is connected using two 2-pin plug-in terminal blocks (spring-loaded terminal). The terminal blocks ship with the device.
- For the PE408PoE to be able to supply a powered device, the connected PoE power supply must provide a voltage of 54 V.
- The terminal block L1+/M1 provides the PoE power supply of ports P1 to P4. The terminal block L2+/M2 provides the PoE power supply of ports P5 to P8.
- To wire up the power connector, use a copper cable of category 18-12 AWG or cable with a cross-section of 0.75 to 2.5 mm².
- The cable for connecting the power source to the connectors L1+/M1 or L2+/M2 can be a maximum of 3 m long.

Position and assignment

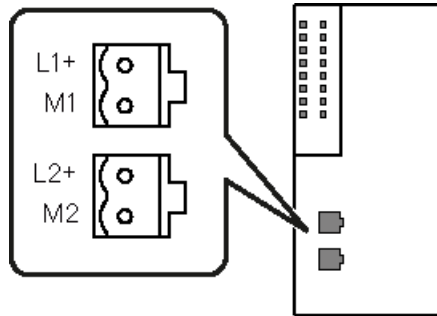

Figure 5-1 Position of the PoE power supply on the PE408PoE and the assignment of the terminal blocks

Contact	Assignment
L1+	L1+ 54 VDC
M1	Ground
L2+	L2+ 54 VDC
M2	Ground

Technical specifications

6.1 PE408

The following technical specifications apply to the port extender PE408.

Technical specifications		
Attachment to Industrial Ethernet		
Electrical connectors	Quantity	8
	Connector	RJ-45 jack
	Transmission speed	10 / 100 / 1000 Mbps
Electrical data (supply from basic device)		
Current consumption	at 24 V DC	200 mA
Effective power loss	at 24 V DC	4.8 W
Permitted ambient conditions		
Ambient temperature	During operation up to 2000 m	-40 °C to +70 °C
	During operation up to 3000 m	-40 °C to +65 °C
	During storage	-40 °C to +85 °C
	During transportation	-40 °C to +85 °C
Relative humidity	During operation at 25 °C	≤ 95 %, no condensation
Design, dimensions and weight		
Degree of protection	IP20	
Weight	600 g	
Dimensions (W x H x D)	70 x 150 x 125 mm	
Installation options	<ul style="list-style-type: none"> • Installation on a DIN rail • Installation on an S7-300 standard rail • Installation on an S7-1500 standard rail 	
Mean time between failure (MTBF)		
	at 40 °C ambient temperature	58 years

6.2 PE408PoE

The following technical specifications apply to the port extender PE408PoE:

Technical specifications		
Attachment to Industrial Ethernet		
Electrical connectors	Quantity	8
	Connector	RJ-45 jack
	Transmission speed	10 / 100 / 1000 Mbps
Electrical data (supply from basic device)		
Current consumption	at 24 V DC	200 mA
Effective power loss	at 24 V DC	4.8 W
Electrical specifications of the PoE power supply		
Supply connector	Quantity	2
Power supply per connector	Rated voltage	54 VDC
	Voltage range	51.3 V DC - 56.7 V DC
	Design	Terminal block, 2 terminals
	Cable cross-section	
		<ul style="list-style-type: none"> • Minimum • Maximum
	Property	Not implemented redundantly
Fuse per connector		4 A / 125 V
Current consumption per connector	at 54 V DC	1.75 A
Effective power loss per connector	at 54 V DC	4.5 W
PoE power per connector	at 54 V DC	90 W
Permitted ambient conditions		
Ambient temperature	During operation up to 2000 m	-40 °C to +60 °C
	During operation up to 3000 m	-40 °C to +55 °C
	During storage	-40 °C to +85 °C
	During transportation	-40 °C to +85 °C
Relative humidity	During operation at 25 °C	≤ 95 %, no condensation
Design, dimensions and weight		
Degree of protection	IP20	
Weight	650 g	
Dimensions (W x H x D)	70 x 150 x 125 mm	
Installation options	<ul style="list-style-type: none"> • Installation on a DIN rail • Installation on an S7-300 standard rail • Installation on an S7-1500 standard rail 	
Mean time between failure (MTBF)		
	at 40 °C ambient temperature	33 years

6.3 PE400-8SFP

The following technical specifications apply to the port extender PE400-8SFP.

Technical specifications			
Attachment to Industrial Ethernet			
Slots for SFP transceivers	Quantity	8	
	Connector	SFP transceivers (LC port)	
	Transmission speed	100 / 1000 Mbps	
Electrical data (supply from basic device)			
Current consumption	at 24 V DC	without SFP transceiver	70 mA
		depending on the SFP transceiver	max. 210 mA
Effective power loss	at 24 V DC	without SFP transceiver	1.7 W
		depending on the SFP transceiver *)	max. 5 W
Permitted ambient conditions			
Ambient temperature	During operation up to 2000 m	-40 °C to +60 °C	
	During operation up to 3000 m	-40 °C to +55 °C	
	During storage	-40 °C to +85 °C	
	During transportation	-40 °C to +85 °C	
Relative humidity	During operation at 25 °C	≤ 95 %, no condensation	
Design, dimensions and weight			
Degree of protection	IP20		
Weight	600 g		
Dimensions (W x H x D)	70 x 150 x 125 mm		
Installation options	<ul style="list-style-type: none"> • Installation on a DIN rail • Installation on an S7-300 standard rail • Installation on an S7-1500 standard rail 		
Mean time between failure (MTBF)			
	at 40 °C ambient temperature	63 years	

*) You will find the precise values in the operating instructions of the SFP transceivers.

You will find the operating instructions of the SFP transceivers:

- on the data medium that ships with some products:
 - Product CD / product DVD
 - SIMATIC NET Manual Collection
- on the Internet pages of Siemens Industry Online Support under the following entry ID: 67701566 (<http://support.automation.siemens.com/WW/view/en/67701566>)

Dimension drawings

Note

Dimensions are specified in mm.

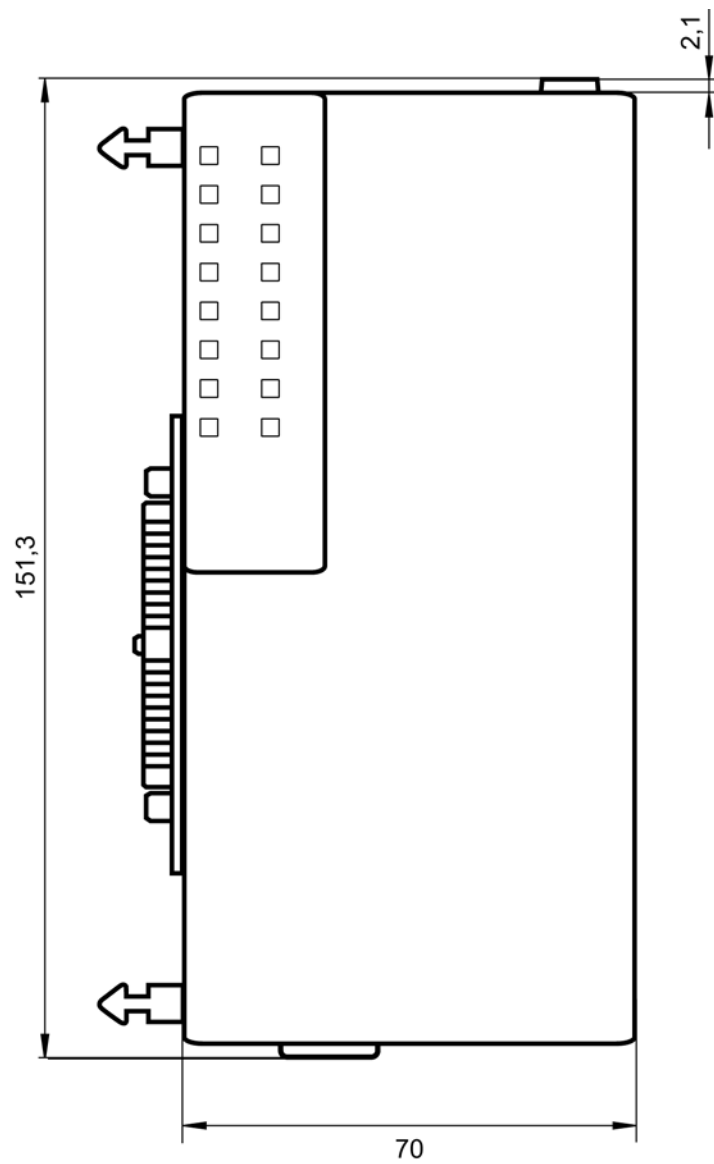
Front view

Side view

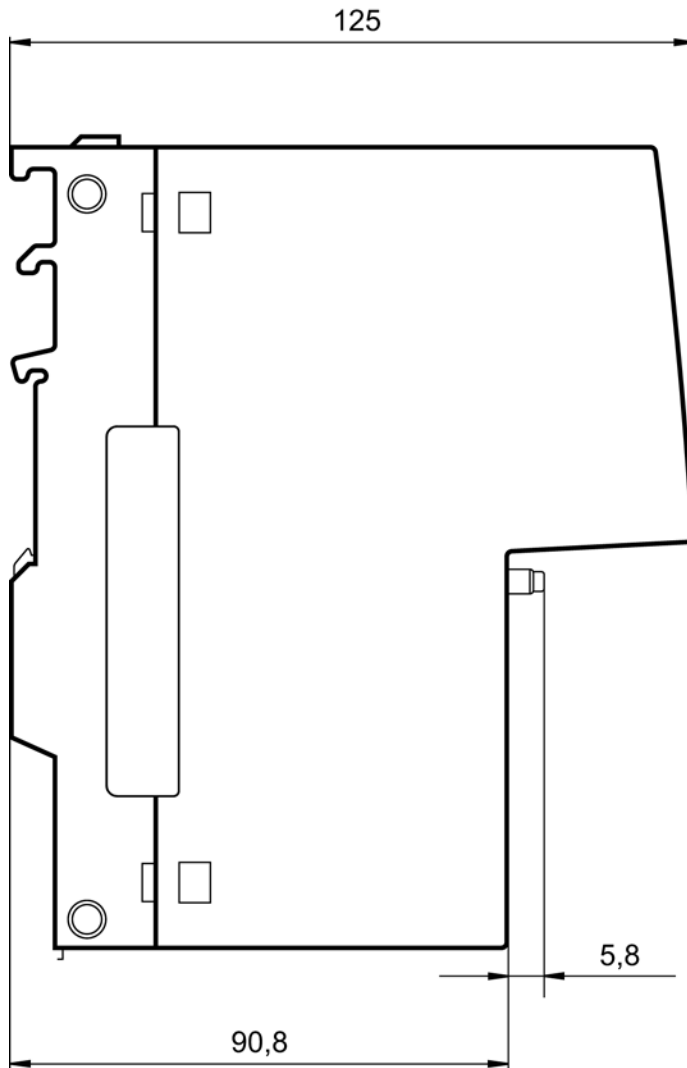

From above

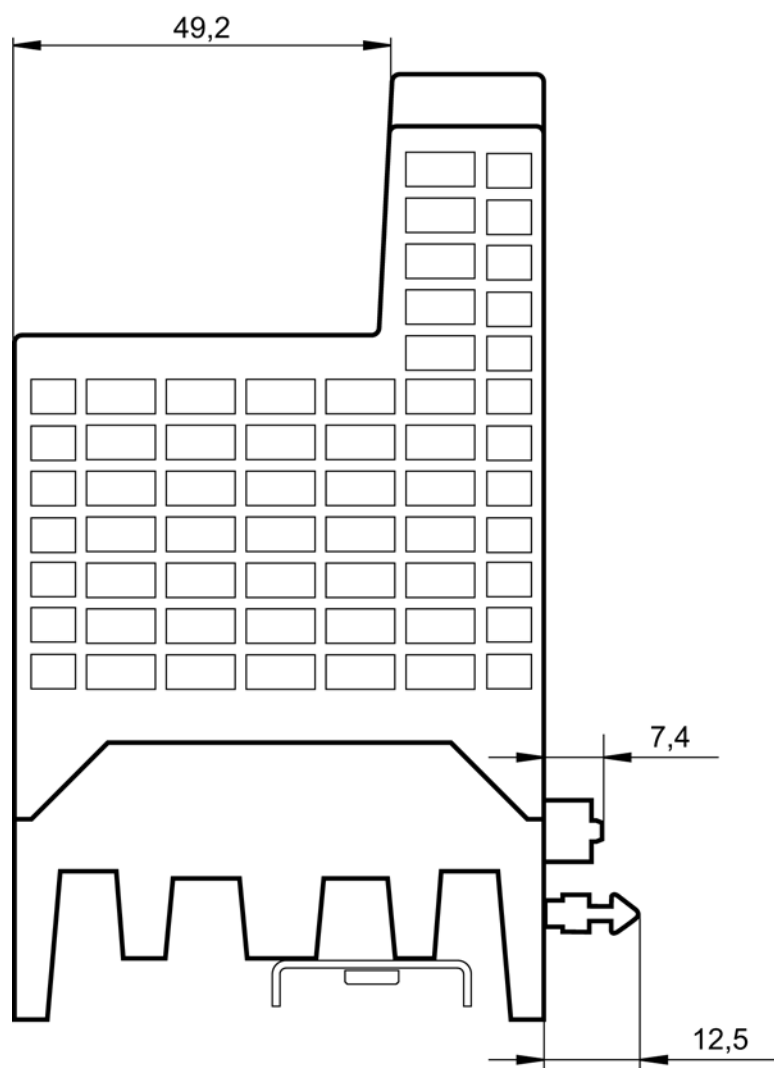

Approvals

The SIMATIC NET products described in these Operating Instructions have the approvals listed below.

Note

Issued approvals on the type plate of the device

The specified approvals apply only when the corresponding mark is printed on the product. You can check which of the following approvals have been granted for your product by the markings on the type plate.

EC directives

SIMATIC NET products meet the requirements and aims of the following EC directives.

EMC directive (electromagnetic compatibility)

The SIMATIC NET products described in these operating instructions meet the requirements of EC directive 2004/108/EC "Electromagnetic Compatibility" for the following areas of application:

Field of application	Requirements	
	Emission	Immunity to interference
Industry	EN 61000-6-4 : 2007	EN 61000-6-2 : 2005

<p> WARNING</p> <p>Personal injury and property damage can occur</p> <p>The installation of expansions that are not approved for SIMATIC NET products or their target systems may violate the requirements and regulations for safety and electromagnetic compatibility.</p> <p>Only use expansions that are approved for the system.</p>

- **Keep to the installation guidelines**
The devices meet the requirements if you adhere to the installation and safety instructions contained in this documentation and in the following documentation when installing and operating the devices.
- **You can always find the latest documentation on the Internet**
The current descriptions of the currently available products can always be found on the Internet under the specified entry IDs/Internet pages:
 - "Industrial Ethernet / PROFINET Industrial Ethernet" System Manual
 - "Industrial Ethernet / PROFINET - Passive network components" System Manual
You will find information on the system manuals in the section "Introduction (Page 5)", in "Further documentation".
 - "EMC Installation Guidelines" configuration manual
ID = 60612658 (<http://support.automation.siemens.com/WW/view/en/60612658>)
- **Working on the device**
To protect the device from electrostatic discharge, personnel must first discharge any electrostatic charge from their body before touching the device.

Note

The test was performed with a device and a connected communications partner that also meets the requirements of the standards listed above.

When operating the device with a communications partner that does not comply with these standards, adherence to the corresponding values cannot be guaranteed.

Safety of electrical equipment

In the version put into circulation by Siemens AG, the SIMATIC NET products described in these Operating Instructions conform to the regulations of the following European directive:

- EN 60950-1
Information technology equipment - Safety - Part 1: General requirements

ATEX (explosion protection directive)

 WARNING
<p>When using SIMATIC NET products in hazardous area zone 2, make absolutely sure that the associated conditions in the following document are adhered to:</p> <p>"SIMATIC NET Product Information Use of subassemblies/modules in a Zone 2 Hazardous Area".</p> <p>You will find this document</p> <ul style="list-style-type: none"> • on the data medium that ships with some devices. • on the Internet pages of Siemens Industry Online Support (http://support.automation.siemens.com/WW/view/en). <p>Enter the document identification number C234 as the search term.</p>

SIMATIC NET products meet the requirements of the EC directive:94/9/EC "Equipment and Protective Devices for Use in Potentially Explosive Atmospheres".

ATEX classification:

II 3 G Ex nA IIC T4 Gc

KEMA 07ATEX0145 X

The products meet the requirements of the following standards:

- EN 60079-15: 2010 (electrical apparatus for potentially explosive atmospheres; Type of protection "n")
- EN 60079-0: 2009 (Explosive atmospheres - Part 0: Equipment - General requirements)

FM

The product meets the requirements of the standards:

- Factory Mutual Approval Standard Class Number 3611
- FM Hazardous (Classified) Location Electrical Equipment:
Non Incendive / Class I / Division 2 / Groups A,B,C,D / T4 and
Non Incendive / Class I / Zone 2 / Group IIC / T4

C-TICK

The product meets the requirements of the AS/NZS 2064 standard (Class A).

cULus Approval for Information Technology Equipment

cULus Listed I. T. E.

Underwriters Laboratories Inc. complying with

- UL 60950-1 (Information Technology Equipment)
- CSA C22.2 No. 60950-1-03

Report no. E115352

cULus Approval Hazardous Location

cULus Listed I. T. E. FOR HAZ. LOC.

Underwriters Laboratories Inc. complying with

- UL 60950-1 (Information Technology Equipment)
- ANSI/ISA 12.12.01-2007
- CSA C22.2 No. 213-M1987

Approved for use in

Cl. 1, Div. 2, GP A, B, C, D T4

Cl. 1, Zone 2, GP IIC T4

Report no. E240480

FDA and IEC marks

The following devices meet the FDA and IEC requirements listed below:

Device	Fulfills FDA and IEC requirements
PE408	-
PE408PoE	-
PE400-8SFP	•
With modular devices, the marking is on the extenders and pluggable transceivers.	



Figure A-1 FDA and IEC approvals

Index

A

Accessories, 13

B

Basic device, 11

C

Centering pin, 14, 29

Components of the product, 13

E

Expansion, 11

Expansion interface, 11, 29

Extender, 11

G

Glossary, 7

L

LED display, 14

Locking mechanism, 29

O

Order numbers, 12

P

PE408PoE, 29

Pluggable transceiver, 13

PoE, 20, 29, 34

Port extender PE408PoE, 29

Port extender, 12

Port extender PE408PoE, 29

Power over Ethernet, 20, 29, 34

Port extender PE408PoE, 29

Power supply, 34

S

Safety notices

for installation, 23

general, 9

Use in hazardous areas, 9, 23, 33

when connecting up, 33

SFP transceiver slots, 11

SIMATIC NET glossary, 7

SIMATIC NET manual, 7

System manual, 6, 46

